

SHORT WAVE CRAFT

Edited by
HUGO GERNSBACK



May
32

IN THIS ISSUE

- 5-METER RECEIVERS,
BY A. BINNEWEG, JR.
- CRYSTAL DETECTOR—BAND PASS—
SUPER-HET, BY R. WM. TANNER
- "DEAD SPOTS"—THEIR CAUSE
AND CURE!
- DO "RADIO ECHOES" COME FROM
SPACE?

NOW
25¢

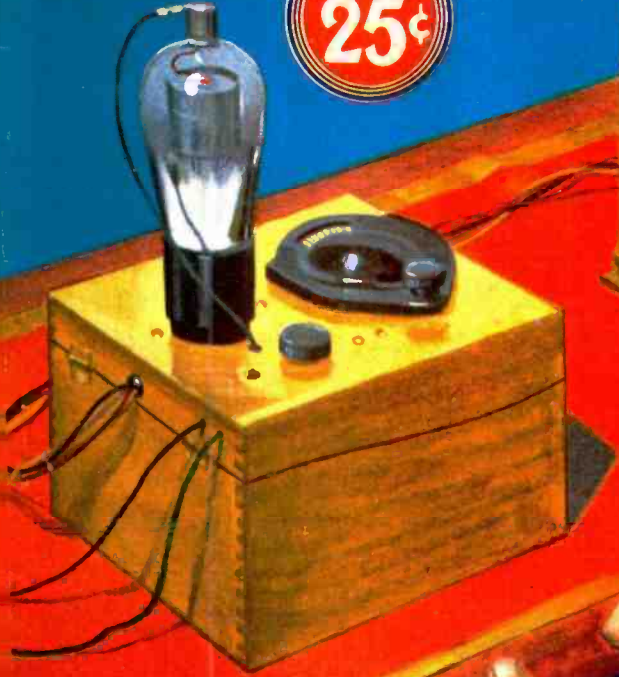

MAKE THIS
NEW
**POLICE
THRILL BOX**
See Page 14

IN THIS
ISSUE
\$500.00
SHORT WAVE
PRIZE CONTEST



9-COIL CIRCUIT
 NEW TYPE SUPER-HETERODYNE
 ONE CONTROL - 18 TO 550 METERS
 FINEST BROADCAST RECEPTION
 SUPER-SENSITIVE ON SHORT WAVES
 NEW DESIGN - NEW RESULTS

\$59⁵⁰
 COMPLETE
 WITH TUBES

THE NEW PILOT DRAGON 4-BAND SET

Just out — PILOT CATALOG!

Just out — PILOT catalog!

Everything for the service man, set builder, and experimenter is to be found in the new PILOT catalog.

REPLACEMENT PARTS. All PILOT's replacement parts are listed. They include power transformers, all types of resistors, dry electrolytic condensers, loudspeakers, chokes, and other manufacturers' type parts for Service Men.

EXPERIMENTERS' PARTS. New instruments for experimenters have been added, making PILOT's line of parts the most complete offered by any Company.

SHORT WAVE EQUIPMENT. PILOT has always been headquarters for short-wave equipment. The new catalog and a supplement now in preparation include everything for building short-wave receivers.

S.W. TYPE 224-A TUBES. The PILOT 224-A tube is especially designed to reduce noises in S. W. receivers. It will improve your results.

WRITE TODAY. Send 5c in stamps for the PILOT catalog or, better, send 50c for a year's subscription to Radio Design Quarterly and the catalog and supplement will be sent FREE. Don't delay! Do it today!



POLICE ALARMS - AIRPLANES IN FLIGHT } PLUS REGULAR
 SHIPS AT SEA - FOREIGN STATIONS } BROADCASTING

You'll put your O.K. on this set as the most beautiful piece of radio design you have ever seen. Ask your dealer to show you how the DRAGON wave-band switch changes from three coils for broadcast pre-selection to any independent pair of coils for each of the three short-wave bands. Notice how other sets using tapped coils, loaded with dead end losses, fail at high frequencies. Listen to the DRAGON's freedom from inter-band interference in contrast to results on makeshift tapped-coil circuits. Examine the precision construction of the 9-coil catacomb. Listen to the quality of the new amplifier and the acoustic cabinet. Then you'll say, "That's my idea of a Radio Set!" and you'll tell your B.C.L. friends so, too.

NO PLUG-IN COILS

This 9-coil catacomb and switch is built into the chassis of the new DRAGON all-wave receiver. This method of construction eliminates all dead-end losses.

Complete information about the DRAGON receiver will be sent to you free if you will include your radio dealer's name and address with your request.



PILOT RADIO & TUBE CORP.

(Short Wave Headquarters - Established 1908)

FACTORIES - LAWRENCE, MASSACHUSETTS

BEAT PAY CUTS



"You bet I can fix it but I have 3 jobs ahead of yours. I'll be over in an hour!"



WORK FOR YOURSELF

If they've cut your pay—go to work for yourself! Put in as many hours as you like. Set your own prices. Name your own pay. Be independent! You can, if you're an R. T. A. Certified Radiotechnician engaged in the highly profitable business of servicing all kinds of radio sets and equipment. Here is a field that actually *needs* trained men, and R. T. A. has made it possible for you to break in and make money almost at the very start.

A Wonderful, Practical Plan

The Radio Training Association of America is not just a school that merely gives you a certain amount of radio fact, then leaves you to shift for yourself. Indeed not. You really become a lifetime member of the great R. T. A., and with your course you get the fine R. T. A. Set Analyzer and Trouble Shooter illustrated here. With this equipment and your R. T. A. training you'll be able to locate the trouble in any set, *quickly*, and get a good big price for the few minutes needed for the repair. That's what makes the R. T. A. plan so practical; you begin making real money almost immediately after joining. As a member of R. T. A. you should be the most popular radio service man in town—your income limited mainly by your willingness to work. Up to \$20 a day is easy.

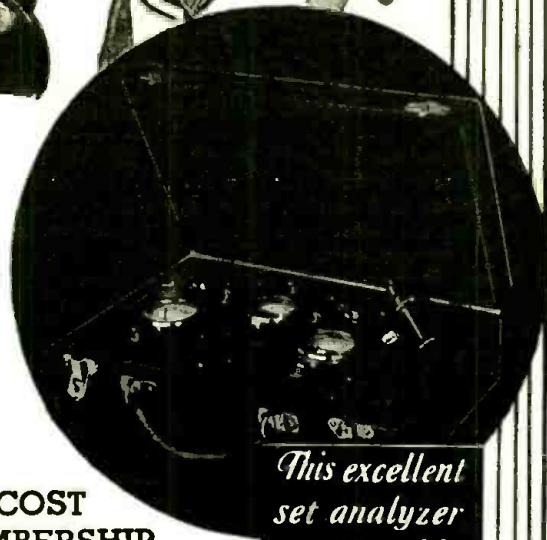

This excellent set analyzer and trouble shooter included with our course of training

NO-COST MEMBERSHIP PLAN

We have worked out a truly wonderful plan whereby R. T. A. membership, the R. T. A. Course, and the R. T. A. Set Analyzer and Trouble Shooter need not cost you a cent. The coupon will bring you full particulars. Clip—fill in—mail now! Today!

RADIO TRAINING ASSOCIATION OF AMERICA
4513 Ravenswood Ave., Dept SW6, Chicago
Send me full particulars of your No-Cost Membership Plan.

Name.....

Street.....

Town..... State.....

RADIO TRAINING ASSOCIATION OF AMERICA
4513 Ravenswood Avenue Dept. SWC6 Chicago, Illinois

HUGO GERNSBACK, Editor

H. WINFIELD SECOR, Managing Editor

CONTENTS

MAY, 1932

*In This Issue: Prominent Short Wave Authors***Neuburger – Nentwig – Denton – Noack – Hertzberg – Binneweg – Messing – Tanner****FEATURES:**

Editorial—The Short Wave Telephone, by Hugo Gernsback	7
Short Waves in the Public Eye.....	8
Honolulu To New York on Short Waves.....	9
Heinrich Hertz, by Dr. Albert Neuburger, Ph.D. (Berlin)	10
\$500.00 in Prizes to Set-Builders, by Hugo Gernsback	11
Simple Transmitters and Receivers for Ultra Short Waves, by Kurt Nentwig.....	12
A Police Short Wave "Thrill-Box" That Works! by H. Gernsback and Clifford E. Denton.....	14
At Last! Oliver Amlie's "DX" Hook-up.....	17
Announcing the SHORT WAVE LEAGUE, by Hugo Gernsback	18
A 5 Meter Transmitter, by George Herrscher, W2APW, and E. P. Hufnagle, W2BUK.....	20
Radio Ghost, by Dr. F. Wolf.....	22
How "Te-Ka-De" .1 Inch Wave Transmitter and Receiver Bridged Two-thirds Mile, by Dr. Fritz Noack	24
Experiments With Ultra Short Waves, by Robert Kratzenstein	26
5 Meters and Below, by R. Rapcke.....	28
A Crystal Detector, Band Pass, Super-Het For Short Waves, R. W. Tanner.....	34
Dead Spots—Their Cause and Cure, by Edgar Messing	39

SHORT WAVES FOR THE BROADCAST LISTENER:

\$500.00 Prize Contest For Set-Builders.....	11
Police S-W "Thrill-Box".....	14
At Last! Oliver Amlie's "DX" Receiver Hook-up..	17
Simple Vertical S-W Aerials That Bring In Stronger Signals With Less Fading.....	23
The Blanchard Short Wave Converter.....	25
The Baird S-W Converter.....	30
The New Pilot "Dragon" All-Wave Receiver, by M. B. Sleeper.....	36
Short Wave Stations of the World—"Call Letters" and "Wave-Lengths".....	42

SHORT WAVE RECEIVERS:

Receivers for Ultra Short Waves, by Kurt Nentwig	12
Police Call Short Wave Converter.....	14
Oliver Amlie's "DX" Receiver Circuit, 12 to 900 Meter Range	17
More About the "Midwest" Converter.....	23
A .4 inch Wave Receiver.....	24
The Blanchard S-W Converter.....	25
5 Meter Receiver, by R. Rapcke.....	28
The Baird Short Wave Converter—including coil data	30
You Can Enjoy Real Comfort With This Receiver Layout, by Robert "Bob" Hertzberg, W2DJJ..	31
5 Meter Receivers, by A. Binneweg, Jr.....	32
A Crystal Detector, Band Pass, Super-Heterodyne, by R. W. Tanner.....	34
The New Pilot "Dragon" All-wave Receiver.....	36
Dead Spots—Their Cause and Cure.....	39

SHORT WAVE TRANSMITTERS:

Ultra Short Wave Transmitters.....	12
A 5 Meter Transmitter, by George Herrscher, W2APW, and E. P. Hufnagle, W2BUK.....	20
.4 inch Wave Transmitter, by Dr. Fritz Noack... ..	24
Ultra Short Wave Transmitters, by Robert Kratzenstein	26
Transmitters for Use Below 5 Meters.....	28
A Stable Small Transmitter, by Woltmann.....	38
160 Meter Antenna Design.....	45

MISCELLANEOUS:

\$500.00 Prizes to Set-Builders.....	11
Police "Thrill-Box" Converter—How to Build it..	14
Announcing The SHORT WAVE LEAGUE.....	18
Short Wave Hints.....	33
A Novel Filter for Short Wave Receivers, by Henri F. Dalpayrat	38
Letters From S-W Fans.....	40
Short Wave Stations Of The World—"Call Letters" and "Wave-Lengths"	42
Police Call Wave-Lengths.....	44
The Superregenerate With The New 6 Volt Tubes, by Clifford E. Denton.....	41
Short Wave Question Box, Edited by R. W. Tanner "When To Listen In"—by Robert Hertzberg.....	61

OUR COVER — Real thrills are brought into your home by listening to police calls with the short wave converter described by Hugo Gernsback and Clifford E. Denton on page... 14

SHORT WAVE CRAFT—Monthly. Entered as second class matter May 7, 1930, at the post office at Mount Morris, Illinois, under the act of March 3, 1879. Trademarks and copyrights by permission of H. Gernsback, 93 Park Place, N. Y. C. Text and illustrations of this magazine are copyright and must not be reproduced without permission. SHORT WAVE CRAFT is published on the 15th of every month. Twelve numbers per year. Subscription price is \$1.50 a year in the United States and possessions. Canada and foreign countries, \$1.75

London Agent:

HACHETTE & CIE.,
16-17 King William St.,
Charing Cross, W.C.2

Paris Agent:

HACHETTE & CIE.,
111 Rue Reaumur

COPYRIGHT, 1932, BY H. GERNSBACK

Published by **POPULAR BOOK CORPORATION**

HUGO GERNSBACK, President - H. W. SECOR, Vice-President
EMIL GROSSMAN - Director of Advertising
Chicago Adv. Office - L. F. McCLURE, 737 No. Michigan Blvd.

Publication Office, 404 N. Wesley Avenue, Mount Morris, Ill.
Editorial and General Offices, 96-98 Park Place, New York, N. Y.

Australian Agents:
McGILL'S AGENCY,
179 Elizabeth St.,
Melbourne

OPPORTUNITIES *are many* for the Radio Trained Man

Don't spend your life slaving away in some dull, hopeless job! Don't be satisfied to work for a mere \$20 or \$30 a week. Let me show you how to get your start in Radio—the fastest-growing, biggest money-making game on earth.

Jobs Leading to Salaries of \$50 a Week and Up
Prepare for jobs as Designer, Inspector and Tester—as Radio Salesman and in Service and Installation Work—as Operator or Manager of a Broadcasting Station—as Wireless Operator on a Ship or Airplane, or in Talking Picture or Sound Work—HUNDREDS of OPPORTUNITIES for a real future in Radio!

Ten Weeks of Shop Training

We don't teach by book study. We train you on a great outlay of Radio, Television and Sound equipment—on scores of modern Radio Receivers, huge Broadcasting equipment, the very latest and newest Television apparatus, Talking Picture and Sound Reproduction equipment, Code Practice equipment, etc. You don't need advanced education or previous experience. We give you—RIGHT HERE IN THE COYNE SHOPS—the actual practice and experience you'll need for your start in this great field. And because we cut out all useless theory and only give that which is necessary you get a practical training in 10 weeks.



TELEVISION *and* TALKING PICTURES

And Television is already here! Soon there'll be a demand for THOUSANDS of TELEVISION EXPERTS! The man who learns Television now can have a great future in this great new field. Get in on the ground-floor of this amazing new Radio development! Come to COYNE and learn Television on the very latest, new-

est Television equipment. Talking Picture and Public Address Systems offer opportunities to the Trained Radio Man. Here is a great new Radio field just beginning to grow! Prepare NOW for these wonderful opportunities! Learn Radio Sound Work at COYNE on actual Talking Picture and Sound Reproduction equipment.



All Practical Work At COYNE In Chicago

ALL ACTUAL, PRACTICAL WORK. You build radio sets, install and service them. You actually operate great Broadcasting equipment. You construct Television Receiving Sets and actually transmit your own Television programs over our modern Television equipment. You work on real Talking Picture machines and Sound equipment. You learn Wireless Operating on actual Code Practice apparatus. We don't waste time on useless theory. We give you the practical training you'll need—in 10 short, pleasant weeks.

Many Earn While Learning

You get Free Employment Service for Life. And don't let lack of money stop you. Many of our students make all or a good part of their living expenses while going to school and if you should need this help just write to me. Coyne is 32 years old! Coyne Training is tested—proven beyond all doubt. You can find out everything absolutely free. Just mail coupon for my big free book!

H. C. Lewis, Pres. RADIO DIVISION Founded 1899
COYNE Electrical School
500 S. Paulina St., Dept. 52-4K, Chicago, Ill.

Mail Coupon Today for All the Facts

H. C. LEWIS, President
Radio Division, Coyne Electrical School
500 S. Paulina St., Dept. 52-4K, Chicago, Ill.

Dear Mr. Lewis:— Send me your Big Free Radio Book, and all details of your Special Offer.

Name

Address

City.....State.....

ORDER DIRECT FROM THIS PAGE

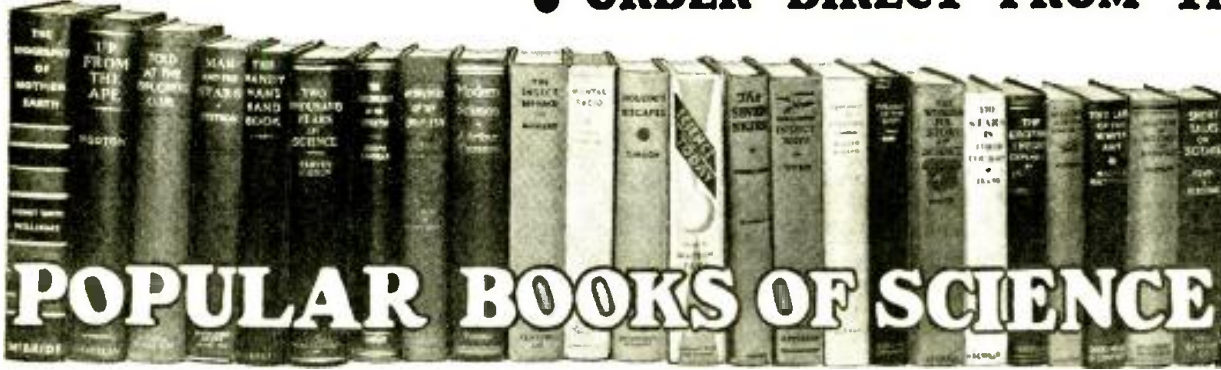

POPULAR BOOKS OF SCIENCE

WE herewith present the most complete collection of recent important popular Science books. We have, after an exhaustive study, selected these volumes because they represent the foremost books of their kind in print today. There is such a great variety that we are sure it will satisfy any taste as well as any requirement of the student of science. We publish no catalogue and ask you to be kind enough to order direct from this page. Prompt shipments will be made to you direct from the publishers. We merely act as a clearing house for a number of publishers and OUR PRICES ARE AS LOW OR LOWER THAN WILL BE FOUND ANYWHERE. Remit by money order or certified check. If you send cash, be sure to register it.

ASTRONOMY
MAN AND THE STARS, by Harlan T. Sisson. Cloth covers, size 5 1/2 x 8 1/2, 221 pages, illustrated. Price \$2.50

DREAMS OF AN ASTRONOMER, by Camille Flammarion. Cloth covers, size 5 1/2 x 8 1/2, 223 pages. Price \$2.50

THE UNIVERSE AROUND US, by Sir James Jeans. Cloth covers, size 5 1/2 x 8 1/2, 351 pages, 24 illustrations. Price \$4.50

SIGNALS FROM THE STARS, George Ellery Hale. Cloth covers, size 5 x 8, 138 pages, 56 illustrations. Price \$2.00

THE STARS IN THEIR COURSES, by Sir James Jeans. Cloth covers, size 6 x 8 1/2, 172 pages, 50 illustrations and maps. Price \$2.50

POPULAR ASTRONOMY, by Camille Flammarion. Cloth covers, size 6 1/4 x 9 1/4, 696 pages, 291 illustrations. Price \$6.00

WINGS OF TOMORROW, by de la Cierva. Cloth covers, size 8 1/2 x 5 1/2, 284 pages, 31 illustrations. Price \$2.50

OPPORTUNITIES IN AVIATION, by Walter Hinton. Cloth covers, size 5 1/2 x 8 1/2, 255 pages, 11 illustrations, map and charts. Price \$3.00

AVIATION AND ALL ABOUT IT, by A. Frederick Collins. Cloth covers, size 5 1/2 x 8 1/2, 260 pages, 134 illustrations. Price \$2.00

CHEMISTRY
THE AMATEUR CHEMIST, by A. Frederick Collins. Cloth covers, size 5 x 8 1/2, 210 pages, 77 illustrations. Price \$1.50

EXPERIMENTAL CHEMISTRY, by A. Fred Collins. Cloth covers, size 5 1/2 x 7 1/2, 276 pages, 108 illustrations. Price \$2.00

THE MAKING OF CHEMISTRY, by Benjamin Harrow. Cloth covers, size 5 1/2 x 7 1/2. Price \$2.00

EXPLORATION
TOLD AT THE EXPLORERS CLUB, by Vilhjalmur Stefansson, Sir Hubert Wilkins, Col. Chas. A. Lindbergh, Capt. Felix Riisenbergh, Dr. Roy Chapman Andrews and others. Edited by Frederick A. Blossom, Ph.D. Cloth cover, size 6 x 9, 425 pages, 34 illustrations. Price \$3.50

GENERAL SCIENCE
TWO THOUSAND YEARS OF SCIENCE, by R. J. Harvey-Gibson. Cloth covers, size 5 1/2 x 8 1/2, 522 pages, fully illustrated. Price \$3.50

UP FROM THE APE, by Earnest A. Hooton. Cloth covers, size 5 1/2 x 9 1/2, 805 pages, 86 illustrations. Price \$5.00

EVOLUTION, by Vernon Kellogg. Cloth covers, size 5 1/2 x 8 1/2, 291 pages. Price \$1.75

EXPERIMENTAL SCIENCE, by A. Frederick Collins. Cloth covers, size 5 1/2 x 8 1/2, 280 pages, 152 illustrations. Price \$2.00

SCIENCE TODAY, by Watson Davis. Cloth cover, size 5 1/2 x 8 1/2, 310 pages. Price \$2.50

SHORT TALKS ON SCIENCE, by Edwin E. Sisson. Cloth covers, size 5 x 7 1/2, 281 pages, 20 illustrations. Price \$2.00

WONDERFUL STORY OF SCIENCE, by I. McFee. Cloth covers, size 5 1/2 x 8, 400 pages, 125 illustrations. Price \$2.50

MASTERS OF SCIENCE AND INVENTION, by Floyd Darrow. Cloth covers, size 5 x 8, 352 pages, 118 illustrations. Price \$2.25

HEALTH
HOW TO LIVE LONGER, by Robt. B. Ludy, M.D., and John C. Frank. Cloth covers, size 5 x 7 1/2, 146 pages, 40 illustrations. Price \$1.50

INVENTION
THE PSYCHOLOGY OF THE INVENTOR, by Joseph Rossman, Ph.D. Cloth covers, size 5 1/2 x 8 1/2, 252 pages, 13 illustrations. Price \$3.00

MECHANICS
EXPERIMENTAL MECHANICS, by A. Frederick Collins. Cloth covers, size 5 1/2 x 8, 302 pages, 167 illustrations. Price \$2.00

THE HANDY MAN'S BOOK, by C. T. Schaefer, M.E. Cloth covers, size 6 x 9 1/2, 341 pages, 14 illustrations and diagrams. Price \$4.00

THIS MECHANICAL WORLD, by Morton Mott-Smith, Ph.D. Cloth covers, size 5 1/2 x 7 1/2, 233 pages, 45 illustrations. Price \$2.00

THE NATURE OF THE PHYSICAL WORLD, by A. S. Eddington. Cloth covers, size 5 1/2 x 8, 353 pages, charts. Price \$3.75

THE MYSTERIOUS UNIVERSE, by Sir James Jeans. Cloth covers, size 5 1/2 x 9, 190 pages, 2 plates. Price \$1.00

MICROSCOPY AND PHOTOGRAPHY
SCIENCE AND PRACTICE OF PHOTOGRAPHY, by John R. Roebuck. Cloth covers, size 5 1/2 x 8 1/2, 298 pages, 52 illustrations. Price \$2.50

THE BOOK OF THE MICROSCOPE, by A. Frederick Collins. Cloth covers, size 5 x 7 1/2, 245 pages, 71 illustrations. Price \$1.50

MISCELLANEOUS
HOUDINI'S ESCAPES, by Walter Gibson. Cloth covers, size 6 x 8, 315 pages. Price \$2.00

THE AQUARIUM BOOK, by Rouzenger. Cloth covers, size 5 1/2 x 8 1/2, 208 pages, 57 illustrations. Price \$3.50

MOTION PICTURES
THE TALKIES, by Arthur Edwin Krows. Cloth covers, size 5 x 7 1/2, numerous illustrations, 245 pages. Price \$2.00

THE ART OF SOUND PICTURES, by W. Pitkin and W. Marston. Cloth covers, size 5 1/2 x 8, 287 pages, 15 illustrations. Price \$2.50

PHYSICS
FOUNDATIONS OF THE UNIVERSE, by M. Luckiesh. Cloth covers, size 5 1/2 x 8 1/2, 253 pages, diagrams and tables. Price \$3.00

THE NATURE OF THE PHYSICAL WORLD, by A. S. Eddington. Cloth covers, size 5 1/2 x 8, 353 pages, charts. Price \$3.75

THE EINSTEIN THEORY, by Samuel I. Guggenheimer. Cloth covers, size 5 1/2 x 7 1/2, 200 pages. Price \$2.50

THE EINSTEIN THEORY, by Samuel I. Guggenheimer. Cloth covers, size 5 1/2 x 7 1/2, 200 pages. Price \$2.50

THE UNIVERSE, by Frank Allen. Cloth covers, size 5 1/2 x 7 1/2, 145 pages, 31 illustrations. Price \$2.00

SEXOLOGY
THE SEXUAL SIDE OF MARRIAGE, by M. J. Exner, M.D. Cloth covers, size 5 x 7 1/2, 252 pages. Price \$2.50

THE BANKRUPTCY OF MARRIAGE, by V. F. Calverton. Cloth covers, size 5 1/2 x 8, 168 pages. Price \$3.00

COMPLETE BOOK OF SEX KNOWLEDGE, by Dr. Bernard Bernard. Cloth covers, size 7 1/2 x 9, 331 pages. Price \$2.75

SEX CONDUCT IN MARRIAGE, by Dr. Bernard Bernard. Cloth covers, 7 1/2 x 9, 218 pages. Price \$1.75

WOMEN, HER SEX AND LOVE LIFE, by Dr. William J. Robinson. Cloth covers, size 5 1/2 x 8 1/2, 411 pages, numerous anatomical illustrations. Price \$3.00

INSECT STORIES, by Vernon Kellogg. Cloth covers, size 5 1/2 x 7 1/2, 298 pages. Price \$2.00

LIFE OF THE WHITE ANT, by Maurice Maeterlinck. Cloth covers, size 5 1/2 x 7 1/2, 238 pages. Price \$2.50

How to order
We cannot ship C.O.D. Our prices are net, as shown. Please include sufficient postage, for Parcel Post, otherwise books must be shipped by express collect.

SCIENCE PUBLICATIONS 92 PARK PLACE NEW YORK, N. Y.

We can get ANY book in Science or Mechanics, Radio, etc. Just furnish us with Title and Author or tell us in which topic you are interested.

815 Logs of 48 foreign stations received in U.S. again Prove SCOTT ALL-WAVE the One 'Round the World Receiver

JANUARY LOGS From Scott Owners

Stations Received	Number of Logs
VK3ME	Australia.....122
VK2ME	Australia.....100
JKD	Colombia.....85
ISRO	Italy.....70
FYA	France.....69
HKA	Colombia.....50
HKA	Colombia.....49
Q5SW	England.....43
HKO	Colombia.....37
F3ICD	Indo-China.....36
PONTOISE	France.....19
ZEESEN	Germany.....15
LN	Argentina.....11
GBW	England.....10
HKE	Colombia.....10
GBU	England.....9
GBS	England.....8
HKC	Colombia.....7
FRADO	Ecuador.....6
RABAT	Morocco.....6
VRT	Bermuda.....6
CMCI	Cuba.....5
HKP	Colombia.....4
CT1AA	Portugal.....3
FTN	France.....3
KXO	Hawaii.....3
OXY	Denmark.....2
HCIDR	Ecuador.....2
JIAA	Japan.....2
PIV	Russia.....2
RV-15	Russia.....2
YRHM0	Venezuela.....2
Konzeu later	Cuba.....1
CMK	Cuba.....1
CM2MK	Cuba.....1
DIA	Germany.....1
BAH25	Spain.....1
FAQ	Spain.....1
FTK	Holland.....1
FTK	Holland.....1
KKII	Hawaii.....1
LSY	Argentina.....1
LSX-LSQ	Argentina.....1
T-14-NRH	Costa Rica.....1
Y4VV	Venezuela.....1
VW	France.....1
IZH	New Zealand.....1
2YA	New Zealand.....1

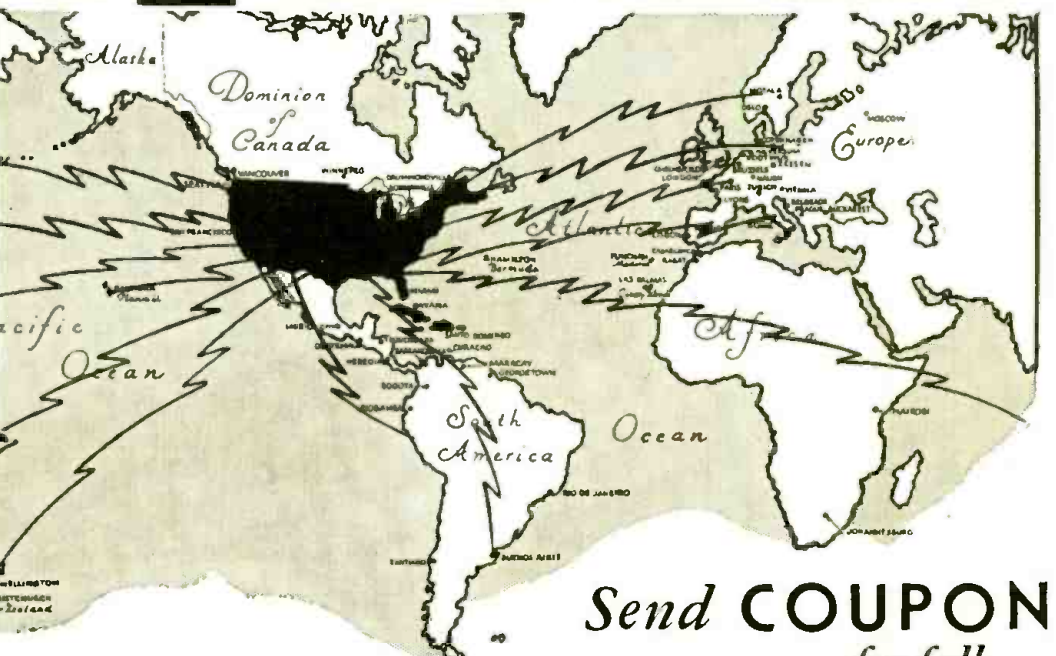

Send **COUPON** for full PARTICULARS

FROM NEW YORK AND SAN FRANCISCO—from Canada and the Gulf Coast—from everywhere in the United States—verified logs of foreign reception have poured in—815 in all—during the month of January. The most distant station was 10,500 miles away from the receiver! And most of the logs that came in were of stations over 6,000 miles distant.

These logs—this reception of foreign stations was accomplished with Scott All-Wave Receivers operating under all possible conditions. The results obtained are, therefore, AVERAGE—and represent the results YOU will get when YOU buy a Scott All-Wave for yourself. They constitute actual PROOF of the SCOTT ALL-WAVE'S ability to give daily 'round the world performance. Not just once in a while—but daily, summer and winter. And by reception, we mean loud, clear, reproduction—ample volume—clear, undistorted tone—thoroughly satisfactory in every way.

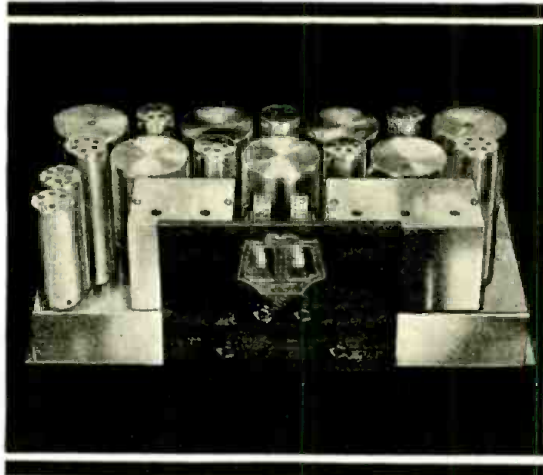

A radio that does not cover a range of 15-550 meters is completely out of date. But you want more than just a set that "dials" 15-550 meters. Even "promises" of foreign reception won't do. The set you want is the one that can PROVE its world-wide prowess BEFORE you buy it. That ONE receiver is the Scott All-Wave 15-550 Meter Superhetrodyne—a custom-built jewel of advanced design and precision engineering. The coupon will bring you full details—and you'll be happily surprised at the modest price. Clip—fill in—mail the coupon now.

The E. H. SCOTT RADIO LABORATORIES, Inc. (Formerly Scott Transformer Co.) 4450 Ravenswood Avenue Dept. C-52 Chicago, Illinois

SCOTT ALL-WAVE 15-550 METER Superhetrodyne

The E. H. Scott Radio Laboratories, Inc. 4450 Ravenswood Ave., Dept. SWC 52, Chicago, Ill.

Send me full particulars of the Scott All-Wave, 15-550 meter Superhetrodyne.

DXER SET BUILDER DEALER

Name

Street

Town State

MAY SPECIALS!!

NOTICE our important New departure in announcing Special values. Every month we will show on this page certain **STAR** items, which are **NOT LISTED IN OUR CATALOG**. These are all specials of which the quantities on hand are not sufficient to catalog them. *Once sold out, no more can be had.*

STOP SHOPPING. The lowest prices are right on this page. *No one undersells us.* We meet any price on **ANY NEW** Merchandise. Order direct from this page and save money. 100% satisfaction on every transaction. Take advantage of these special offers. **ORDER NOW, TODAY.**



NEW! "LITTLE GIANT" DYNAMIC SPEAKER

Absolutely the smallest dynamic speaker that will withstand the strain of modern output power tubes, or manufacturer's midget, portable and automobile receivers. Measures but 6 1/2 in. long over-all, having a 4 1/2 in. diaphragm and weighing but 4 lbs. The "Little Giant" has, under test, actually flooded a ten-room apartment with faithfully reproduced music of virtually original tone quality. Field winding has a resistance of 2500 ohms and may therefore be energized by using it as a filter choke in the power pack, thereby serving a double purpose. This last feature makes the "Little Giant" excellently suited for portable A.C. sets, since it does away with filter chokes and thus with considerable weight. Equipped with built-in output transformer to work from any standard output power tube arrangement. Specify the power tube or tubes used when ordering. Shipping weight 5 lbs. List Price \$6.50. No. 1549. **LITTLE GIANT DYNAMIC SPEAKER. Your Price \$2.50**

NEW! NEW! SYNCHROMATIC ELECTRIC CLOCK



Never was such a first class electric clock sold at such a ridiculously low price! An electric clock using the famous **synchromatic movement**. Naval observatory time right from your light socket! No spring to wind, no batteries. Never out of order. Lubricated for a life-time at the factory. The entire movement with its white-enamelled dial and artistic numbering is enclosed in a dust-proof and shock-proof genuine mottled Bakelite case. The case is of walnut-wood finish with simple but catching design. For 110 volts, 60 cycle A.C. operation only. Complete with cord and attachment plug. Size 3 7/8" x 1 1/2" x 1 1/2". Weight 1 lb. Service men now sell these fine clocks by the hundreds. Be the first in your locality to handle them.

List Price \$3.00.
No. 1689—Synchromatic Electric Clock. Your Price **\$1.00**

NEW RESONANCE TUNING METERS



This ingenious device INDICATES VISUALLY when a station is exactly "tuned-in-on-the-dot." Receiver is tuned to its most critical resonance point for any given station when needle swings to farthest position. Servicemen profit by installing these meters in sets which are not so equipped. Have only scales and pointers visible through an escutcheon plate. Used in new Strouberg-Carlson sets.

EXCELLENT TUNING DEVICE FOR SHORT-WAVE RECEIVERS. The extremely sharp tuning short-wave stations are very easily detected by this visual indicator where the ear usually misses them. Easily installed on any receiver by placing it in series with the plate of the power tube. Shipping wt. 1/2 lb. Available in two styles.

TM-103—(Illustrated) Enamel finished dial—lighted from that side of the case over the top of the dial.
TM-100—Translucent dial—lighted from a rear window. Your Price **\$90**
List Price \$1.50.
Escutcheon Plate\$25 extra
Pilot light and bracket.....\$30 extra

★ VERSATILE PORTABLE PUBLIC ADDRESS SYSTEM

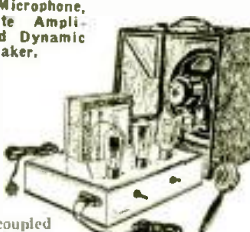

Comprises Microphone, Loftin-White Amplifier and Dynamic Speaker.

A recently completed all-electric A.C. development incorporating all the features and advantages of the direct-coupled Loftin-White Amplifier principle.

The amplifier is a high quality two stage job, having some **RADICALLY NEW IDEAS IN AUDIO FREQUENCY AMPLIFICATION** and employing 1-27, 1-15 power tube and 1-80 full-wave rectifier. It is remarkably free from A.C. hum.

The design is adaptable to all purposes, i.e., microphone, radio and phonograph. Has an undistorted power output of approximately 3.5 watts; **SUFFICIENT TO OPERATE FROM 2 TO 3 ADDITIONAL DYNAMIC SPEAKERS.**

The portable address system is sold COMPLETE WITH THE NEW R.C.A.-VICTOR HAND MICROPHONE—a sturdily constructed unit which will withstand a lot of rough handling.

Put up in a single compact and perfectly balanced carrying case, the front of which is utilized as a baffle for the self-contained dynamic speaker. Complete with microphone and accessories the weight is only 30 pounds. For 50-60 cycles, 110-220 volts A.C. operation. Shipping weight 38 pounds. List Price, \$75.00.

No. S.P. 9063—Versatile Portable Address System. Your Price, complete with microphone **\$25.50**

★ UTAH A.C. DYNAMIC SPEAKER—Only a Few Left



110-volt, 60-cycle A.C. light socket supply for field excitation with Westinghouse dry rectifier. 9 in. high, 9 1/2 in. wide, 7 1/2 in. deep. Speaker comes packed in wooden case. Weight 19 lbs. It is one of the most powerful as well as best reproducers in the market. 9 inch cone. List Price, \$50.00. No. S.P. 1506—Your Special Price **\$7.45**

FREE 76 Page Radio Treatise No. 24



The new Winter edition of our **RADIO SERVICE TREATISE**, twice as large as our former one, has just come off the press. It is positively the greatest book in print—**NOT JUST A CATALOG**. It contains a large editorial section—a veritable book in itself—with valuable information **NOT FOUND ANYWHERE ELSE**. Among the wealth of new technical information listed in the editorial sections are the following: 1932 Complete Radio Characteristics **SHORT-WAVE TUNERS AND PHONO-PICKUPS**.—Constructional Data of **SERVICEMEN'S TEST OSCILLATOR—ALL ABOUT TONE CONTROLS—SHORT-WAVE ADAPTERS AND CONVERTERS—CONSTRUCTING A 3-TUBE SUPER-HET SHORT-WAVE CONVERTER—MODERNISING OLD RADIO SETS—LATEST TYPE MULTI-MID AND PENTODE TUBES—ALL ABOUT DC RECEIVERS—VACUUM TUBES TREATISE**.—And dozens of new radio experiments, hints to Servicemen, valuable tables of useful data, etc., etc.

This book is not just another catalog but a veritable mint of radio information which will be of infinite and everlasting value to you.

WRITE TODAY. Enclose 2 cents for postage. Treatise sent by return mail.

★ FARADON 4-MFD. FILTER CONDENSER



Here is just the condenser for constructing noise filters. In some cases one condenser connected across the line or instrument will be sufficient. However, in most commercial filters there are two condensers connected in series; the center-tap being grounded and the two remaining leads connected across the light line or the interference-producing apparatus. Put up in a neat, black-enamelled case with tinned lugs for soldering connections. 2" high x 3 1/2" wide x 2 1/4" deep. Working potential 600 volts A.C. Ship. wt. 6 lbs. List Price \$7.50. No. S.P. 9062—Faradon 4 Mfd. Filter Condenser. Your Price **\$1.50**

100 New Hook-Ups, etc. 675 Illustrations.

6 MONTHS GUARANTEED NEOTRON TUBES

Sold on a 6 MONTHS FREE REPLACEMENT GUARANTEE BASIS, PROVING TUBE LIGHTS! All tubes are carefully meter-tested before shipment, and carefully packed. Do not confuse these HIGH QUALITY tubes with any other "low priced" tubes—our low prices are possible because we do a VOLUME business!

NEW					
Choice 226	Choice 112A	Choice 245	Choice 222	Choice 235	Choice 237
227	200A-199X	280	210	232	234
171A	199UV-120	171	250		236-37
201A	224		281		551
60c ea.	69c ea.	70c ea.	1.58 ea.	1.08 ea.	1.08 ea.

R.C.A. LICENSED TRIAD AND SPEED TUBES

These nationally advertised tubes are guaranteed UNCONDITIONALLY for six months. The prices are slightly higher than our NEOTRONS because these tubes are of much better quality. See listing above for tube numbers.

Choice Price	Choice Price	Choice Price	Choice Price	Choice Price	Choice Price
63c	80c	75c	\$1.76	\$1.15	\$1.15

★ R.C.A.-VICTOR HAND MICROPHONE



The most ruggedly constructed hand microphone ever manufactured. There is not another of its kind that is quite as sensitive. Designed especially for home recording and personal entertainment. Requires but a 2 1/2 volt battery to operate. Easily connected to any radio or amplifier in a few minutes. This unit is essentially a single button carbon microphone—acoustically centered in a stout metal housing which serves the dual purpose of protection and noise shielding. Responds indiscriminately to all speech and music frequencies. Has a high D.C. resistance and may therefore be slumped directly across the grid and cathode of the detector tube without employing a coupling transformer. Sold complete with 6 ft. connecting cable. Shipping weight, two pounds. List Price, \$10.00. No. S.P. 9064—R.C.A.-Victor Hand Microphone. Your price **\$2.75**

World-Wide Short-Wave Set NOT A CONVERTER



A perfect radio short-wave receiver for use between 18 and 200 meters. To put into operation, connect antenna, ground, 15-volt "B" and two No. 6 dry cell "A" batteries to and headphones to the posts provided, plug in a type "30 tube, and tune in! An ingenious circuit makes possible a 4-coil single-winding plug-in design. This little instrument has the same sensitivity as many big, shielded short-wave receivers costing ten times as much. A power amplifier may be added for any degree of volume. Complete with 4 plug-in coils, has fine vernier dial for precision tuning. Never has a first class short-wave set sold for so little money. This short-wave set measures 5 1/2 x 7 1/2 in. high, over all. Ship. weight, 3 lbs. List price, \$12.50. No. 1666—World-Wide S.-W. Set. Your price **\$6.25**

★ "POROX" 2-VOLT STORAGE CELL



5 Ampere-Hours—For 2-Volt Tubes

One such unit will light a two-volt battery tube for 75 hours continuously. Will handle two 2-volt tubes for 35 hours, etc. Put up in a transparent composition container with two non-corroding terminals clearly marked as to polarity. Easily recharged either directly from a 110 volt D.C. line in series with a 10 watt electric light bulb or from an "A" eliminator in series with a 12 ohm 2 watt resistor. Excellent for use in any circuit requiring a steady source of current. 2" wide x 1" high x 7/8" thick. Instructions included. Ship. wt. 2 lbs. List Price \$4.50. No. S.P. 9060—Porox 2 Volt Storage Cell. Your Price **\$80**

★ 6-VOLT BATTERY PHONO-MOTOR



At last a REAL battery motor—designed especially to meet the needs of semi-portable and portable address systems especially installations on moving vehicles. It will easily and economically operate from 6 volt storage battery or the equivalent in dry cells. Draws very little current. The entire motor is flexibly pivoted upon a metal frame and is held taut at all times by a compensating spring, thus assuring positive contact of the friction drive gear against the inside rim of the turntable. This arrangement was designed to overcome the effects of bumps and jars experienced by moving vehicles. The motor is sold complete with 10 in. turntable, mounting plate and motor frame and is shipped complete. Shipping weight—in lbs. List Price, \$15.00. No. SP9058—6-Volt Battery Phonomotor. Your Price **\$2.50**

Screen Grid Cap Connectors



Newest SCREEN GRID CAP. Small, neat in appearance and nicely constructed. A stark necessity in service work. Sold only in lots of 12 or more. Shipping weight 4 oz. No. 1672—Screen Grid Cap Connector. Your price.....Dozen **\$1.12**

★ Guaranteed 8-Mfd. Electrolytic Condensers



Judiciously used in many parts of any R.F. or A.F. circuits, in power packs, in dynamic speakers, they will perform miracles in eliminating any trace of objectionable A.C. hum or other incidental disturbances. These electrolytic condensers are particularly recommended for 250 power packs. Where the working voltage of the unfiltered A.C. is 800 volts, two electrolytic condensers in series will stand up indefinitely. Easily mounted through the use of a bayonet socket base which is equipped with a "positive contact" spring. Totally shielded and protected by a copper cap. Shipping weight—1 lb. List Price, \$2.50. No. SP9054—Guaranteed 8 Mfd. Electrolytic Condenser. Your Price..... **\$49**

WE ARE A WHOLESALE HOUSE AND CANNOT ACCEPT ORDERS FOR LESS THAN \$3.00.
If C. O. D. shipment is desired, please remit 20% remittance, which must accompany all orders.
If full cash accompanies order, deduct 2% discount. Send money order—certified check—U. S. stamps.

Radio Trading Co.
25A West Broadway
New York, N. Y.

ORDER FROM THIS PAGE. You will find special prices from time to time in this magazine. Get our big FREE catalog for the greatest Radio Bargains. Should you wish goods shipped by parcel post, be sure to include sufficient extra remittance for same. Any excess will be refunded.



May, 1932

VOL. III, No. 1

H. GERNSBACK, *Editor*
H. WINFIELD SECOR, *Managing Editor*

The Short Wave Telephone

By HUGO GERNSBACK

IN 1911, the writer published the first book to appear on the subject, entitled "*The Wireless Telephone*". This was before the days of broadcasting and, as a matter of fact, before it was possible to even use a radio telephone without wires. The writer, at that time, made the prediction that the time would come when—to quote verbatim from the preface—

"The future use of the wireless telephone will be confined to the low-power or battery system . . . when every farmer will be able to operate his wireless telephone; when the sending and receiving instruments will be housed in a box a foot square."

Then came broadcasting which, of course, is another type of wireless telephony, whereby millions listen to a single station at one time. Still later on, the radio amateurs took hold of the radiophone and they are now using 'phone transmission actively in the lower wavebands for communication purposes among themselves, often spanning considerable distances. But the usual 'phone transmitter is in the waveband of 80 meters (there are also a number on 160, 20 and 5 meters), and, inasmuch as there is a tremendous amount of crowding, it is almost impossible to get clear transmission at the present time. For that reason, the rank and file of the radio amateurs prefer to work in "code", as a surer and better way of transmitting intelligently.

Obsolete Restrictions!

In the past few years, however, it has become apparent that, as the art progresses, it has developed possibilities of wide usefulness outside of the strict "amateur" field which, for a number of reasons, has been hedged in with a number of restrictions that today seem *obsolete!*

Most licensed transmitting amateurs today look with distinct disfavor upon radio telephone transmission, and perhaps rightly so, due principally to the overcrowded condition which makes good transmission a virtual impossibility.

There are, however, many individuals who are interested in radiophone communication who wish to enter the field, but cannot do so, principally because of the *code requirements*.

The U. S. Department of Commerce requires that everyone who wishes to transmit by radio telephone must not only be "licensed", but *he must know the code!* This, perhaps, is quite proper in the amateur band, but is an anachronism today in the lower wavebands, principally below 6 meters.

Why Knowledge of the "Code" Below 6 Meters?

There is today, no logical reason why a radiophone operator who uses his transmitter in the waveband of 6 meters and below, *should be required to know the code*, as it serves no useful purpose here. The code requirements have been a powerful deterrent, not only to those who wish to experiment, but those who wish to use the short-wave 'phone for a variety of purposes. Of course, we recognize the fact that every phone transmitter should and must be licensed by the U. S. Department of Commerce; but there is no useful purpose

gained today in requiring a man who wishes to use a short-wave 'phone in the lower waveband, to know the code.

It is difficult for almost anyone to learn the code. It has been found by our Government experts, that only a certain percentage of people can learn the code! There is always a certain amount who simply cannot master the code, and these people more often than not are excellent radio men, who are thus barred from owning radio telephone stations; when, *without the code requirement*, they could well serve to help advance the radio art.

It isn't, of course, simply the man who wishes to use the radiophone for experimental purposes who is to be considered; more important are certain industrial applications.

Vast Undeveloped Field for 'Phone

Take, for instance, a motion-picture company who wish to use *short-wave telephony* "on location" for communicating between two different "sets"; such a use is very common today. The knowledge of code does not help the operator one bit. Portable phone stations on inland river boats, in automobiles, in private airplanes, all can use short-wave 'phones without ever requiring the knowledge of code! The same is the case with point-to-point commercial phones between factory units; radio-phoning between the end car of a long railroad train and the locomotive; fireboats; tugs; mines; prospectors, and many others, the mention of which would needlessly lengthen the list.

It is recognized that if the *code* restriction were removed on the upper short-waveband, a lot of mischief might conceivably be done; because some of the phone transmitters on these higher bands have quite a range, but in the bands below 6 meters—irrespective of the power listed, the range is never greater than 75 miles. Still further down in the wavebands, the range is cut down progressively until we come to the ½-meter band, where the transmitter and receiver must be within "geometrical" sight of each other, if communication is to be effected. It will, therefore, be seen that in these ultra-short-wavebands, there will be little danger of *overcrowding* and *interference* because the "reach" or "range" is restricted.

We Advocate Limit On "Code" Requirements

It is for this reason that SHORT WAVE CRAFT has taken upon itself to be instrumental in having the *code requirements* in the ultra-short-waveband limited, and it is confidently believed that the Radio Commission will, in time, make the necessary amendment to the present ruling.

The idea is incorporated into one of the planks in the platform of the new SHORT WAVE LEAGUE. In order to get the movement under way, it is requested that all who are interested in owning short-wave *telephone transmitters* send their petitions to SHORT WAVE CRAFT, stating the reason and proposed use for their transmitters. If a sufficient number of such letters are received, they will form the basis of negotiations between the LEAGUE and the Federal Radio Commission.

SHORT WAVE CRAFT IS PUBLISHED ON THE 15th OF EVERY MONTH

THE NEXT ISSUE COMES OUT MAY 15th

SHORT WAVES *in the* PUBLIC EYE



Dr. Marconi testing ultra short waves in Italy.



3 meter short waves light lamp with 5 ft. aerial at Westinghouse Laboratory.

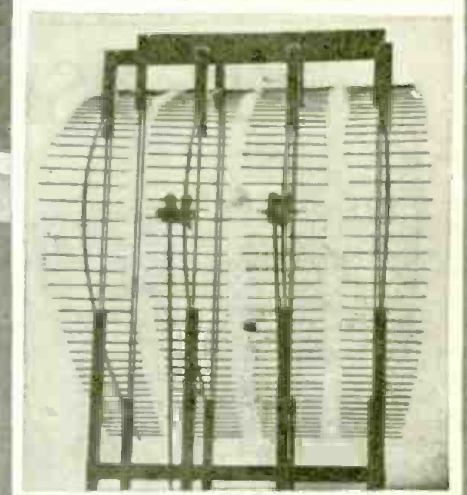

Marconi's ultra short wave antenna.

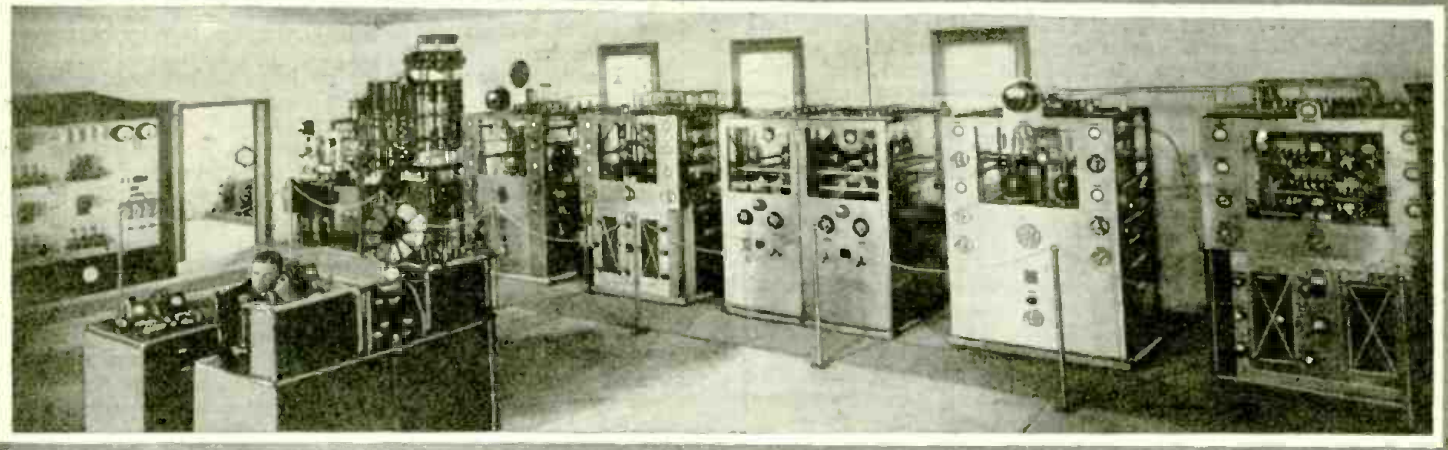

Above—The powerful short wave transmitting station, VK3ME, at Melbourne, Australia, which station is frequently heard by short wave enthusiasts in all parts of the U. S. The wavelengths used by this station can be checked up in the list of "Short Wave Stations of the World," published elsewhere in this issue.

Left—Auxillary right antenna at Geltow, Germany, used for reception from South America (Telefunken).

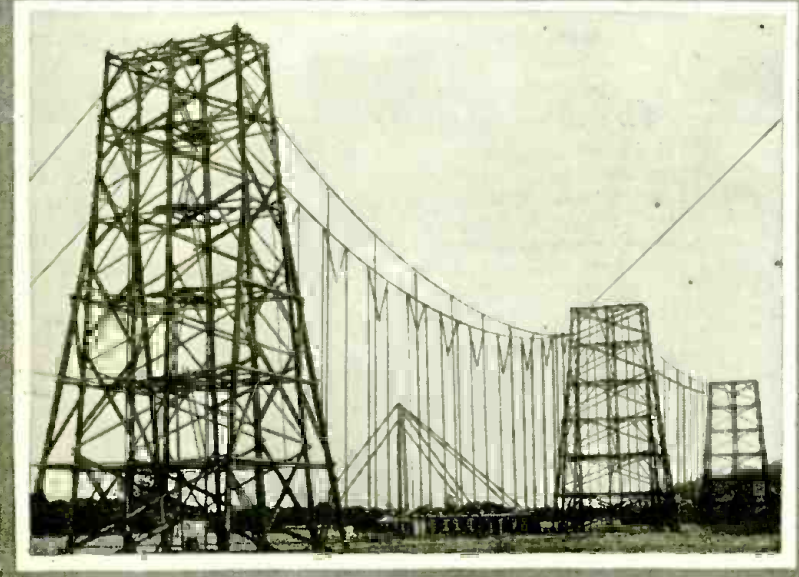

IN the short wave news illustrated, we find two interesting photos of Senator Marconi's ultra short wave antennas of the reflecting type, which he has constructed at his villa on the Ligurian coast, where he is engaged in making tests of ultra short wave transmission and reception. The third photo shows three meter waves oscillating at 100 million times a second. This tremendous frequency causes lamps within 40 feet, to be lighted—cooks food in a few seconds and raises body temperature one degree per minute. H. V. Noble, Westinghouse research engineer, is shown explaining the phenomena to the two young ladies. The lamp shown lighted in the photo is connected to a 5-ft. aerial and the powerful electro-magnetic field is produced by a standing wave oscillator, which sends out from the antenna overhead 15,000 watts of ultra short wave power. The photo extending across the page shows the magnificent short wave layout of the famous station, VK3ME, in Melbourne, Australia. An elaborate short wave receiving antenna is shown in the photo in the lower left-hand corner of the group, and this is used for the reception of short wave messages from South America as they reach Geltow, Germany.

HONOLULU to NEW YORK on the *SHORT WAVES*

A new broadcasting link in the N. B. C. network was recently introduced to the American radio public, thanks to short waves, which carried tinkling tunes from Honolulu across 2,800 miles of the vast Pacific on short waves.

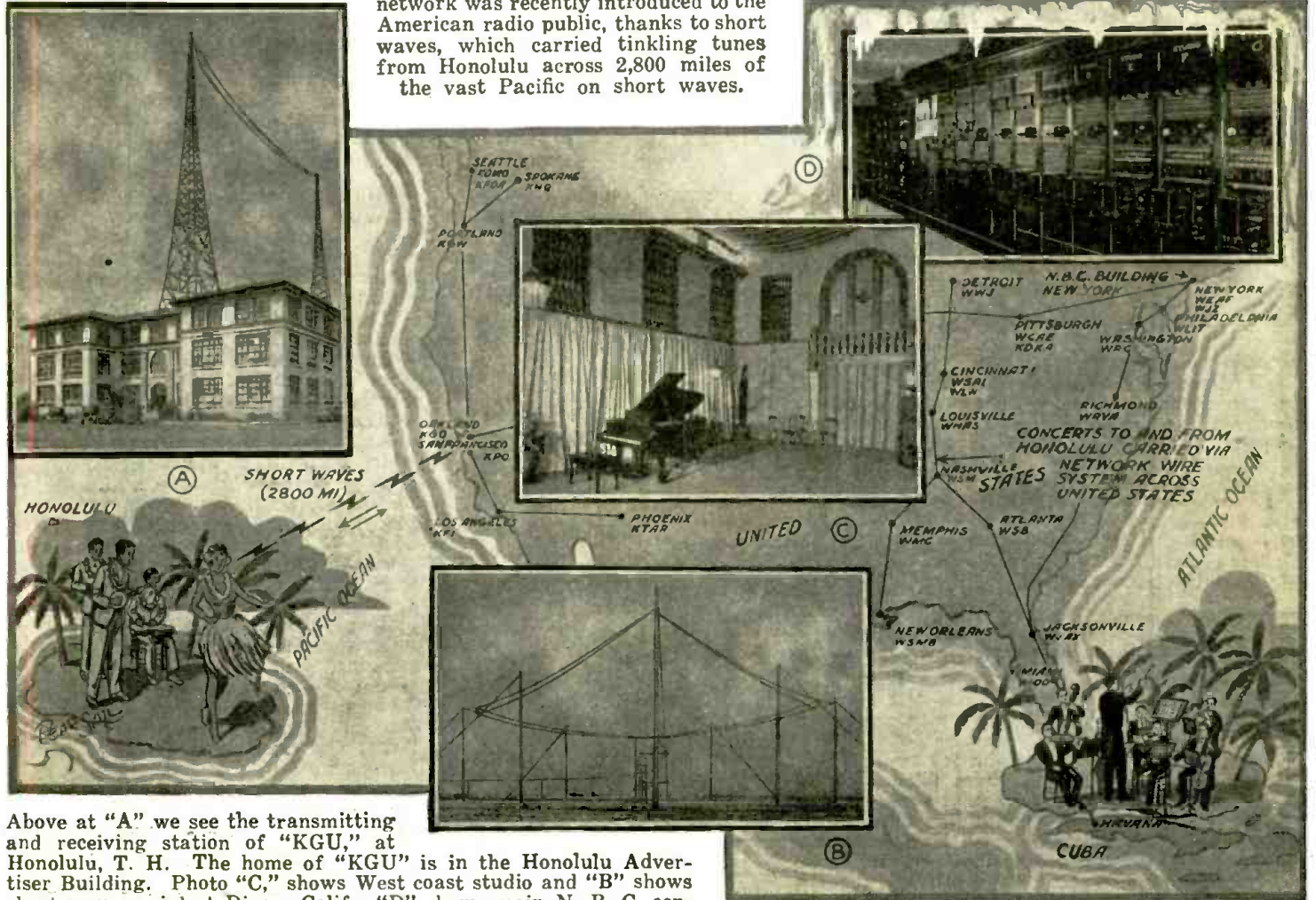

Above at "A" we see the transmitting and receiving station of "KGU," at Honolulu, T. H. The home of "KGU" is in the Honolulu Advertiser Building. Photo "C," shows West coast studio and "B" shows short wave aerial at Dixon, Calif. "D" shows main N. B. C. control room at 711 Fifth Ave., New York City.

A FEW months ago the American radio public was pleasantly entertained with a very unusual program, when the latest link in the N. B. C. network, "KGU," Honolulu, was formally introduced. It is intended to supply programs from New York and other American cities to Honolulu over the N. B. C. network wire systems to the west coast, where the programs will travel via short

waves, 2,800 miles to Honolulu. Programs were sent to and from Honolulu on the opening event and Honolulu, as well as American listeners to N. B. C. stations, also heard an orchestra play in Havana, Cuba. The Havana concert traveled by wire up the east coast to the N. B. C. headquarters in New York City. Probably one of the greatest thrills that anyone could imagine, was that when the

announcer proclaimed the fact that the radio audience was about to hear some of the famous string music being played by a well-known orchestra in Honolulu. Thanks to the slight static interference encountered on short waves, the service between the mainland and Honolulu, should be very satisfactory even in the summer.

In Our Next Issue

A NEW SHORT WAVE SUPER-HETERODYNE — With Photographs, Drawings and Full Explanatory Article. Designed, Constructed and Tested by Clifford E. Denton.

A NEW "CRYSTAL-LESS" SYSTEM OF "FREQUENCY CONTROL" FOR TRANSMITTERS. By C. H. W. Nason. In Which Diagrams and Data Are Given for a 10-Meter Transmitter Layout.

EXPERIMENTING WITH ULTRA SHORT WAVES. By Hanns Günther. With Drawings Showing How to Build the Apparatus for Producing and Intercepting Waves But a Few Meters in Length.

A STENODE FOR SHORT WAVES. By John B. Brennan, Jr. How a Quartz Crystal Can Be Used in a Simple Way to Greatly Improve the Selectivity on Your Receiver.

A PORTABLE SHORT WAVE RECEIVER THAT FITS IN A LEATHER "BRIEF CASE"—Comprising All Necessary Coils, Condensers, Tubes, Batteries and 'Phones—the "Slickest Job" Yet—and How It Works!

HOW TO ELECTRIFY THE DENTON STAND-BY 3-TUBE SHORT WAVE RECEIVER DESCRIBED IN THE APRIL ISSUE.



Heinrich Hertz, who laid the groundwork of present-day radio. The seventy-fifth anniversary of his birth was observed by the scientific world on February 22.

"If anything actually happens to me, you are not to sorrow but to be a little proud and to think that I belong to those especially selected, who live only briefly and yet live enough."

THESE words were written by Heinrich Hertz in his diary on the 9th of December, 1893, four weeks before his death. Nothing can better characterize the man, his life, the sum total of his activity, than this utterance. Less than four decades compassed the span which was granted him for remaining on earth. But this was filled with a lofty purpose, with constant successful work. It led to the heights of fame. The work which Heinrich Hertz left behind to posterity means the beginning of a new development, the extent of which cannot be seen even today.

But the content of what he did and left to us has been summarized by no one more strikingly than by himself. It was in the year 1889 at the assembly of natural scientists at Heidelberg, where he expressed himself as follows regarding his experiments:

"The rule of optics is not limited to

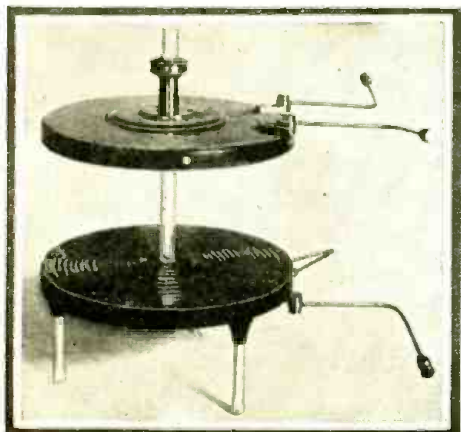

Induction spiral designed by Knochenhauer. Observations with this apparatus induced Hertz to make his epoch-making discoveries.

HEINRICH HERTZ

What of the boyhood of radio's greatest idol? When did he start to study theoretical physics? What was Hertz's early opinion of electrical theory? These and other interesting questions are here answered.

By DR. ALBERT NEUBURGER, Berlin

ether waves measured by small fractions of a millimeter, it is gaining waves whose lengths are measured in decimeters, meters, kilometers. And in spite of this en-



Heinrich Hertz at the age of three (right), and his younger brother, Gustave.

largement it appears seen to us from here as only a small bit of the field of electricity."

This signifies simply that Heinrich Hertz pointed out to us the way to govern the entire field of electrical waves in its full extent. He teaches us that light waves and electrical waves obey the same laws, that there is really no basic difference between them, that they differ only through their length. The production and governing of electrical waves is, however, a field whose theoretical knowledge opened up a mighty new land in the realm of pure science. Daily we are now experiencing with amazement some of its mysterious wonders: *wireless telegraphy and telephony, picture telegraphy, radio, television.* But will the series of possibilities be closed with these mentioned, or will still more result from the Hertzian experiments, performed with such simple apparatus? Who would venture to answer this question today, when so many new wonders are coming into being almost daily?

A remarkable fate willed it for Heinrich Hertz to have opened up to him the path which was to lead to such brilliant results. Originally it was his intention to adopt a totally different profession than that of a physicist. He was born

in Hamburg on the 22nd of February, 1857, his father being a lawyer. In his youth his mother occupied herself much with him. Later, after his death, she wrote her memories of her great son in an affectionate way. With clear vision she recognized the innermost trait of his character. *"He was really not ambitious, only very eager,"* she said. In that sentence she stated briefly and to the point all that there is to be said about the work and striving of Heinrich Hertz. He did not seek glory or honor. The goal which he had set for himself he pursued however with the greatest zeal. He kept his eye on it, whether it was a matter of school work or the physical investigation of the phenomena of oscillation. What the mother's eye so clearly recognized was later confirmed by Hertz's diaries. When he was at his experiments, the most beautiful sun could not lure him away; while it was joyous outside, he remained in his darkened laboratory, where one could not stretch and move, because one would most likely receive electric shocks at any incautious movement; he remained in his "witch's kitchen."

Another characteristic appeared in his youth: delight in what we today call "tinkering." From a child he was, as his

(Continued on page 48)

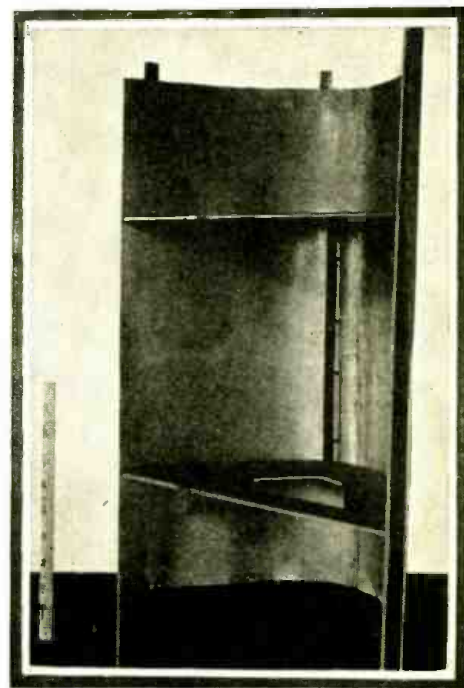

One of Heinrich Hertz's paraboloid reflectors which he used for receiving radio waves.

\$500.00 SHORT WAVE BUILDER'S Contest—\$100 in Monthly Prizes for Best Models

THE publishers of SHORT WAVE CRAFT are pleased to present a brand new contest to their readers, in which everyone can join.

This is to be a special builders' and experimenters' contest, which has to do with building novel short wave sets, short wave converters, or short wave adapters.

The keynote of the entire contest can be found in the word—SIMPLEST. The purpose of the contest is primarily to induce people who have never built short wave sets to go into this fascinating art and to popularize short waves, just as in 1922-24 radio sets for broadcast purposes were popularized by having "radio fans" build them.

Of late, there has been such a tremendous interest manifested by the public in short waves that the publishers of SHORT WAVE CRAFT take it upon themselves to still further fan the flame by making this special prize contest.

When we say *simple*, we mean just that, and the sky will be the limit. Sometime ago we published the *Short Wave Junk Box* set, which was exceedingly popular because it used simple parts, but the present contest may even go that set one better.

Of course, we are not looking for "freak" sets. For instance, such sets as vest pocket sets or radio sets built into a hat, or sets built into a fountain pen will not be considered with so much enthusiasm by the judges, as "honest-to-goodness" sets that people will be willing to build and feel proud to possess.

Sets should, of course, be built as substantial as possible. While some builders in the past have used pasteboard boxes, this is not considered good construction and is a step too far when it comes to the word "simple". There is such a thing as simplicity providing it does not go to extremes.

The main thing we are striving to accomplish is to have you experimenters build such simple sets, that any one with a fair ability for using simple tools can duplicate your set, and still have one that works, and works well. We have seen sets built in cigar boxes that were really excellent, and we have even seen sets built into a walking cane, complete with batteries and everything else, that also were

By HUGO GERNSBACK

How to Build the "SIMPLEST"

SHORT WAVE SET SHORT WAVE ADAPTER SHORT WAVE CONVERTER

little marvels. On the other hand, we have also seen small portable sets built into typewriter cases and tool boxes that were substantial and had a great deal of utility, particularly for vacation purposes, etc. These are just a few hints that we have given to you in the hope that from them something real may come of it.

In these pages we have listed the six outstanding requirements. It may not be possible to build every set in which all the six requirements are embodied. If you cannot get the six, try for five or for three. Sets will be judged for highest merit points from these requirements.

But please read this carefully, and do not jump at any conclusions. Read especially the rules to make sure that you understand what it is all about, and you will have as good a chance to win a prize as anyone. Remember also, that THIS CONTEST RUNS FOR FIVE MONTHS.

Note particularly, that the prize contest does

not center itself about a single set. You can build one of the three following:

1.—Either a straight-forward short wave receiving set (it may be battery operated or for A.C. line voltage operation);

2.—Short Wave Converter;

3.—Short Wave Adapter.

Each of the three will be considered alike by the judges, so it will not make any difference which one of the three types you build. Each type of set will have the same chance of winning the first prize, the only requirement being that it fills the highest number of points as decided by the judges.

You can use any material, any sort of radio components, any sort of container, box or envelope that you wish to choose in building this set. All material, with such exception as the tubes for instance, can be home-made, if you choose to do so. You can even make your own condensers, if such should be necessary. The set can be built in any size or shape that you may wish to adopt, and you have the widest possible leeway in this. But remember always, that one of the important requirements is *workmanship!* Just a bunch of "junk" thrown together will not win a prize!

Important

Remember, that this is a builders' contest. From this contest, therefore, are barred just plain ideas and sketches which you might think up. For this reason, THE SET MUST BE BUILT BY YOU! And furthermore, the sets must be sent to the editorial offices of SHORT WAVE CRAFT. Therefore, just plain sketches and "ideas" of how a set could be built will not be acceptable in this contest. Whenever possible, try to get some novel twist, a new hook-up if that is possible, or something that shows ingenuity in the building of your set.

You readers of SHORT WAVE CRAFT have been dabbling with short waves for so many years that you have gotten a lot of experience while playing around at the game; back in your heads—somewhere—you undoubtedly have some novel idea that you have dreamed of playing up. Now is your chance to do it and do it right!

(Continued on page 53)

MAIN REQUIREMENTS OF SETS

1. Simplicity.
2. Compactness.
3. Ingenuity.
4. Novelty of Circuit Used.
5. Portability.
6. Workmanship.

Rules for \$500.00 Short Wave Builder's Contest

DURING the next five months, SHORT WAVE CRAFT will award a total of \$500.00 in prizes in an important new contest. You are asked to build a home-made short wave set which should fill one or more of the following requirements: 1, Simplicity;

2, Compactness; 3, Ingenuity; 4, Novelty of Circuit Used; 5, Portability; 6, Workmanship.

Read carefully the text of the adjoining article, and observe the following simple rules:

1.—Short wave sets submitted may be in either of the following classes:

"Straight" S-W Receiving Set (battery operated or A.C. operated)

Short Wave Converter
Short Wave Adapter

2.—Sets must be home-made and built by contestants themselves. Manufactured sets are absolutely excluded from this contest.

3.—Sets submitted may be for ONE, TWO, THREE and NOT MORE THAN FIVE TUBES. Any type of tube as selected by the builder can be used. Crystal operation or crystal-tube combinations allowable, at the option of builder. Sets may be of any size or shape, at the option of the builder.

4.—In order to win a prize, it is necessary that the set itself be submitted to the editors. The five best models submitted each month will be awarded the prizes as scheduled here.

5.—All sets submitted to SHORT WAVE CRAFT Magazine will be returned to their owners after they have been judged and described for the benefit of SHORT WAVE CRAFT readers in the magazine.

6.—This is a monthly contest, beginning May 1st, 1932, and lasting for five months. Each monthly contest closes on the 1st of the following month.

Thus the contest for May closes Midnight June 1st, 1932, at which time all entries for this month must be in the editorial offices of SHORT WAVE CRAFT. The first prize-winning announcements will be made in the August, 1932, issue of SHORT WAVE CRAFT.

7.—Every set must be accompanied by an article written by the builder, and contain not more than 2,000 words, giving minute instructions with wiring (schematic) diagram, list of parts with values of all resistors, condensers, coil data, including number of turns, etc., how the set was built, its operating characteristics, what stations have been received with it, and other information considered important by the builder. Such article should be typewritten or written in ink, and should be sent separately by mail, and should not be included with the set itself!

8.—All sets must be shipped in strong wooden boxes, NEVER in cardboard boxes. All sets must be sent "prepaid"! Sets sent "charges collect" will be refused. SHORT WAVE CRAFT Magazine cannot be held responsible for breakage in transit due to improper packing of sets. Before packing the set, be sure to affix tag with string giving your name and address to the set itself, IN ADDITION, PUT YOUR NAME AND ADDRESS ON THE OUTSIDE OF THE WRAPPER OF THE PACKAGE.

9.—Employees and their families of SHORT WAVE CRAFT are excluded.

10.—The judges will be the Editors of SHORT WAVE CRAFT Magazine, and the following short wave experts: Robert Hertzberg, Clifford E. Denton. Their findings will be final.

11.—Address all letters, packages, etc., to Editor, SHORT WAVE BUILDER'S CONTEST, care SHORT WAVE CRAFT Magazine, 96-98 Park Place, New York.

FIRST PRIZE	\$50.00
SECOND PRIZE	25.00
THIRD PRIZE	12.50
FOURTH PRIZE	7.50
FIFTH PRIZE	5.00



The author, Mr. Kurt Nentwig, one of Europe's leaders in ultra-short wave research.

Simple Transmitters and Receivers

for ULTRA Short Waves

By KURT NENTWIG
Berlin

Practical information on building and operating ultra short wave transmitters and receivers is here given by one of Europe's foremost radio experts. Phone modulation of U. S. W. transmitters is explained.

FROM all sides it is heard that specialists for some time have been devoting their particular attention to ultra-short waves. The Reichspost Central Office is also at present occupied with detailed investigations concern-

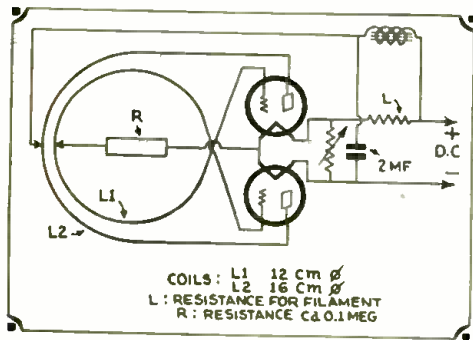

Fig. 1—Hook-up of the ultra-short wave transmitter.

The Transmitter

First let us study the transmitter, the hook-up of which appears in Fig. 1. Since there is no tuning condenser, the wavelength of the transmitter is not variable. In itself the use of a tuning condenser would indeed be advantageous, but it can very well be neglected, so far as there is only a question of experiments over small distances. (Though the fact is self-evident, it must be mentioned again here that even for such experiments a permit from the Department of Commerce is necessary.) The diagram furthermore shows that the two tubes of the transmitter are in push-pull hook-up, in order to obtain as much symmetry as possible for the whole arrangement. Then, in bridging rather small distances all chokes can be done away with in the battery wires, which is of advantage with regard to simplicity of design. In the case of the hook-up given, the feeding of the tubes is done entirely from the D.C. network (110 volt supply system). In the case of A.C. supply circuits a rectifier is built for the plate potential. To purify the plate potential somewhat, there is a filter in the supply circuit,

consisting of a choke and a fixed condenser of 2-mf. capacity. The choke is to be so constructed that, without further

ing the practical possibilities of the transmission and reception of ultra-short waves. Therefore amateurs not yet familiar with this field of radio technology might welcome some hints bearing on the construction and operation of ultra-short wave sets.

First of all, experiments with ultra-short waves require a real amount of patience; since otherwise good results can hardly be expected. On the other hand, the cost of such experiments is comparatively slight, on account of the small need of material. The following instructions deal with the construction of a simple transmitter and a receiver for ultra-short waves. An extensive set of building instructions with measurements, etc., can be dispensed with; since, in the exact following of the hints given, errors are hardly possible.

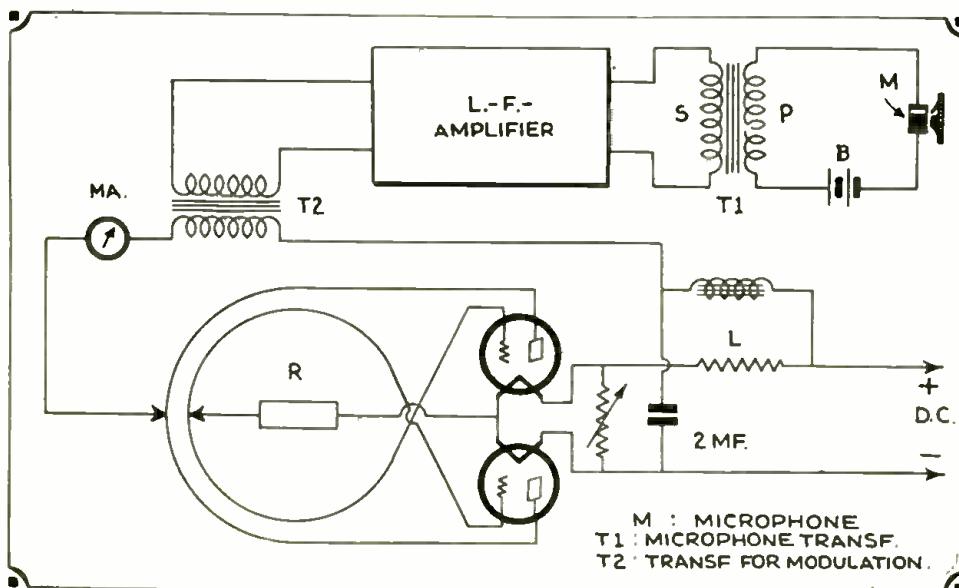

Fig. 4—How the transmitting hook-up shown in Fig. 1 is to be changed for telephonic experiments.

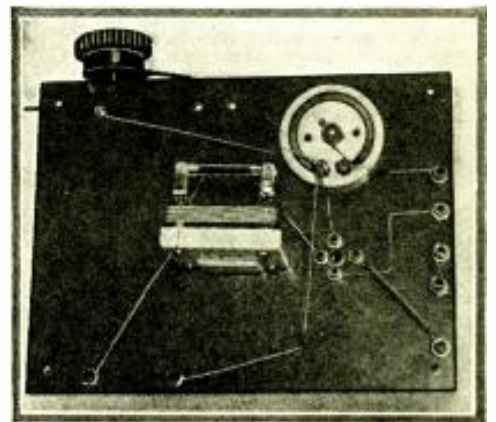

Fig. 7—The ultra-short wave receiver seen from below.

additions, it operates perfectly even with a load of 60-100 milliamperes. Between the middle of the two series-connected tube filaments and the tap of the grid circuit coil, there is a resistor capable of carrying a high load, the size of which must be tested out. It has the purpose of avoiding so far as possible an overloading of the tubes. To be sure, instead of the resistor one could regulate them by a grid bias; but using the resistor saves space. Regarding the tube sockets, note that they must be as free from capacity as possible.

Heating Circuit

Now a few words about the heating of the tubes, which, as said above, like-

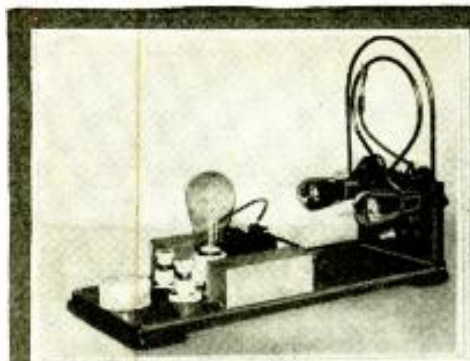

Fig. 2—Photo above shows the complete ultra-short wave transmitter as it looks when viewed from the side. Mr. Nentwig explains how to build and operate this type of apparatus in the article.

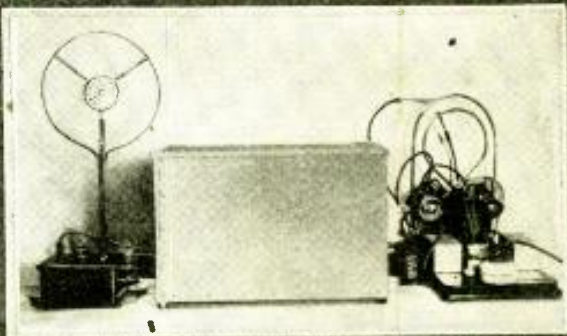
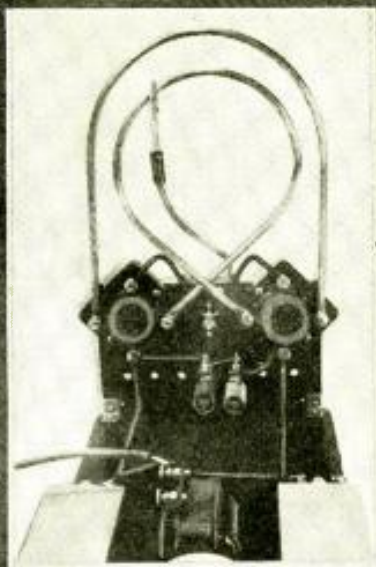

Fig. 3—At left, the ultra-short wave transmitter as seen from the supply terminal end.
Fig. 5—Above, shows arrangement for phone experiments according to the hook up as shown in Fig. 4, on preceding page; 'mike' at left.

wise takes place from the lighting circuit. With the indicated D.C. hook-up, there is provided as a series resistor a carbon filament lamp, L, whose current consumption is to be somewhat greater than that of the tubes. The excess potential is absorbed by a filament ballast shunted across the filaments.

The grid coil, L1, has a diameter of about 13 cm. (5.2 inches), while the diameter of the tickler coil, L2, is about 16 cm. (6.4 inches). For making the coils

two filament ballasts instead of one. This fact was, however, merely accidental, because there was none of sufficiently large resistance at hand.

No Antenna for Short Distances

For short distances no antenna is required for transmitting; if, however, an antenna is to be used, then a dipole is connected with a coil of about 14-15 cm. (5.6 to 6 inches) diameter, which is loosely coupled with the coils of the transmitter. If the transmitter is to be used for telephonic experiments, then proceed according to the diagram shown in Fig. 4. The corresponding design is shown in Fig. 5. The same arrangement can, of course, be used not only for transmitting speech, but also for transmitting phonograph records. In this case, in place of the microphone transformer, an electric phonograph "pick-up" is connected to the input of the audio-frequency amplifier.

Modulation System

The method used in the transmitting hook-up in question is plate modulation. Instead of this system we may, of course, use any other method such as grid modulation.

When the transmitter is completely constructed, it must be made to oscillate. Whether the transmitter oscillates, or not,

on both coils must be varied, until the desired effect occurs. In case of necessity, one can also make use of the filament ballast to change, very carefully, the heating current of the tubes. By these measures the transmitter can, in any case, be made to oscillate.

The wavelength of the oscillations produced is most simply measured by means of "Lecher wires". The procedure has already been described several times. If one wishes to use a dipolar antenna, then its length can be directly calculated ac-



Fig. 8—Complete ultra-short wave receiver for use of head-phones.

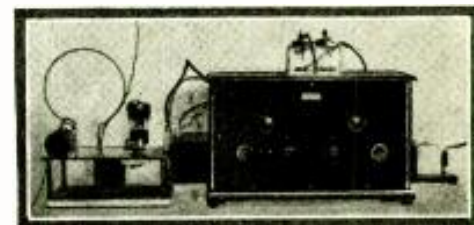
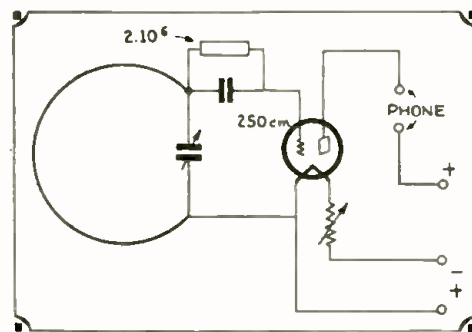

Fig. 9—The same ultra-short wave receiver with A.F. amplifier for loud-speaker operation.

copper pipe 6 mm. (.24 inch) in diameter was used; but copper wire about 0.12 to 0.20 inches (No. 8 to 4) in diameter renders the same service. The lengths of wire are for L1, 21 inches, and for L2, 20 inches. The ends of the coil-tubes leading to the plates or the grids of the tubes are fastened directly to the proper screws of the two tube sockets. For this purpose the ends of the coils are hammered flat and drilled through. The resulting edges are then rounded off as much as possible, so that no losses shall occur at these points. Tapping the two coils is done with suitable clamps; in such a way that they can be varied, in order to find the most favorable points easily. How this is done will be explained in the discussion on the setting of the transmitter into operation. Here let it simply be remarked that the most favorable tapping points are found but rarely at the "mechanical centers" of the coils.

Fig. 2 shows the completed transmitter viewed from the side, while Fig. 3 shows it from the supply current connection. It will strike the attention of the reader that the transmitter illustrated shows



Hook-up of an ultra-short wave receiver. Fig. 6.

can be easily checked up by putting a milliammeter into the plate potential wire. If the transmitter oscillates, then the indicator of the instrument, if the hand is brought near the coils, must show a greater deflection than before. If that is not the case, then the tapping points

according to the result obtained in measuring the wavelength. For experiments with the dipole the knowledge of the wavelength is absolutely necessary, if one wishes to bring the power of the transmitter to its maximum.

The Receiver

Now to the receiver, which, as appears from the hook-up diagram in Fig. 6, is constructed as a simple detector without any regeneration. The coil is made of solid copper wire 4 mm. (0.16 inch or No. 6), thick with a coil diameter of 17 cm. (6.8 inches). For tuning the grid circuit to the transmitter a neutrodon (neutralizing condenser) is used, the capacity of which allows wide variation. In making adjustments an extension handle is attached to the shaft of the condenser. As grid condenser we may use a fixed air condenser of 250-mmf. capacity. Fig. 7 shows the completed receiver from below, while Fig. 8 shows the construction ready for reception by means of head-phones. The two parts of the dipolar antenna visible in Fig. 8 are directly connected with the two ends of the coil. The grid-leak may be 2 megs. (Continued on page 59)

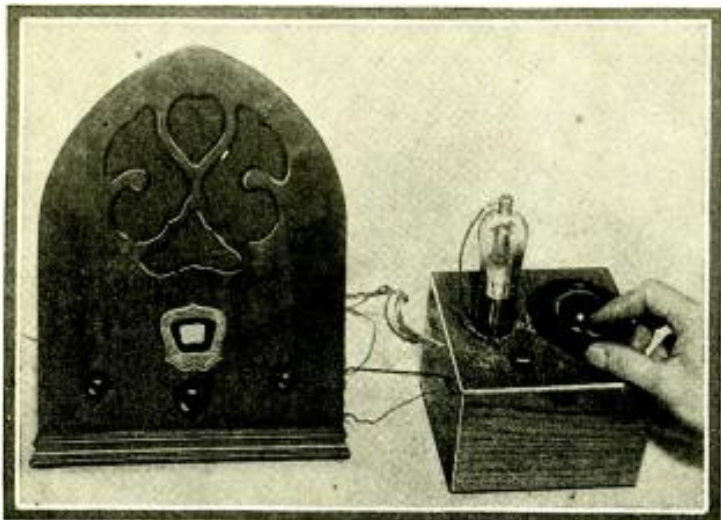

The short wave "Police Call" adapter unit connected to a "mid-get" broadcast receiver.

A POLICE SHORT WAVE

By H. GERNSBACK and CLIFFORD E. DENTON

Your present "broadcast" receiver, plus this inexpensive S-W converter, will bring you greater "real" thrills than those concocted by any detective story writer.

THE use of radio phone transmitters and receivers for the speeding up of communication facilities between police headquarters and the police cars is a new thrill for the listener-in.

Most of us being cursed with the fault of sticking our nose in other folks business and enjoying it will find that this is just the thing. Pardon me, I mean this new device which converts the average set be it tuned radio frequency or super-het into a device which will intercept the oral outbursts of information so necessary to the proper functioning of a well-regulated police department.

If you want to know how many automobiles have been stolen. If there is a riot on one of the side streets down by the gas house this is the very gadget to build. There has been some very fine statements covering small, medium and large size riots as well as other "racy bits of gossip" coming from various sec-

AT LAST, the short wave police adapter that WORKS ON ANY SET.

The editors have personally tried out this adapter on some twelve different sets in various localities, and have as yet to find the set or locality in which it does not work, and work well.

Police reports will roll in on this adapter from all over the country over the loudspeaker of your broadcast set, and the thrills in store for you are tremendous.

The cost of constructing the adapter is negligible, and is within the reach of everyone.

It is, in the opinion of the editors, the first fully "foolproof" police short wave adapter that has, as yet, been described.

The editors will be grateful to hear of the results obtained by those who construct this exceedingly interesting short wave converter.

and unless there are two audio stages before the speaker satisfactory loud-speaker results will not be obtained.

Most of the commercial adapters which we have tried out work only on certain

sets. It was found that a great many such adapters were exceedingly "tricky"; that is, they would work well on one set, but not on another.

It was, therefore, our endeavor to pro-

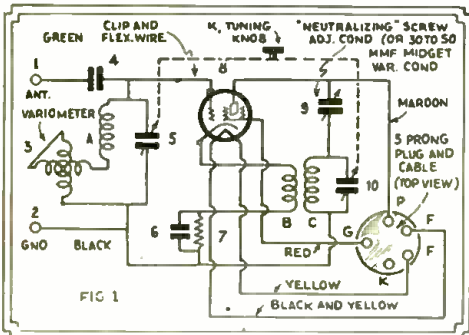

Right: Interior "close-up" view of Gernsback-Denton "police" and "short wave" adapter. The parts are few and the cost small.

Below: How police S.W. adapter may be switched "in" and "out" of circuit.

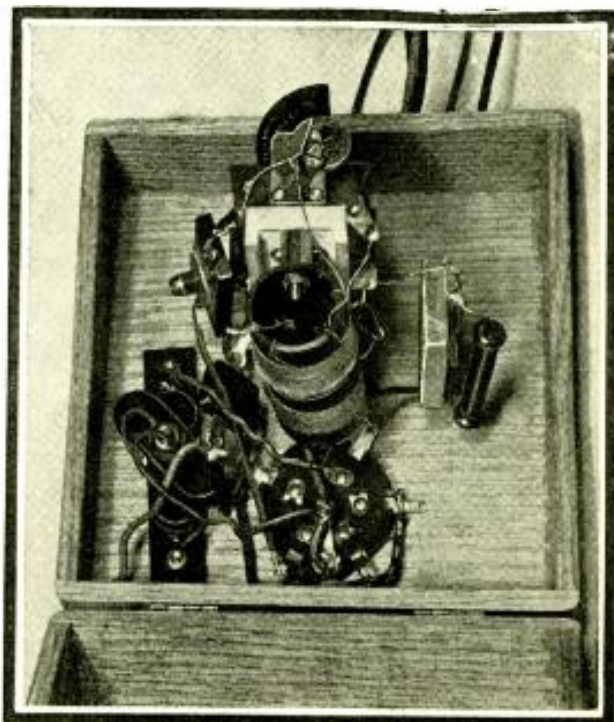

"Police Call" adapter circuit for use with '24, '35, '51 and '36 tubes. The 5-prong plug is inserted in the first R.F. socket in the B.C. set.

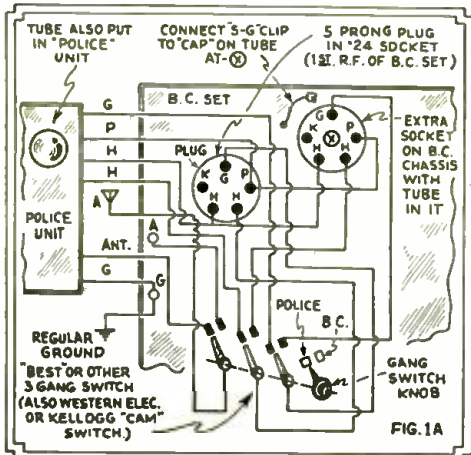

tions of the country, wherever the city has had sufficient funds left to finance the equipment for police purposes.

There are several "adapters" on the market at present and the authors are sorry to say they do not seem to operate with all types of standard receivers.

Most of the units on the market are simply plugged into the detector tube socket

“THRILL-BOX” THAT WORKS!

vide a circuit that would be “foolproof”, something almost too good to be true. A great number of experiments were made until finally a new circuit was developed, making use of a two-gang condenser, which seemed to solve the entire difficult matter. The new unit described here was tested on twelve different sets, which included radio frequency receivers as well

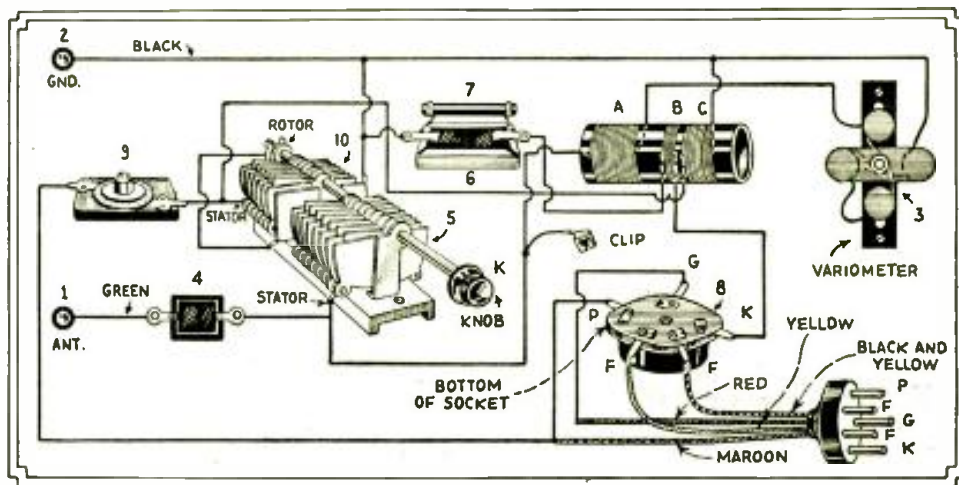

Picture wiring diagram which can easily be followed by the inexperienced reader.

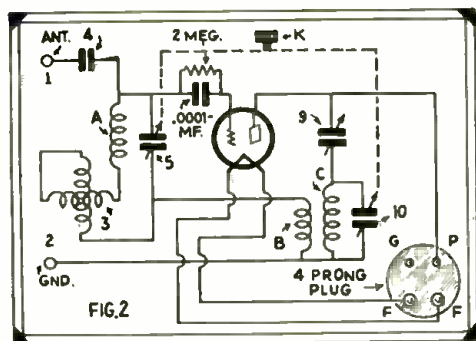

Hook-up of parts in police S-W adapter unit for use with 4-prong tube sets, using '01A, '12A, '99 and '30 tubes.

as superheterodynes, and we have as yet to find any set or discover any locality in which the adapter will not work. This is most gratifying, because the field that has now opened up is incalculable and the old bugaboo that disappointed constructors, at least in this particular class of adapters, may be said to have been done away with entirely now.

The ideal way to build a “police” unit of this kind is to plug in to the first radio frequency stage, be it “T.R.F.” or “Super-het”. This permits of the use of the total amplification of the receiver with resulting greater “gain” and “distance”. At first, the idea in designing this adapter was to use an additional tube for the oscillator, but this was discarded in favor of the circuit combining the function of the oscillator and the modulator in the same tube. The main draw-back in using the two tubes lies in the additional drain imposed on the power supply unit of the receiver being used.

The Electrical Circuit

For those interested in the theory involved in the operation of this simple all-around “police” unit, the following will be helpful.

The incoming signal is fed to the antenna tuning circuit through the small .00005-mf. mica condenser, Fig. 1. The grid circuit being tuned by the condenser “5”, coil A and vernier variometer 3. This vernier control is necessary as the two tuning condensers are mounted on the same shaft and some compensation

must be used to insure tracking of the tuning condensers with different types of antennas and radio receivers.

The tube has a bias produced by the voltage drop in resistor “7”. Condenser “6” bypasses the radio frequency currents developed in coil B and is an important part of the receiver.

The plate of the tube goes to the plate terminal of the five prong plug with a connection to the condenser “9” so that a portion of the signal current variations can be impressed upon the condenser “10” and the coil “C”. Coil “B” which is in series with the cathode of the tube completes the feed-back circuit and the energy developed in the tuned circuit C

99, 30 type the circuit in Figure 2 should be used.

Much interest has been shown in the use of screen grid tubes used as dynatron oscillators so the modification of circuit 1 is shown in Figure 3. The output of the converter unit is taken off through the screen grid connection of the tube. Thus the screen grid of the tube has a voltage of about 180 volts applied while the plate of the tube has the same voltage which would normally be applied to the screen. This voltage will be about 65 volts.

The coupling coil B is not used in this circuit. It is necessary to use the fixed condenser between the oscillator tuning condenser and the coil C due to the fact that the screen grid current has to flow through the winding and as the rotor of the condenser “10” is grounded there would be a short circuit unless condenser “11” is used.

How Coils Are Wound

Figure 4 shows how the coils A, B and C are wound. All of the windings are wound in the same direction. Be sure to do this otherwise the tube will not oscillate. If the tube will not oscillate when the unit is placed in operation reverse the winding of coil B. This can be done easily by simply reversing the leads. The lead of coil B which goes to the cathode of the tube is changed over to the common point of contact between 6 and 7. The lead which ran to 6 and 7 is then changed over to the cathode terminal. It may be that the particular tube will not oscillate. This can be checked by trying another tube in the socket on the adapter.

The tube socket is mounted on the top of the box to the rear. While the tuning

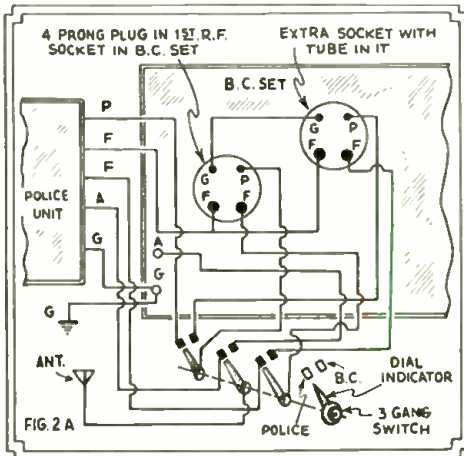

How 3-gang switch may be used to throw police unit into or out of circuit, with B.C. set using 4-prong tubes.

and 10 beats with the incoming signal to produce the intermediate frequency.

This intermediate frequency can be most any place between 250 and 500 meters. The best thing to do is to try several places along the dial (of your radio broadcast set) until you obtain the best results. In general the most satisfactory results will be obtained at the setting of the greatest receiver sensitivity. (The editors found the best setting just below WABC or 860 kc.)

Figure 1 shows the circuit for use with the following tubes: 24, 35, 51, 36 types. That is if the set with which the unit is to be used has any of the above-mentioned tubes, circuit 1 is to be employed.

For use with tubes such as 01A, 12A,

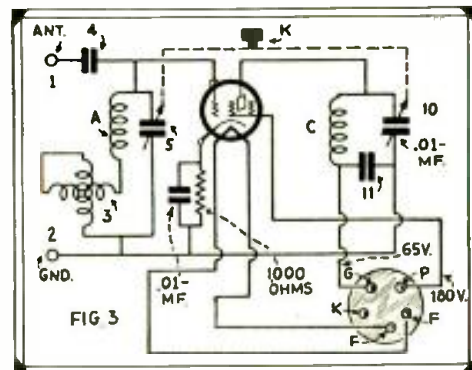

“Dynatron” hook-up of police S-W converter.

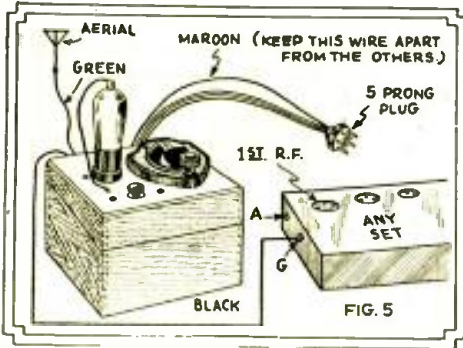

This picture shows how simple it is to connect the police adapter unit to the average B.C. receiver, using '24 tubes.

condenser with its K-K vernier dial is mounted front and center. The small knob on the left hand side of the top near the screen-grid connecting wire is the small vernier-variometer control.

The coil form is held in place by means of a small spacer with a brass machine screw and nut.

The bias resistor and its bypass condenser are soldered into place when the set is wired. Condensers 4 and 9 are also held in place by wiring. Be sure that all soldered connections are tight both mechanically and electrically so that the unit will not be noisy. The wires which hold condensers and resistors in place should be of solid copper and the other wires flexible rubber covered to minimize breakage.

It will be noted that all of the components are mounted in or on the cover of the box.

Do not twist the plate lead into a cable—keep it separated as shown or most of the available power will be lost. Adjust condenser 9 to match converter to coil in broadcast receiver, or until maximum signal strength is obtained on loudspeaker.

Figure 5 shows how to connect the adapter unit to any standard set using tubes indicated in Figure 1. The same scheme will be used when other types of tubes are used except for the changes as shown in Figures 2 and 3.

There is a lot of fun to be had in playing with and constructing a simple device of this kind and the author believes that the time spent will be well repaid by the results obtained.

If any one desires to ask any questions about this adapter unit he may do so by sending his questions along with a stamped and self-addressed envelope for return and the authors will be glad to help, so that they can enjoy the kick which is to be had tuning in police signals from various parts of the country.

Tuning

The important part to remember in connection with this adapter is that the tuning is critical. If you have never tuned a short wave set, you must first become accustomed to tuning this converter. You must be prepared to tune exceedingly fine with the vernier, because a hair-breadth change on the dial will throw stations in or out. It requires some patience to tune any short wave set, and the present converter is no exception to that rule. Do not expect quick results. Be patient!

When you first have the set connected up, do not just tune back and forward at random. Start at one side of the dial and slowly, slowly, SLOWLY tune, and

"THRILLS" YOU HEAR!!

... Scout Car No. 57 ... go to No. 410 Elm St., ... there's a burglar breaking in the rear window! ... Car No. 71 ... go to — and — Streets, there's a murder—emergency car on the way ... meet the officers ... Police Dept. —; ... Scout Car No. 62 ... there's a man in the cellar at No. — Spring St., ... Cars Nos. 4, 10, 24, 32 ... The Hanover Theatre has just been held up ... blonde young man walked out and went down street —no car ... wore gray suit ... brown derby ... brown overcoat ... Scout cars 6 and 7 ... shots fired out of second story window at 244 Desplains Street ... investigate and report to your station ... or dial DO1462.

(Actual excerpts from police reports as heard by the editors with this "Police Thrill Box".)

note down on a pad of paper at what point you hear various stations. It should take you about fifteen minutes to cover the entire waveband. If you do it quicker than that, you are tuning too fast! Re-

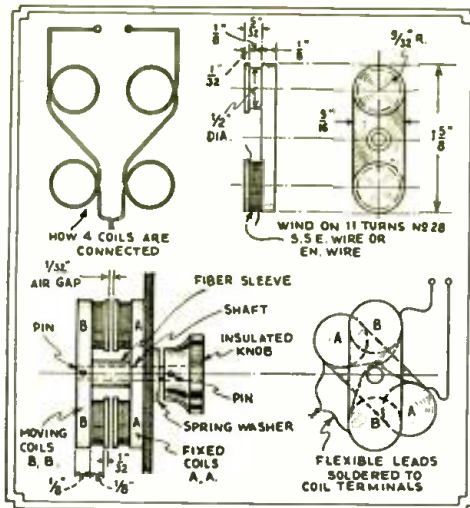

Construction details of variometer used in police S-W adapter unit. Other means familiar to radio constructors may be used in its place.

member also, that you will hear a lot of broadcast stations on this set. There is nothing wrong with this, because what

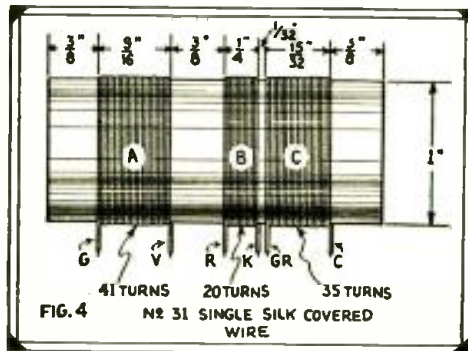

How the police adapter unit is wired up with 4-prong plug for use with B.C. receiver using '27 tubes.

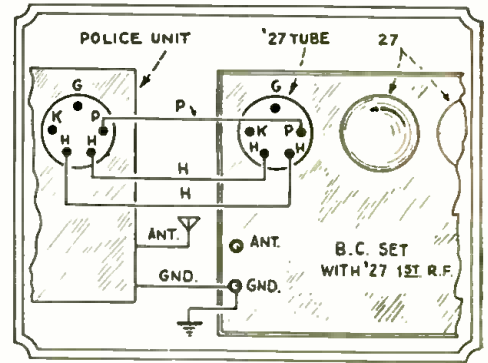

Data for winding three coils on tube, as used in building S-W police adapter unit.

you hear are not the broadcast stations or their high or regular wave length, but harmonics of the broadcast stations on the lower waves. Every short wave set tunes that way, so don't jump to the conclusion that the set is wrong.

When you finally hit the point where the police stations congregate, you will find that they all come in within about one degree of the dial. A glance at the police wave lengths in this issue will show you why this is so. It will be seen that all the wave lengths of the police stations are in the 121 to 125 and 175 to 180 meter bands.

Another glance at the police wave lengths will show that any number of stations operate on the same wave length. That again means only one thing, that is, a number of stations will come on top of each other, and there is nothing that you can do about it. If two police stations, say for instance Detroit and New York, are on at the same time, you will get nothing but a jumble, unless, of course, one station comes in weaker than the other, which is usually the case; the stronger station "comes through". Tuning will not help you, as you cannot tune out stations which are on top of each other, on the identical frequency, but as a rule they do not come all at the same time, because mostly the reports are very short anyway, and it is the exception that a police call lasts longer than fifteen or twenty seconds. Where stations are on different frequencies, of course, tuning will help, and you can then tune out one station and get others.

As a rule, the evening is best for reception of police calls, and it seems that there is usually greater activity in the evening than in the daytime, and you will consequently hear more calls.

Other Suggestions

Do not expect to get good results with an indoor aerial. Even though your broadcast set works wonders on an indoor aerial, your short wave set will not work well this way as a rule; that is, as far as distance is concerned. You should have an outdoor aerial of from 75 to 100 feet or longer for halfway decent results.

Not every tube works well in this adapter. Try switching tubes around. You may have to try two or three tubes to find the most sensitive one, and it will be easy to tell which is the right one, by the results which you finally get.

Should you have a broadcast set of less than six tubes, such as a midget set of five or even four tubes, do not expect great results from the loudspeaker. It will be better to use a pair of headphones

(Continued on page 55)

At Last! Oliver Amlie's "DX" Hook-up

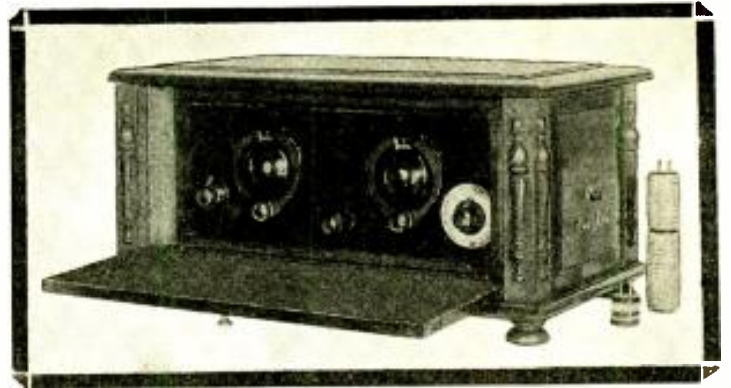

Mr. Amlie's 18 to 900 meter "DX" receiver.

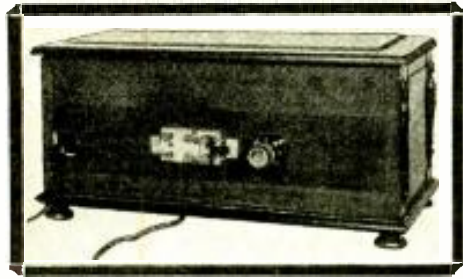

Rear view of the receiver.

OVER 1,600 REQUESTS were received by Mr. Amlie for this circuit! Some time ago we published a letter from Mr. Amlie in our "Among the Hams" Dept. in which Mr. Amlie offered to give us his 'Australia, consistently' receiver circuit, if sufficient interest was shown. Here's the circuit! Mr. Amlie lives in Philadelphia, Pa.

found the best for reception on waves from 18 to 560 meters and a 7 megohm leak for reception on 560 to 1,250 meters. For making the coils, bakelite or fibre tubing may be procured at any radio store, the size being that which will fit snugly over a tube base. Glass tubing could be used.

Parts Needed for Amlie "DX" Receiver

- Symbols*
- 1—5 to 1 Mignon (or other) audio transformer T1
 - 1—All-stage Karas Harmonic (or other) A.F. transformer T2
 - 1—No. 130 "Neutrocap" (or other) R.F. choke 80 henry L3
 - 2—Hammarlund midget conds. 50 mmf. (code mc. 50s) C1-C2
 - 2—David Grimes (or other) .0005 mf., variable condensers L1-L2

THE accompanying diagrams and photos show the circuit used in the long-distance, all-wave receiver which was mentioned some months ago in a letter which appeared in the "Among the Hams" column.

Mr. Amlie has had the distinction of hearing "consistently" VK3ME and other far distant stations, thousands of miles away from his home in Philadelphia, Pa.

The diagrams show the connections of the quite ordinary parts used by Mr. Amlie in making his "DX" receiver, and he gives us herewith the data for winding the coils covering the different wave bands. It must be remembered that a great deal of the success attained with a short wave receiver is to be rightly credited to the use of good quality apparatus, plus the careful installation of all wiring and instruments, plus a great deal of patience.

Mr. Amlie has had nearly 1,700 letters asking for this circuit and we are pleased to present it herewith with his compliments. Mr. Amlie says in his letter, that he will be very glad to hear from those who build this circuit as to what reception results they obtain. His address is 56th City Line Ave., Overbrook, Philadelphia, Pa.

Says Mr. Amlie: "This set will take you up to the 560 and 900 meter bands." He says he has had reports on stations

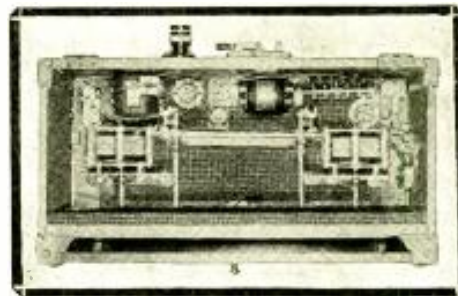

Top view of Mr. Amlie's receiver.

operating on these wave lengths above 550 meters. This set uses but three tubes and Mr. Amlie has heard VK2ME, VK3ME, G5SW, UOR2, for an entire summer, missing no programs, and all on the loud-speaker. European and Australian stations can be heard 20 feet from the loud-speaker.

As one of the drawings show, the two midget condensers, each of 250 mmf., are mounted on an aluminum panel, the two mounting holes for these condensers being drilled 8 inches apart. This aluminum panel supporting the midget condensers is mounted 5½ inches back from the bakelite front panel. The two midget condensers are connected with the control dials by bakelite or even wood extension rods. A 5 megohm grid leak was

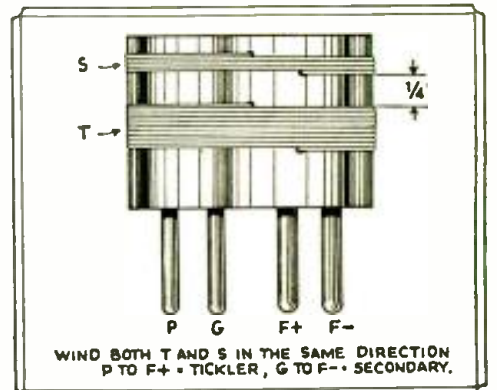

How the Amlie plug-in coils are wound.

- 4—UX tube sockets.
- 1—7 by 10 aluminum panel.
- 2—4½ by 5½ inch aluminum panel for .0005 mf. condensers.
- 1—.00025 mf. Dubilier condenser with grid-leak clips C4
- 1—Grid-leak 5 megohm and one 7 megohm R1
- 1—.0025 mf. Dubilier cond. C5
- 1—Single jack.
- 3—30 ohm rheostats R1, R2, R3
- 2—K-K (or other) 4-inch Vernier pot dials.
- 2—Small dials or knobs for .0005 mf. cond.
- 1—Push-pull switch S5
- 1—Volume control, 10,000 ohms Bradleyohm R4
- 2—012a RCA.
- 1—012a Arcturus tube (amplifier).
- 1—Cabinet.
- 2—Rubber mats or stair mats, 10c "variety" (I used these to line inside of cabinet; optional).

(Continued on page 56)

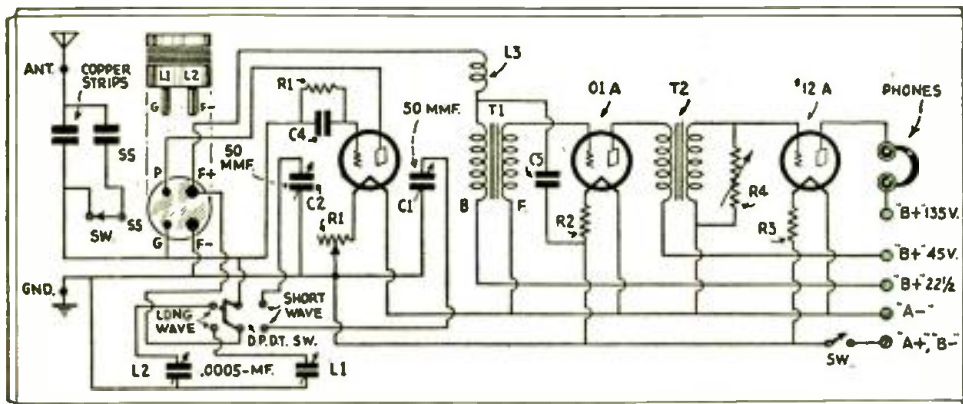

Circuit used by Mr. Amlie in his 18 to 900 meter "DX" receiver.



Announcing the

HONORARY MEMBERS

Dr. Lee de Forest
John L. Reinartz
D. E. Replogle

Hollis Baird
E. T. Somerset
Baron Manfred von Ardenne
Executive Secretary, Hugo Gernsback

WHEN radio was young, and when, as a matter of fact, it was called *wireless*, the writer took it upon himself to organize the world's first radio association or league. This was called the WIRELESS ASSOCIATION OF AMERICA, and was founded by the writer in January, 1909. Dr. Lee de Forest was elected as Honorary President of the association. The purpose of that body was to ward off legislation unfair to the amateur. In 1912 there had been enrolled not less than 22,300 members, and in due time Congress enacted laws which put the radio amateur on the map! In August, 1912, the law known as the *Radio Act of 1912* was put on the statute books. That ended the usefulness of the WIRELESS ASSOCIATION OF AMERICA.

In December, 1912, the writer organized the RADIO LEAGUE OF AMERICA, whose honorary members were such distinguished men as Captain W. H. G. Bullard, U. S. Navy (the first Chairman of the Federal Radio Commission), Dr. Lee de Forest, Nikola Tesla and Prof. Reginald A. Fessenden. The purpose of the RADIO LEAGUE OF AMERICA was of a national emergency character in which transmitting amateurs pledged their stations to the United States Government to be used during the war, our entry into which had been foreshadowed in 1915. Thousands of league members who had enrolled were made use of by the National Government when war finally came, and in many instances their radio equipment was also used, either directly or indirectly. Actually hundreds of

members of the RADIO LEAGUE OF AMERICA served during the war as radio operators in the Army and Navy.

With the ending of the war, the use-

of the organization gave an excellent account of itself both before and during the war.

For many months I have been asked by short wave enthusiasts to form a new league to bring together the large number of short wave men, who at the present time have no organization and who have no standing as a body.

It is true that there exists today an excellent radio league which takes care of the interests of the transmitting amateur, particularly that class of amateurs who transmit CODE.

However, the vast body of young and able men who are interested today in transmitting voice, and the much larger class of receiving short wave amateurs who own no transmitters, have no standing of any kind at present, and it is for them that the new SHORT WAVE LEAGUE has been created.

Purpose of the League

AT the present time, it is believed in many quarters that broadcasting in the future will remain as it is now located, i.e., in the wavebands between 200 and 550 meters. Many observers, including myself, do not share this view. It has been pointed out that with television assured, it will become necessary for broadcasting, sooner or later, to take to the short waves, for technical reasons obvious to most radio engineers. The public must be prepared for the change, which will undoubtedly be gradual, so as not to disrupt the radio sales market.

While a great wave of enthusiasm is now sweeping the world as far as the *short waves* are concerned, there is still a very large public to be educated to the wonders of these interesting waves. It is felt that the SHORT WAVE LEAGUE, through its members, can accomplish a tremendous amount of good in this direction. It is certain that when television finally becomes established in the home it will be done through the instrumentality of short waves. The short wave experimenter, backed by the SHORT WAVE LEAGUE, will be in a position to do much good in this direction also.

The amateur who is *not* interested in code, but who is interested in the transmission of VOICE only, is handicapped by the Radio Act of 1927, which superseded the Radio Act of 1912. You cannot operate a short wave phone transmitter *unless you know the code!* In the opinion of many experimenters—and there are thousands of them—this requirement today does not have the useful need it had years ago. The *phone amateur* believes that this restriction should be removed or at least modified.

This idea at the present time is not a welcome one in many quarters, but the

THE HONORARY MEMBERS

DR. LEE DE FOREST—Needs no introduction to radio men as he is known throughout the world as the inventor of many radio devices, including the three-electrode vacuum tube. He has also done a great deal of work in talking pictures.

JOHN L. REINARTZ—Known to every short wave enthusiast the world over; famous for his articles and circuits used in short wave operations.

D. E. REPLOGLE—Well-known engineer, who has been particularly active in promoting the development of television and many radio devices, including vacuum tubes.

HOLLIS BAIRD—Chief Engineer of the Shortwave & Television Corp., of Boston. Mr. Baird is one of the outstanding American experts in the short wave and television fields.

E. T. SOMERSET—Call G2DT—One of England's outstanding short wave experts, who has contributed extensively both to European and American magazines; numerous articles from his pen having appeared in SHORT WAVE CRAFT.

BARON MANFRED VON ARDENNE—One of Europe's outstanding television inventors and whose "cathode ray" television is practically the only one so far manufactured and demonstrated in actual operation.

fulness of the RADIO LEAGUE OF AMERICA came to an end. The league published an official list of radio amateurs who had enrolled, and all in all it may be said that

SHORT WAVE LEAGUE PLATFORM

- 1.—To help popularize short waves among the public.
- 2.—To assist authorities in the apprehension of criminals and in general crime prevention through the instrumentality of short waves.
- 3.—To demand enactment of new regulations enabling operators of phone transmitters to be licensed without code requirements, below 6 meters.
- 4.—To bring together short wave enthusiasts by promoting comradeship among them.
- 5.—To eliminate man-made static, the greatest enemy of short waves.

SHORT WAVE LEAGUE

great body of aspirants to radio phone transmission believe "that the time is ripe" to make representations to the Federal Radio Commission for the rescinding of the code ruling as thoroughly antiquated and unnecessary! It is felt, and many letters to the writer attest to this, that something should be done about this situation. The SHORT WAVE LEAGUE will, in due time, be in a position to do something constructive about it, irrespective of the opposition it is sure to have in certain quarters.

So that there will be no misunderstanding it should be particularly noted that such lifting of present restrictions should be applicable *only* to the extra-short wave lengths below 6 meters. In other words, in a wave band where there will be little chance of excessive overcrowding. (More particulars on this phase will be found in this month's Editorial.)

Police radio is becoming more important every day. With the present state of lawlessness existing in this country, it is felt that short wave volunteers will be in a most excellent position to cooperate morally and physically with police departments by listening in on police reports and helping the authorities to apprehend criminals. If there were several million short wave fans in this country who listened to all of the police reports, the amount of crime in this country would be cut down tremendously.

At the present time, the police authorities are handicapped because only their own radio-equipped automobiles get the short wave intelligence from headquarters. Quite often the distances are such that a burglar or hold-up man will make a clean get-away before policemen can get to the scene. If a short-wave amateur hears a police call which refers to a burglary or other crime, in his immediate neighborhood, this short wave fan in effect becomes a "policeman", because he can transmit almost immediately to the policeman on the beat the necessary intelligence, or in many cases he can frighten away the criminal himself and thus frustrate a crime about to be committed.

In this respect, the work of the SHORT WAVE LEAGUE will be of tremendous importance, and it will be the purpose of the League to publish in SHORT WAVE CRAFT verified accounts of LEAGUE members who have helped in apprehending criminals. It is perhaps here where the greatest importance of the LEAGUE will come about.

The SHORT WAVE LEAGUE Headquarters is naturally interested only in supervising the workings of its members as far as this is possible. The Home League can only be of help in influencing the various units, and it is felt that this can be done best by helping to bring into life "local chapters".

While in some cases in the smaller communities it may not be possible to have enough members to form a "local club", it is felt in a fair-sized town there should be several local chapters of the SHORT WAVE LEAGUE. For that reason, the name of the parent body has

By HUGO GERNSBACK
Executive Secretary, SHORT WAVE LEAGUE

been made short and has purposely been chosen so that it will lend itself in its association with the various local chapters throughout this country and throughout the world, because the LEAGUE is international in character.

Suppose you live in Smithville. It therefore behooves you to organize the SMITHVILLE SHORT WAVE LEAGUE. It is advisable, and will be required, that local chapters should identify themselves by having the name of their city first and the name of the parent body, SHORT

purely scientific organization. There are no dues or membership fees to be paid. It has been organized under the auspices of the world's outstanding leaders in the short wave field, men who thoroughly endorse the LEAGUE'S principles. It is not a money-making organization, nor is it conducted for profit in any respect.

SHORT WAVE CRAFT has been selected as the LEAGUE'S official organ, as this journal—with the largest circulation of any short wave publication at present—reaches directly or indirectly the majority of short wave fans in this country and abroad.

SHORT WAVE CRAFT will publish the LEAGUE'S news from month to month, thereby keeping up the interest of its members.

The League's Rules

EVERY short wave amateur, experimenter or fan, of good standing, is eligible for membership.

He may be a citizen of the United States or any other country; there are no restrictions as to nationality.

He must own a transmitting set or a receiving set, or both.

A simple blank with rules for the League will be sent to each applicant, which blank he must fill out and return to Headquarters so that the LEAGUE will have a permanent record of all members.

Here Are the Rules of the League

I, *THE undersigned, do hereby apply for membership in the SHORT WAVE LEAGUE upon the express condition that by so doing I do not assume or incur any liabilities, dues, assessments or any financial obligations whatsoever, and if accepted, I do agree to follow and abide by the rules and regulation of the LEAGUE, as set forth herein, and all other rules and regulations which may hereafter be adopted.*

Rule 1.—To observe all rules and regulations of the Radio Act of 1927.

(Continued on page 54)

GET YOUR BUTTON!

The illustration here-with shows the beautiful design of the "Official" Short Wave League button, which is available to everyone who becomes a member of the Short Wave League.



The requirements for joining the League are explained elsewhere in the accompanying article. The button measures 3/4 inch in diameter and is inlaid in enamel—3 colors—red, white, and blue.

WAVE LEAGUE, following it. This will give the local chapter its required standing with the parent body, and will entitle it to listing not only in SHORT WAVE CRAFT but in the regular YEAR-BOOK, which will be published in the future. Articles on how to proceed in forming local chapters will be published in forthcoming issues of SHORT WAVE CRAFT.

The SHORT WAVE LEAGUE was organized at New York under the Laws of the State of New York, in March, 1915. The complete charter will be published in the next issue of SHORT WAVE CRAFT. It may be said here that the LEAGUE is a

Application for Membership
SHORT WAVE LEAGUE

I, **THE UNDERSIGNED**, herewith desire to apply for membership in the SHORT WAVE LEAGUE. I have read all the rules of the LEAGUE, and hereby pledge myself to abide by all the rules and regulations of the SHORT WAVE LEAGUE.

Name

Address

City and State.....

Country

Date.....

(It is important the reverse of this blank be filled out.
No application valid without it.)

FIVE METER PUSH-PULL TRANSMITTER

By E. P. HUFNAGEL, W2BUK, AND G. HERRSCHER, W2APW

A distance of 75 miles has been bridged by phone with a set of this type, using battery tubes.

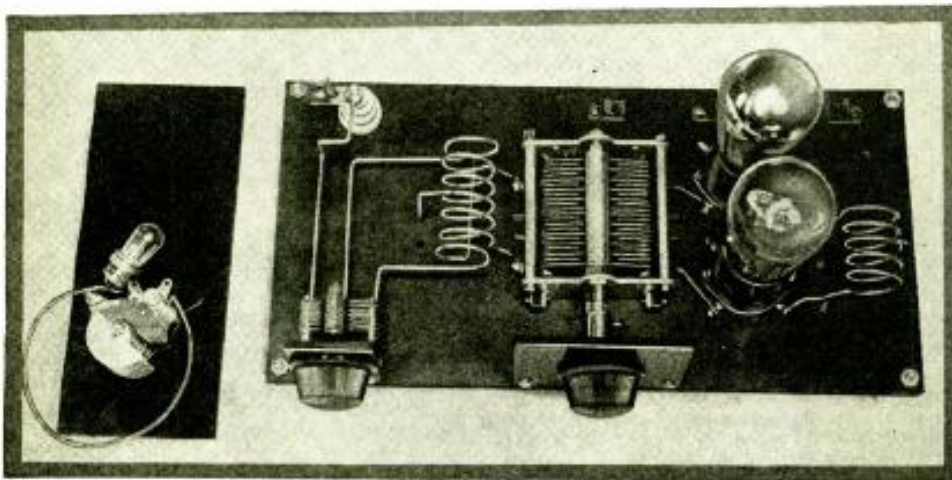

Appearance of the 5-meter P-P transmitter, with simple wavemeter at left.

IN the last issue of SHORT WAVE CRAFT the authors described the construction of a 4 to 7 meter super-regenerative receiver, suitable for receiving short wave phone, code or television signals. There are about fifty licensed amateurs "cutting loose" every day on the new five meter band in Irvington, N. J., one report states. The tuning of either receiver or transmitter is not as critical as might be supposed, and the transmitter here described has

been tried out with very excellent results. It packs a "powerful wallop" and moreover the cost of building it is not beyond the pocketbook of the average amateur. No ground was used in our tests but only a single antenna wire, 8 feet long, connected to the "output" circuit as shown in the diagram. The interest among the Radio Amateur Fraternity in the new five meter band is growing very rapidly and the writers have received numerous letters from those who read the article

last month on the 4 to 7 meter super-regenerative receiver.

Any choice of tubes desired may be used in the transmitter within reason, and in some tests, tubes as small as the '30 type 2-volt tubes were used on dry batteries. In fact in one test a distance of 75 miles was bridged by 'phone, using a transmitter of this type, with '30 tubes with dry cells, the receiver having been described in the last issue of SHORT WAVE CRAFT. One of the interesting things about this five meter transmitter

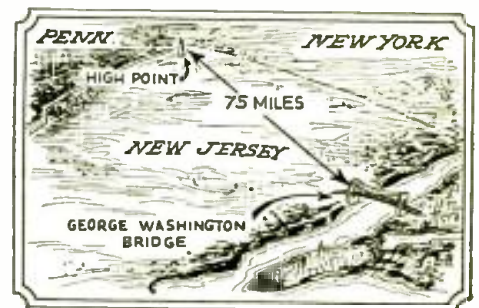

In a recent test reported by the authors and using a transmitter of the type here described, fitted with battery tubes excited by dry batteries, a distance of 75 miles was bridged by phone.

is that the receiver can be located right on the same table, and the "home signal" will only occupy a small space on the dial; the transmitter can be kept going and need not be shut off to listen in therefore.

Transmitters of the five meter type, such as the one here described, are very fascinating and you will be surprised to see how powerfully these transmitters oscillate.

For a wave meter, a simple loop of heavy wire, about No. 14 gauge, coupled to a ¼ or ½ watt neon glow lamp and a midget condenser 100-mmf. capacity was used, and when checking up the circuits the neon lamp glowed as far as five feet away from the transmitter.

A modified tuned-plate, tuned-grid circuit is employed, and specially adapted to a push-pull arrangement. With this circuit no grid or plate blocking condensers are necessary. Note that the connections to both coils, L2 and L3 must be made in the exact electrical center of the windings. The entire transmitter should be built first, and these two center tap leads left off. Then by using flexible leads, you can temporarily attach these

(REVERSE SIDE)

I consider myself belonging to the following class: (Put X in correct square.)

- Short Wave Experimenter
- Short Wave Fan
- Radio Engineer
- Student

I own the following radio equipment:

- Transmitting.....Call Letters.....
- Receiving.....

two leads at approximately the electrical center, and by using a sensitive neon bulb, such as the 1/4 or 1/2 watt size, it can readily be determined how accurate you were. Set condenser C3 at nearly minimum capacity, hold neon bulb at the end of L2, and vary the capacity of C2 until the neon bulb lights up to maximum brilliancy. At this point, the set is oscillating properly; the neon bulb should fail to light if it is touched to the center connections of L2 or L3; if the bulb should light, change the center connection until the bulb fails to glow.

The above instructions for adjusting the transmitter hold true with any type of tubes used, and we have tried most of them. All present type tubes we found to oscillate readily on five meters. Two UX '30's with 2 dry cells and 135 volts of "B" batteries make an excellent low-power transmitter; 2 UX '33's with the same batteries give slightly more power output. Two UX '71-A's with a storage battery and a "B" eliminator can put a strong signal as far as 20 miles. Two UX '45's or two '47's (pentodes) run entirely from A.C., without the use of "B" batteries, will produce 10 watts of power in an 8 foot antenna. Two UX '10's with as high as 600 volts on the plate is "high power" on these frequencies. To adapt the circuit for use with pentodes the only change from the present set is the change from 4 prong to 5 prong sockets and the application of voltage to the pentode screen grids.

An antenna 8 feet long has a resonant frequency within the amateur five meter band. By tuning the condenser C1, until the circuit C1-L1 is in resonance and tapping the antenna on the "live" end of the

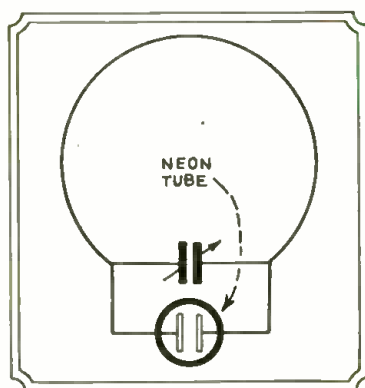
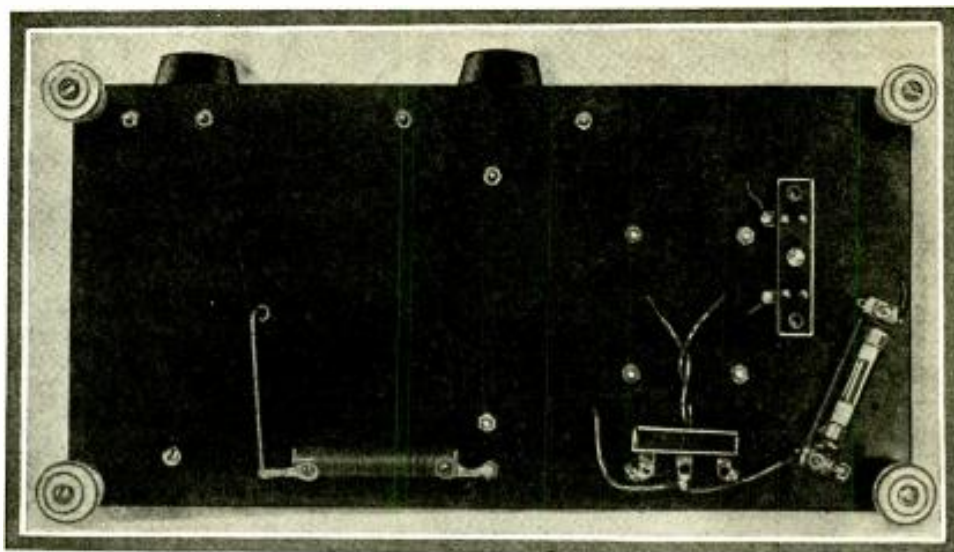

- R1 75 ohm center-tapped resistance.
- R2 Grid leak.
 - For use with 2-'10's—10,000 ohms.
 - For use with 2-'12-A's—15,000 ohms.
 - For use with 2-'45's—50,000 ohms.
 - For use with 2-'47's—25,000 ohms.
 - For use with 2-'71-A's—10,000 ohms.

- Mounting base 7 x 12-inch hard rubber panel.
- 5 Fahnestock clips.
- 2 Small hard rubber panels for mounting condensers.
- 5 Porcelain mounting insulators.
- 2 UX sockets.
- Miscellaneous mounting angles and hardware.

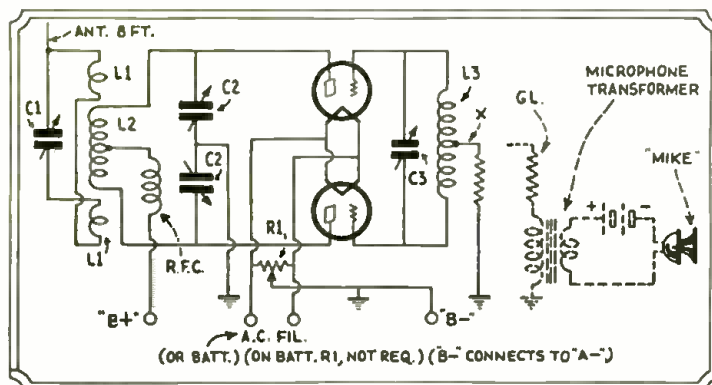

Photo at top—shows bottom view of 5-meter push-pull transmitter.

Directly above, the simple wavemeter circuit used by the authors. A neon tube indicates the resonance point.

Left: Complete circuit of 5-meter 'phone transmitter. "GL" connects at point "X" for phone modulation.

TOURMALINE CONTROL FOR ULTRA-SHORT-WAVE TRANSMITTERS

Zeiss, of Jena, recently has put on the market crystals of tourmaline, which serve to keep perfectly constant the frequency of a transmitter or other oscillator, in the same way that quartz crystals have long done. Tourmaline is a mineral which crystallizes in the hexagonal system (rhombohedral). Hitherto it has been used chiefly for the production of polarized light and to demonstrate the same (tourmaline "tongs"). But now it has become known that tourmaline also shows piezo-electric properties, expanding or contracting mechanically under the influence of electric forces. While tourmaline on wavelengths of more than 40 meters has, compared with quartz, only the advantage of greater stoutness, the matter is very different below 40 meters. Quartz crystals are made commercially only down to some 40 meters wavelength; since they then soon become unworkable on account of the slight thickness of less than 0.4 of a millimeter (.016 inch). Now tourmaline crystals are usable for the direct control of oscillators down to wavelengths of 2 meters (6.56 ft.). Also they stand loads of 20 watts and more easily; because then simply larger tourmalines are used. Here, at last, a means has been found of producing the ultra-short waves, which are gaining more and more importance in modern radio technology, by direct crystal control with the vitally needed constancy, without having to follow the indirect ways involving so much trouble.

condenser, determined by means of a neon bulb, power should be transferred to the antenna; current in the antenna can be indicated by means of a 6 volt pilot lamp placed in the center of the 8 foot antenna (i.e., 4 feet from the end). Antenna current will be highest when both grid, plate and antenna circuits are in resonance with the antenna.

Operating Hints

Condenser C2 should be of good construction. Two Pilot J13 condensers may be used, if the power does not exceed that developed by two '71-A's.

For phone transmission the set may be modulated by Heising modulation.

Note that both tubes should be matched as perfectly as possible by checking up on a tube tester, or else buying them matched; otherwise they will produce two waves of differing frequency, due to the different internal capacities of each tube.

Center tap resistance R1 is not neces-

sary when batteries are used, B- can then be connected to A- instead.

The grid leak should be of a non-inductive type unless the center connection is in the exact electrical center, or a radio frequency choke (RFC) is used between the coil and the grid leak.

Five meters is easy to work with, but it is best to remember that only the best quality parts should be used.

Inferior tubes burn up rapidly under the high frequency strain; good tubes prove themselves by standing up under the strain.

List of Parts

- C1 50 MMF. midget condenser.
- C2-C2 Split stator Cardwell type 412B; 50 MMF. per section.
- C3 30 MMF. grid adjuster condenser.
- L1 1 turn No. 14 buss (copper) wire, each end of L2, 1-inch diameter.
- L2-L3 5 turns No. 14 buss wire 1-inch diameter.
- RFC 36 turns No. 30 S.S.C. wire, space wound on 3/8-inch tubing.

RADIO GHOST

By DR. F. WOLF

Instructor, Technische Hochschule, Danzig

The short wave echo DOES come from space! New demonstrations by theory and observation!

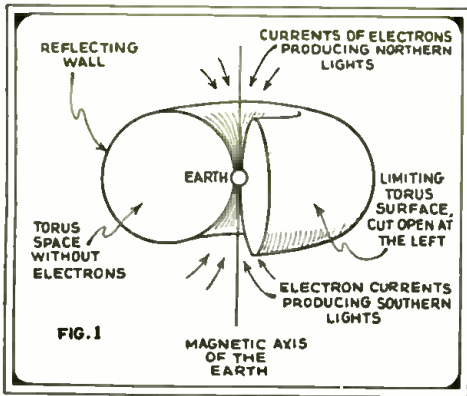

Fig. 1—The torus surface about the earth, which the electrons cannot penetrate.

A BRIEF account has been given before in *Die Umschau*, of the surprisingly "delayed echo" of short radio waves, which had been observed by the Norwegian scientist C. Störmer, and his co-worker the engineer J. Hals. For explanation Störmer first assumed that waves which go out into space from our transmitting stations are occasionally reflected back by swarms of electrons speeding along far out there, only to be heard in the receiver late, as an echo, when the signal arriving by the direct route has already long since died away. However attractive Störmer's attempt at an explanation sounded it nevertheless appeared very venturesome.

Do we then know whether the radio waves are capable of penetrating the Heaviside layer of the upper atmosphere and getting out into space at all, so that such a reflection far outside is at all possible? Do we know whether in the case of such a process, the energy is not far too much weakened for the reflected waves to be demonstrable at all on their return to the earth?

A Puzzling Phenomena

The lateness of the arrival of this echo after the direct signal of the Dutch short wave station Eindhoven was observed by the Norwegians, and was indeed surprisingly great in Eindhoven itself. Waves which go once around the entire earth require for this excursion only about a seventh of a second like light. This sort of echo has been long familiar and was also being observed at the time; but likewise there occurred other distinct echoes, which arrived rather irregularly three or more seconds, sometimes even as late as half a minute, after the direct signal. Even two seconds would suffice to let a radio signal go almost from the earth to the moon and return again. Yet was it really necessary to call on interstellar space for the explanation? Manfred von Ardenne, Appleton, and Van der Pol, the conductor of the Eindhoven station itself, mentioned other possibilities of explaining the puzzle. Every radio amateur knows about the fading effect, whose interpretation is connected with the undoubtedly occurring reflection of the waves from the ionized upper strata of air, the so-called Heaviside layer. Even in the case of the Störmer echo a part of the waves might be reflected around the earth a number of times on this layer, until finally after a large number of revolutions it is again cast down to

the "listening station" and the echo is produced.

The absolute lack of regularity with which the echoes arrive, would make it possible to fit the phenomena to this interpretation. Or else continual reflections might take place between the Heaviside layer and the surface of the earth, so that a rather slight number of revo-

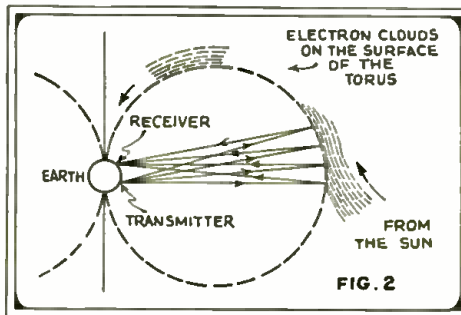

Fig. 2—Reflection of radio waves on electron clouds.

lutions of the waves about the earth would suffice for explaining the great delays. Finally it was thought that the so-called "group velocity" of the radio waves might be so far reduced by the great density of electric charges in the ionized strata of air, that this would cause the great time intervals between the arrival of the waves arriving directly and that of those coming circuitously.

Wavelengths That Penetrate Heaviside Layer

For some time the two theories puzzled us: According to one view the waves were supposed to suffer their great retardation *within the earth's atmosphere*, while according to Störmer they were supposed to be reflected *far out in space* and only then did they come back again to us. Who was right?

The difficult decision we owe to a detailed mathematical investigation on the part of the Danish scientist, P. O. Peder-

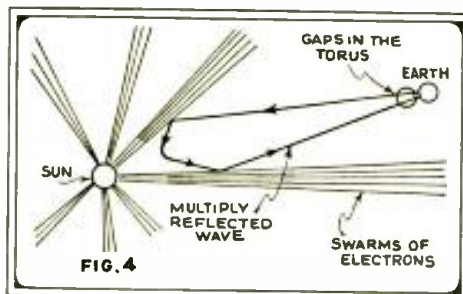

Fig. 4—Possible wave reflection at a great distance from the earth.

sen, who already in 1927 summarized all our theoretical and experimental knowledge of the transmission of radio waves in an impressive work, and is therefore extraordinarily familiar with this field.

Recently Pedersen, with all the means available today, has made calculations regarding the above-mentioned possibilities of the course of the waves within the atmosphere and he arrives, in all three cases, at the same unambiguous conclusion: waves which would have to travel such great distances within the atmosphere, and in part in its ionized strata, would have entirely lost their energy long before they reached the goal. In this way, accordingly, the origin of the echo can have no scientific basis. On the other hand, on the basis of experiments, Pedersen succeeded in proving conclusively, with regard to the reflection of short waves on the Heaviside layer, that at night waves of less than 70 meters, and all waves shorter than 40 meters at any time of day, *can penetrate through the ionized upper strata of air into space*. The wave length in the case of the Eindhoven experiments is 31.6 meters.

The Correct Explanation of "Echoes"

It is therefore necessary, after all, to consider as correct the unique and interesting Störmer explanation of the

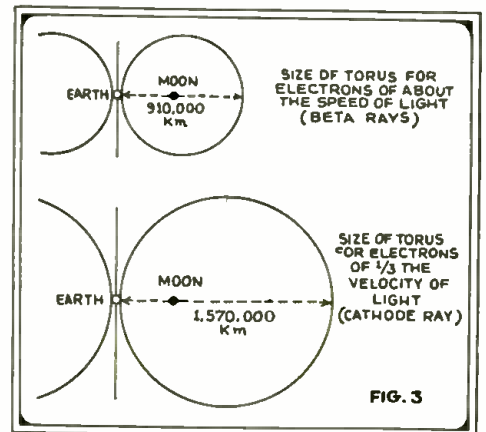

Fig. 3—Size of the torus in the case of different electron velocities.

"echo phenomena". There seems to be a connection with the "polar lights". These remarkable light phenomena are apparently caused by very rapidly moving electrons—tiny particles of negative electricity—which leave the sun and penetrate our atmosphere. There they collide with the molecules of the air and thereby produce the well-known illumination—auroral lights. Similar processes also occur in glow lamps and Geissler

(Continued on page 50)



How to erect a "vertical" aerial on an apartment house.

SIMPLE VERTICAL S-W AERIALS

That
Bring in Stronger
Signals With Less
Fading



"Vertical" aerials can often be advantageously hung from a tree.

MOST short-wave enthusiasts use, for short-wave reception, their regular 200-550-meter broadcast antennas usually of the long horizontal type with a vertical lead-in. Their short-wave reception also is often marked by fading.

"While short waves may inherently fade some," states Hollis Baird, chief engineer of the Shortwave and Television Corporation, "actually much of this is due to the receiving antenna used."

"Vertical antennas are now being erected by leading broadcast stations for transmitting purposes. This same antenna is the kind that should be used for eliminating much of the fading now experienced on short waves and even on broadcast waves.

"Incidentally, the vertical antenna makes for a much neater looking job on any house and in many instances makes the erection of an antenna simpler; since the long stretch of the ordinary flat-top demands two points of suspension, well apart, with resulting guying and usually a bad sag, which tends to swing in a high wind, and in so doing, does not aid reception by any means.

"A vertical antenna is practically the present lead-in. It should be kept a couple of feet away from any structure if possible. In order to obtain this it may slope a bit upward and be connected to a short cross-wire running from a tree to the house, care being taken, however, that the vertical portion be completely insulated from the flat-top portion, which becomes merely a supporting wire for the vertical antenna.



A rope or wire supporting "insulated" vertical antenna.



Another happy idea—fasten the vertical antenna to the side of a chimney, supporting the aerial wire on insulators, of course.

"Apartment houses are particularly desirable locations for vertical antennas since, if many flat tops are attempted, the roof becomes a maze of cross wires; and one invariably breaks and falls across the rest, shorting them out and ruining reception. The vertical antenna in this instance can run from the apartment up to the roof, being held off from the building by a one- or two-foot stick, preferably the latter, at either end.

"This applies to the lower apartments. Upper apartments, with only a few feet to the roof, may erect a short pole at the edge of the roof and get extra height by dropping the vertical antenna from the top of the pole to a short stick at right angles to the building extending outward from the window sill.

"On a single house the chimney is usually the logical place to use for supporting a vertical antenna, but the window through which the antenna comes into the living room is usually some feet from the chimney. In this case the vertical antenna should be erected up the side of the chimney, but held off as in the case of the apartment house wall; and then a short wire should be run from it at the bottom over to the window through which the antenna ordinarily enters.

"All radio listeners changing over to this type of antenna should find improved reception from a fading viewpoint; and, when listening-in on short waves, particularly marked improvement in reducing the effect of fading should be experienced."

More About the "Midwest" Converter

(Concluded from last issue)

Sets Should Be "Air-Tested"

It is always interesting to know that a set has been "air-tested" before it is shipped from the factory, but a little consideration would show that such an air test on B.C. band sets could mean nothing with the work being done in the daylight and only "local" stations coming through. With the short wave converter it is entirely possible to test "on the air" and receive real DX.

However, this test is not universal. Only a few points on the dial can be covered. In order that the final tester may know that the set is good on all points he must make gain tests on at least six points on the dial.

It is also necessary to know that the oscillator is behaving correctly at these high frequencies and that it is not generating an audio component in itself. The test previously described using a tuned radio frequency receiver tuned to the

converter's oscillator, will establish the fact that the oscillator is quiet and working.

The customary gain tests can easily be made with an oscillator that covers only the first point on the switch. The other points may easily be tested by harmonics generated by this same oscillator.

It is necessary to know that the i.f. transformer can be adjusted accurately to the nominal frequency of 575 kilocycles, and that it may also be adjusted to 540 and intermediate points. This is best done by means of an oscillator tuned to these frequencies. The energy is fed into the grid of the first detector and the output is fed to a typical broadcast set. The procedure is simple in practice and very fast.

Test for "Microphonics"

The test for microphonics is very necessary, even though the condenser be mounted in rubber and the dial attached

only to the variable condenser and not touching the chassis at any point; even though the variable condenser be widely spaced, sturdily constructed, and specially designed to eliminate microphonics, yet certain resonances may coincide and "howling" would result. If the board upon which the loud-speaker is mounted should be tuned to the same frequency as one of the plates in the variable condenser, strong signals when weakly modulated would produce a resonant howl and nothing would back this up except the loading of the plate or the loading of the panel.

This test for microphonics cannot include a cabinet if the shipment is to be made "chassis only." If a complete shipment is to be made this test is as follows: A short wave oscillator is set up and modulated with a variable audio oscillator of the beat frequency type. The

(Continued on page 55)

HOW "TE-KA-DE" .4 INCH WAVE TRANSMITTER and RECEIVER Bridged 2/3 Mile

By DR. F. NOACK

Berlin-Schlachtensee

Speech has actually been carried two-thirds of a mile on .4 inch (1C.M.) waves. The details of the 1 C.M. transmitter and receiver are here given by Dr. Noack. The apparatus described has been built and tested by a prominent German concern.

DR. KOHL, instructor at the University of Erlangen, together with the South German Telephone, Cable and Wire Company (TE-KA-DE) of Nuremberg, has made a transmitter and receiver for one-centimeter (0.39 inch) wave experiments, with which it has been possible to bridge distances up to 1000 meters (3,280 ft.) with the use of small mirrors.

It is well known that there are great difficulties in producing one-centimeter (0.39 inch) waves with "feed-back" or regenerative detectors; because in general the A.C. potential conducted to the grid, because of the small inductance, is not sufficient to produce oscillations, and because the electron velocity is, in general, too low for the high frequencies. Therefore Dr. Kohl makes use of the Barkhausen-Kurz circuit. For this hook-up, as a matter of principle, ordinary amplifier tubes can be used as oscillators. Yet Dr. Kohl had *Tekade* manufacture a special tube, which also has a plate, a grid, and a filament, but with leads and individual metal parts in the tube better suited to the production of one-centimeter waves.

How 1 Cm. Transmitter Works

The Barkhausen-Kurz transmitter operates in such a way that the grid is given a very high positive potential (as regards the filament) and the plate is given a negative potential (as regards the grid). In this case the electrons do not, as in the ordinary oscillators, simply fly from the filament to the plate; but instead, the electrons perform "pendulum or to-and-fro oscillations" about the grid. In general the electrons have different velocities; the slower electrons are caught up by the thin grid wires and produce

of these electrons again get through the grid to the cathode side. Gradually there begins a regular oscillation back and forth of the electrons about the grid. Now the electrons, in the period of their oscillations, induce positive charges on the neighboring grid connections and, as a counter-action, repel negative charges into the wires connected to the grid. *With every motion back and forth of the electron swarm, an oscillation is therefore induced.*

What Determines Wavelength

The frequency of the induced current is accordingly twice as great as the frequency of the electron oscillations. If one joins to the plate and also to the cathode, in each case, a piece of wire one-fourth the wavelength long, then one piece of wire serves as an *aerial* and the other as a *counterpoise*. To be sure, the wavelength produced by the tube is not determined by the length of the wires, but by the potentials applied at the grid or plate. Therefore, if one wishes to change the wavelength, one must change the potentials and at the same time the aerial and counterpoise. From these considerations there have now resulted the *Tekade* U.S.-W. transmitter and receiver.

The transmitter has both the actual transmitter tube R2 and an amplifier tube R1, if one would like to do telephoning or teletyping. On account of the extraordinarily difficult tuning, it is better not to work with C.W. telegraphy, but to conduct a modulated plate potential to transmitter tube R2 via amplifier R1.

Heater and Plate Voltages

The amplifier R1 and the transmitter tube R2 are heated with 4 volts (*in the German set; other tubes will use voltages, of course, which are specified for them*). The heating is regulated by a 3-ohm series resistor W4. Through resistors W2 or W1, as the case may be, the amplifier tube R1 gets a plate potential of 125 volts (approx.), the transmitter tube a positive grid potential of about 250 volts, and a plate potential of about minus 40 volts. Since both these potentials must be quite exactly adjusted, both resistors W1 and W2 have sliders; each is of 3600 ohms. The D.C. potential applied to both is 250 volts. In the grid circuit of transmitter R2 is also a milliammeter (MA), with which we adjust the grid current to 30 to 40 milliamperes.

It is important that, over the plate and grid lead wires of the transmitter tube, we place a sheath of metal, insulated and common to the two wires. The point where the sheath is to be put is to be found by trial. The sheet has to replace a plate and a grid choke, and prevent oscillations getting from the plate and grid into the battery wires. The points where the sheaths are to be inserted are marked "B" in the illustrations. It is to be noticed that the transformer between the two tubes is to have a ratio of about 1 to 4, and that the transformer ahead of tube 1 is to have a ratio of about 1 to 10. To be able to regulate the input tube 1, it is practical to shunt across the input side of the transformer a 12,000-ohm potentiometer.

Details of .39 Inch Wave Receiver

The receiver tube is connected in similar fashion to the transmitter tube. Through a voltage divider of 3,600 ohms (W1) a very high positive potential is impressed on the grid, likewise through a milliammeter. The plate on the other hand gets, via a potentiometer W2 (500 ohms), a potential of only two volts. The filament current of the tube is likewise adjusted by a resistance W3. In the plate circuit of the tube is a transformer, whose secondary is connected through a volume control W4, of 12,000 ohms, to an A.F. amplifier. The tube operates as a rectifier. The points marked "E" are to be grounded carefully.

Parabolic Mirror Reflectors Used

One can place the transmitting and receiving tubes each directly in the focus of a parabolic mirror. Special antenna or counterpoise wires are then not neces-

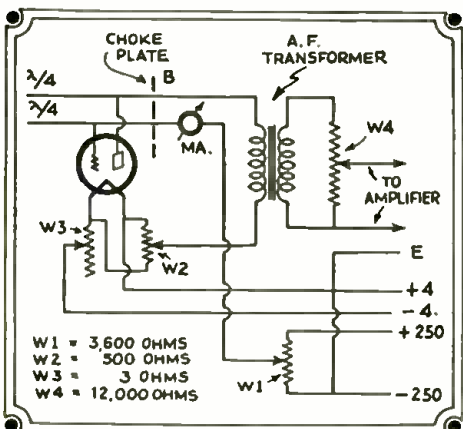

The 1 centimeter (.4 inch) receiver hook-up; the signal, after detection, is passed into the usual A.F. amplifier. The wire "E" is "grounded".

the grid current, which does not take part in the production of oscillations. On the other hand, the faster electrons will get through the grid openings and thus come to the negative plate. The negative plate, however, hurls the electrons back again toward the grid. Some

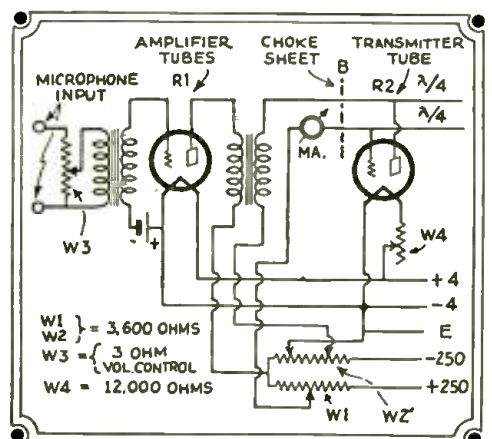

Here's the .4 inch transmitter; R2 is the main transmitting tube, and R1 an amplifier for the voice currents. Phone works better than C.W. code.

sary. If one wishes to bridge "great distances," then a sharp alignment of the mirrors is requisite.

The tone which can be attained with the sets is very excellent. On account of the ultra-short waves obtainable, all such experiments as reflection, refraction,

(Continued on page 54)

The Blanchard S-W Converter

This converter enables you to hear the "police" and other short wave phone signals on your broadcast receiver. It is at once simple and cheap to build.

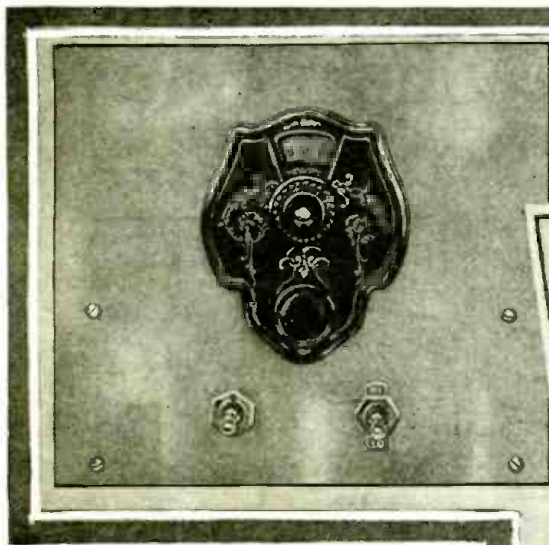

Above—Front view of the Blanchard short wave converter, the "out-put" of which is connected to the "aerial" and "ground" post of the broadcast receiver. "Hi" and "Lo" switch at the right gives two-band control.

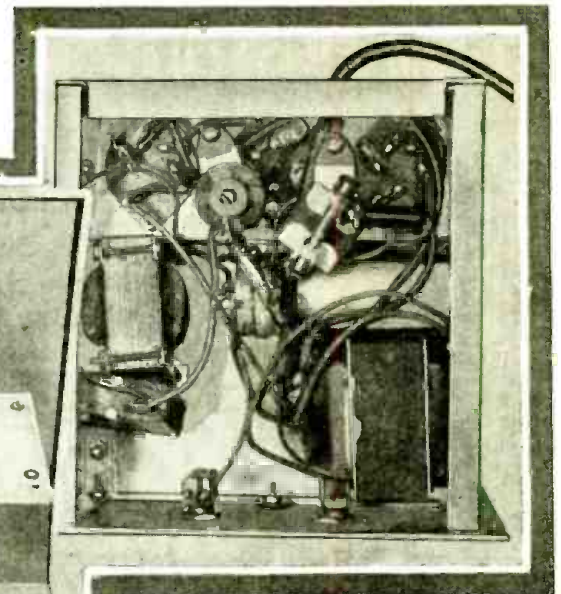
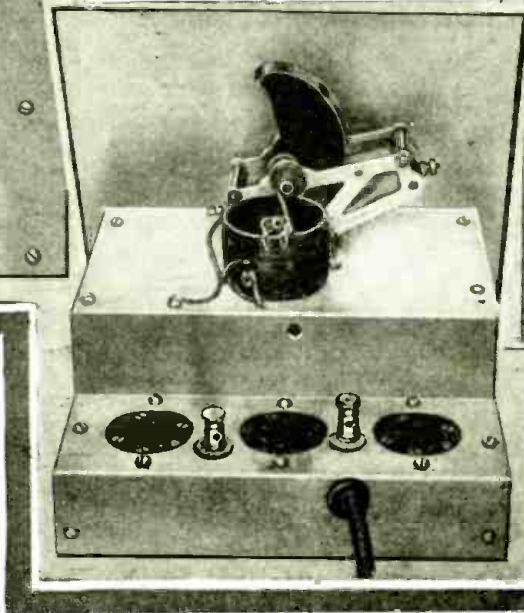

Above—Bottom view of the Blanchard short wave converter. Center photo shows rear view of converter.

THE converter here illustrated was built by Mr. Thomas A. Blanchard, of Reading, Pa., and it has a number of novel features that will appeal to the short wave "fan". By means

tested by one of the editors in conjunction with a screen-grid T.R.F. broadcast receiver and it worked very smoothly; in this test, the aluminum chassis was connected by a wire to the "ground post" of the broadcast receiver. The regular aerial lead-in wire was disconnected from its post on the "BC" receiver and was connected to the antenna post on the "converter." The tuning was smooth and the broadcast receiver dial was set to about 230 meters, but the best point at which to set the broadcast dial will be quickly found by simultaneously ad-

justing the converter and the broadcast dials until a station is heard. The specially wound coil consists of a bakelite tube, 1 1/4 inches in diameter, on which are wound the coils L1 and L11 comprising 10 turns of No. 28 enameled wire (tapped at the 6th and 8th turns as shown in the diagram), and 8 turns of No. 28 wire in the coil L11, which is wound on the same tube and placed about 1/4 inch from the end of coil 1, instead of being adjacent to L11 as indicated in the diagram.

The plate supply can be taken direct from the 110 volt circuit, passing the current through the rectifier tube. As to the detector, the usual .00025 mf. grid condenser and 2 to 4 megohm leak are used.

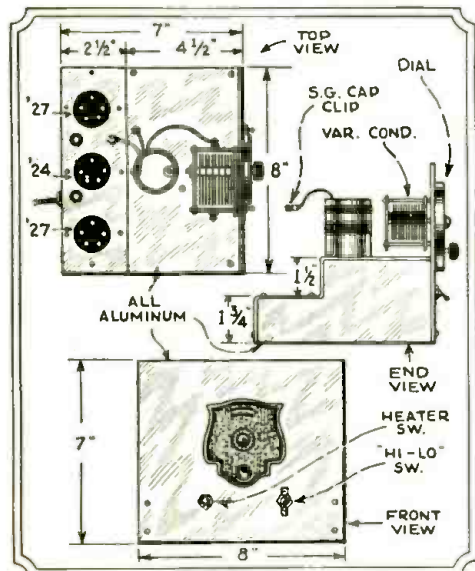

Top, side and front profiles of the short wave converter, with dimensions of the aluminum frame. The aerial and output posts are shown between the tube sockets and the ground connection is made from the chassis to the "ground" post on the broadcast receiver. Wiring diagram of the converter is shown at the right. The coil L111 should be placed above or beside L1, and 1/4 inch from it, all on the same tube.

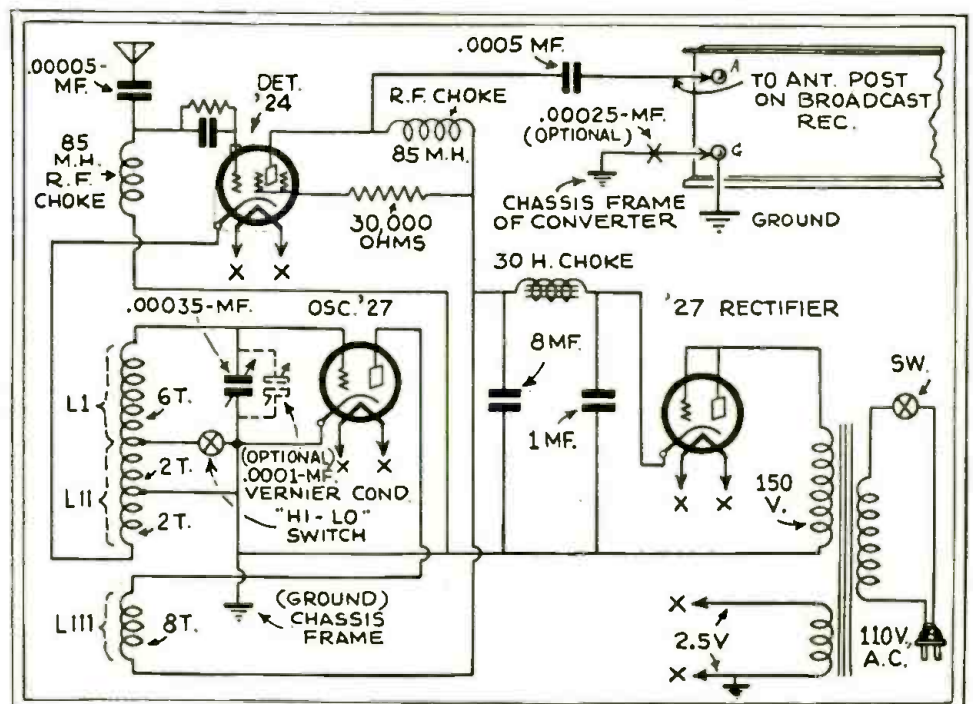

of a switch as shown in the diagram, Mr. Blanchard has arranged the circuit so that two different short wave "bands" may be tuned in without the use of "plug-in" coils. This converter was

ULTRA SHORT WAVES

Experiments With Ultra Short Waves

By ROBERT KRATZENSTEIN

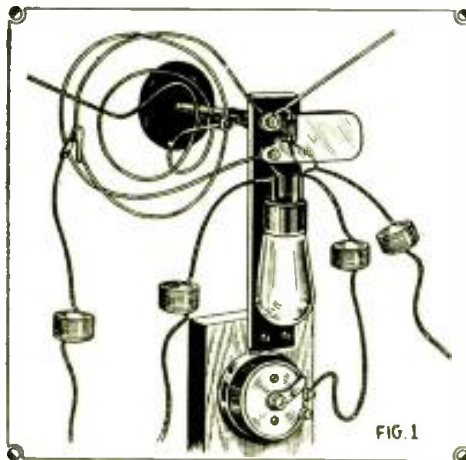

Construction of the first oscillation generator.

Ultra short waves are just beginning to fascinate the American experimenter. Here's some useful data on the results obtained by a German investigator of note. Waves of 3 to 10 meters were used by Mr. Kratzenstein.

quency adjusted for; because otherwise no oscillations occur, and one does not know what the trouble is. Finally I succeeded in producing oscillations even with the slight plate potential of 35 volts.

The construction of the oscillation producer, as used by the author for the first experiments, is shown in Fig. 1. On a vertical strip of bakelite the tube was fastened with the contact pins upward.

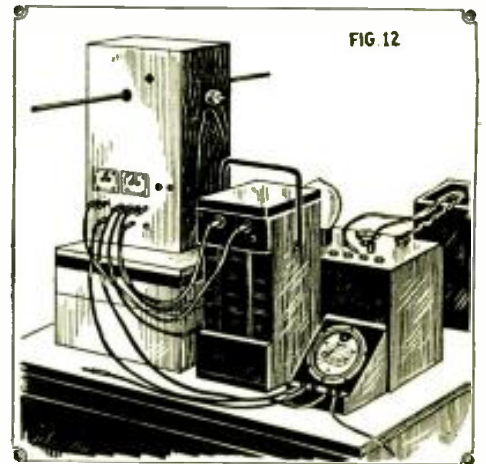

U.-S.-W. oscillation producer, outside view.

ULTRA-SHORT waves form a separate chapter in radio technology, and an especially interesting one. Probably even today we cannot fully see what various purposes ultra-short waves will serve in the future; that they will be of practical importance, is not a matter of doubt. I should be pleased if I could contribute a trifle to the development of technology by presenting here my experimental results concerning the production and reception of these waves.

1—Oscillation Producer and Regenerative Audion

The experiments I began as early as 1926 and continued them in the following years; often, however, with lengthy interruptions. As a tube I used an (German) ultra-tube U-110 and tried it out until oscillation set in. At first this was not so easy to attain, because I did not know either the dimensions of the oscillating circuit or the number of turns of the choke. With tubes which can furnish only a little energy, it is in fact a question of having excellent choking action between tube and battery for the fre-

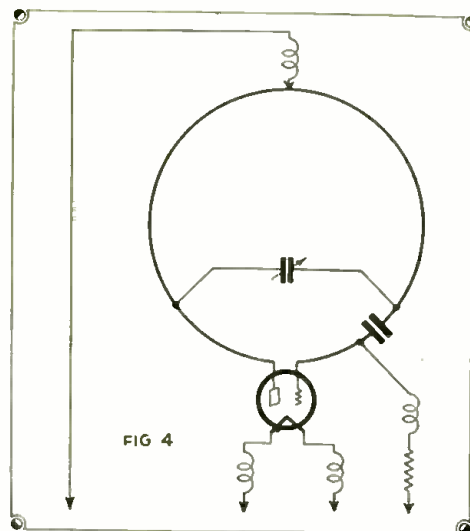

Ultra-audion hook-up for ultra short waves.

Above it was a variable condenser consisting of two plates of the same shape, as will be shown later. The two terminals of the coil were fastened directly to those of the condenser. The chokes, "floating in the air," are small core-less cylindrical coils of 0.5 mm. (No. 24) copper wire (with double cotton insulation) with 16 turns, 1 inch in diameter. The individual turns are fastened together by linen threads. Thus, by way of experiment, a whole series of choke coils was made with different numbers of turns, in order to find the most suitable; this is when the choke is in resonance with the wavelength in question. It is not hard to find the "resonance choke", after one once has oscillations set up. Each of the chokes to be tested is brought near the oscillating circuit, while the plate current of the tube is observed on the milliammeter; that choke which most

nearly approaches resonance tuning, at the furthest distance from the oscillation circuit (in the line of the coil axis) still exerts an influence on the plate current.

Inside the coil one sees in the photograph another smaller coil; this is the coupling coil of the antenna, which is hung up on the two equally large horizontal antenna wires. The hook-up is shown in Fig. 2a. The heating of the tube was done by a storage battery, but the plate current was taken from the D.C. lighting system; and from a buzzer, audio-frequency alternating current was conducted to the grid, with the intermediate connection of an audio frequency transformer. There first served as receiver a crystal hook-up, the photograph of which appears in Fig. 3.

The arrangement of the tuned circuit is the same as with the tube. Crystal reception (galena detector) was possible only within a few meters of the transmitter producer, even with antennas. The wavelength, between 5 and 10 meters, estimated by the length of a resonant

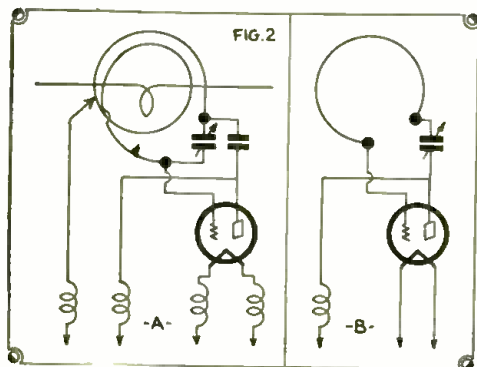

Hook-up of the first oscillation producer.

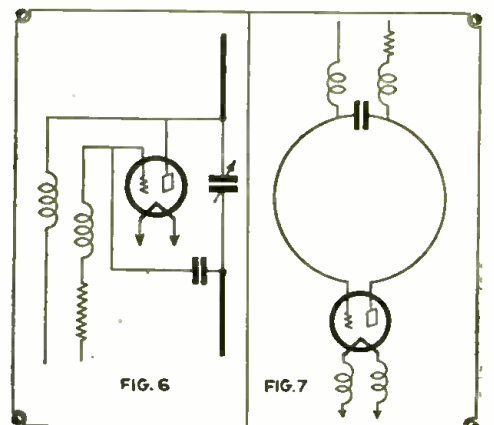

Fig. 6—Tube with open oscillation circuit. Fig. 7—Oscillator hook-up.

dipole, or by the antenna with coupling coil. I had in mind shortening the wavelength as much as possible by using smaller coils and chokes. I also changed the hook-up somewhat by putting the coil (first two windings, then one) and the tuning condenser in series, instead of in parallel (Fig. 2b), whereby I was able to lower the wave to about 3 meters. The condenser had to be on the plate side, otherwise there were no oscillations. The plate current of the tube amounted to 3 milliamperes when oscillating, and 6 milliamperes with the oscillation suppressed.

Now I built a regenerative detector with an unsocketed tube (U 2A) and used, as always, an ultra-audion hook-up (Fig. 4). For the ultra-audion and its variants proved the only serviceable regenerative hook-ups for ultra-short waves. From now on I always used coils with only one winding.

In Fig. 4 are also indicated the positions of the parts, particularly the plate lead, running down symmetrically to the center of the coil. As a tuning condenser I used one with circular plates 11 mm. (.44 inch) in diameter, one of which was fastened at the end of a screw spindle. The distance between the plates could therefore be changed by turning the knob, this changing the capacity also. The tuning curve was logarithmic (Fig. 5). Adjusting the feed-back coupling could easily be done by roughly changing the plate potential a few volts. Later I regulated the plate potential delicately by a variable resistor, which should have a value of at least 5,000 ohms.

In the search for other and perhaps better hook-ups I also tried to bring in to oscillation a tube with open oscillatory circuit; e.g., letting it operate directly on a dipolar antenna (Fig. 6); but with this I had no success. Oscillations were produced only if the two antenna wires were laid nearly parallel (each one meter

its terminals was only 1 cm. (0.4 inch). It was composed of leaves of mica and tinfoil, and its capacity was about 100-nmf. A perceptible increase in damping was not observed through the addition of this condenser. For oscillators and small transmitters this might be the most advantageous "one-tube" hook-up; because the grid and plate current leads (to the tube) lie in the neutral zone (free of R.F. potential, and therefore not sensitive to the hand), which is approximately at the dividing point of the coil. If one, on the other hand, runs a lead directly to the grid then, in spite of the choke coil, a small part of the oscillation energy is lost.

Push-pull hook-ups, which I now tested, offer an advantage in so far as it is not a question of good "choking"; indeed, the chokes can often be entirely done away with. Figs. 8, 9, and 10 show some "tested" push-pull hook-ups; these work about equally well as oscillation producers, and they obviously can just as well be used as detectors, with the addition of grid condenser and grid-leak.

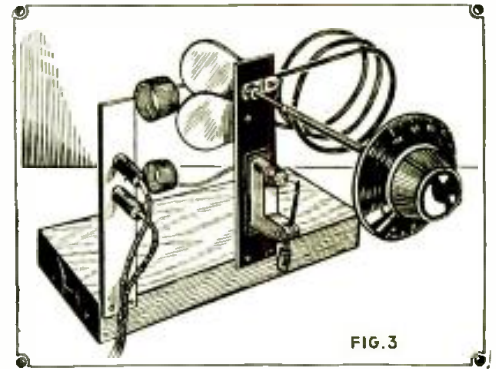

FIG. 3
Crystal detector and receiver for ultra short waves.

direction of winding). This can also be performed experimentally; in which case oscillation again sets in after the coil is reversed. The strength of the oscillations hardly changed, whether the hook-up of Fig. 10 had the grid winding made smaller and the plate winding made correspondingly larger, or vice versa. What form is given the shape of the coil (circular, rectangular or oval) is without importance for the production of oscillations and for reception. This holds not only for this hook-up but also for the others. Thickness of wire and material of the coils also exert only a slight influence; at any rate, one hardly notices any difference, if one observes the plate current milliammeter.

But for another reason one cannot use thin wire for the coil, because then the coil trembles with slight vibrations, which produces very disturbing frequency fluctuations. According to my observations, the lowest wavelength with push-pull hook-ups can be obtained with No. 10. Regarding the positions of the choke coils, it remains to be said that their axial directions are to lie as nearly as possible perpendicular to the lines of

(Continued on page 46)

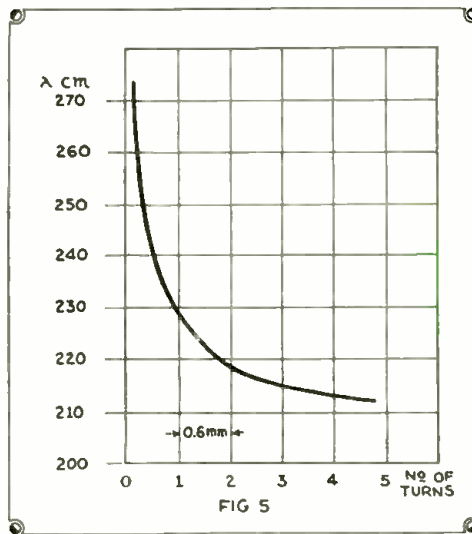

FIG 5

Above, Fig. 5, tuning curve of the "screw" rotary condenser, the wave length in cm's. being given at the left of the graph.

← Push-pull hook-up I, for ultra short wave sets.

→ Hook-up of the oscillation producer, showing plate current taken from 220-volt D.C. mains.

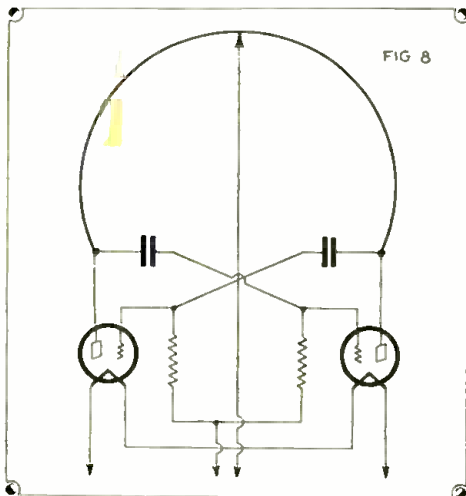

FIG 8

long; the wire ends only about 2 cm. apart, as contrasted with 8 cm. at the start). The tuning condenser shown in Fig. 6 had to be left out and the block condenser bridged.

Among the one-tube hook-ups tried, that of Fig. 7 proved best, next to the already described ultra-audion (Fig. 4). The single winding of the coil (Fig. 7) is interrupted in the middle by a fixed condenser, at the terminals of which the grid and plate wires are connected (over chokes). This condenser I had built as small as possible; the distance between

With the hook-up of Fig. 9, the two coil loops must be coupled together very tightly. That of Fig. 10 one can imagine as coming into being by changing the hook-up of Fig. 9 (say, by swinging the grid coil in Fig. 9 over to the other side, as though on a hinge, and reversing the

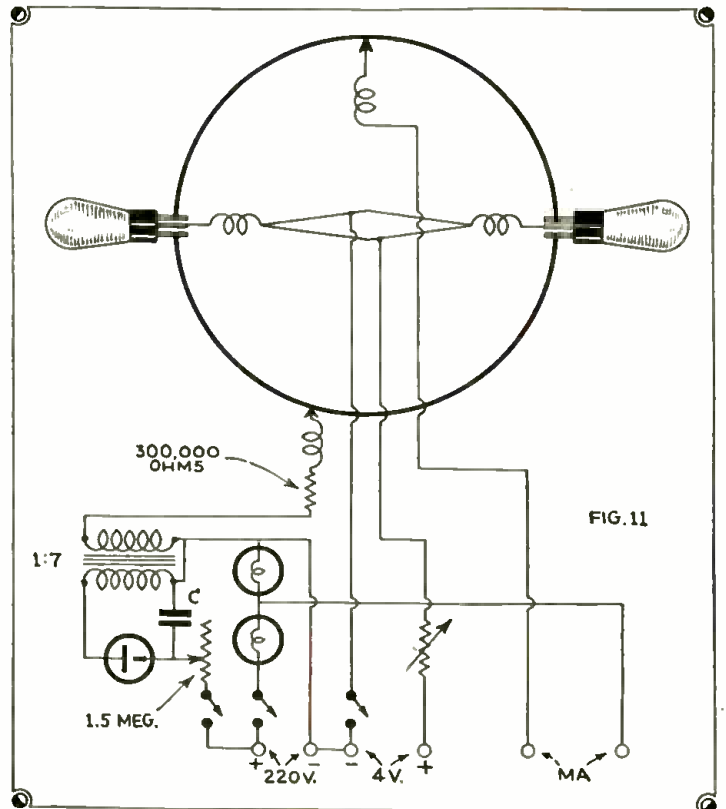

FIG. 11

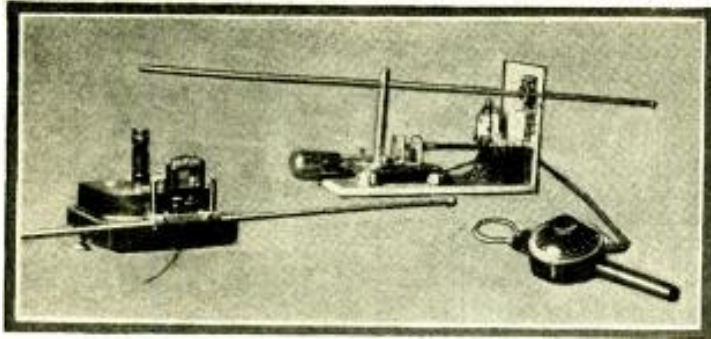

Fig. 7—Vacuum tube receiver for ultra short waves, built according to Gutton and Touly, with field measuring set and wave-meter.

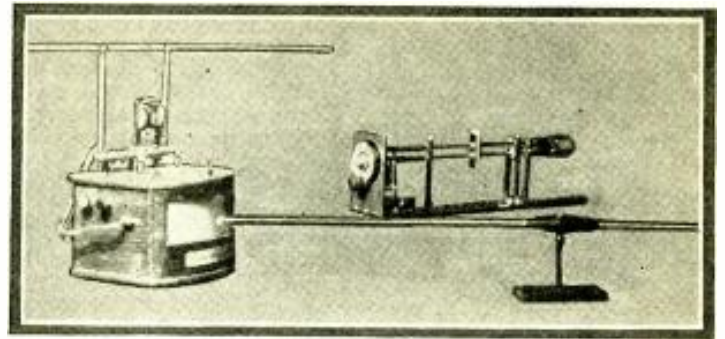

Fig. 8—Field measuring instrument and U.S.W. receiver built after the design worked out by Townsend and Morell.

5 METERS and BELOW!

Very little information is available on the trickeries of waves below 5 meters; we are therefore glad to give our readers the benefit of Mr. Rapcke's experiences with these short wave lengths.

By R. RAPCKE

LET us make a general survey of the field including ultra-short waves of five meters and less. Some of the literature on this field is summarized, and in part a report is made about personal experiments and experimental results obtained in the years 1926 to 1931. Especially notable among literature on the subject is the excellent work of K. Kohl: "Über ungedämpfte elektrische Kurzwellen," in "Ergebnissen der exakten Naturwissenschaften," Vol. 9, pp. 275-338, which every serious amateur is earnestly advised to read.

For general understanding the following brief account will serve:

A. General

1. *Frequency range:* The field in question concerns waves from 5 meters to 5 centimeters, accordingly frequencies from 60 million to 6 billion oscillations a second. In this monstrous frequency range of 5.94 billion or 5,940 million cycles, with the means ordinarily at the disposal of the amateur the waves from

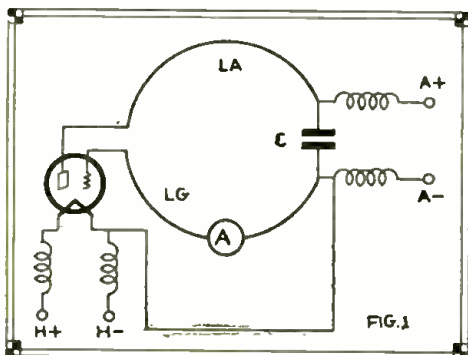

Fig. 1—Hook-up found suitable for wavelengths down to 2 meters. (Gut-ton and Touly.)

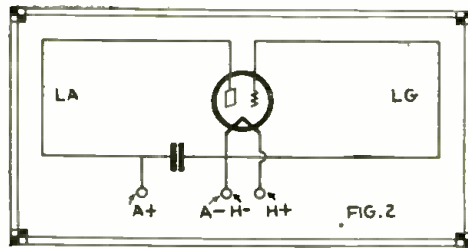

Fig. 2—Circuit suitable for wave-lengths as low as 3.5 meters. (Van der Pool.)

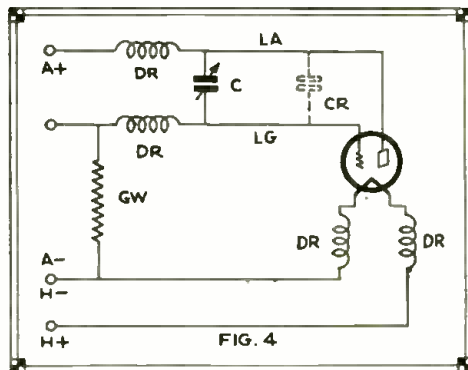

Fig. 4—Ultra short wave circuit; "DR" indicates "chokes" in filament, grid and plate circuits.

5 meters to 1.5 meters can be produced without difficulty. This field however still embraces the tremendous frequency range of from 200 million to 60 million, i.e., 140 million cycles. The range is therefore about 600 times as wide as the 40 meter amateur band.

2. *Propagation:* Concerning the propagation of these waves it is well known at present that reception is only pos-

sible if two stations are within optical vision. For the greatest attainable distances, accordingly, aside from the curvature of the earth, the essentially determining factor is the height of the transmitter and receiver above the surface of the earth. According to the field strength of the transmitter and the sensitivity of the receiver, these factors may, under certain circumstances, be exceeded a little; a refraction of the waves at the Heaviside layer apparently does not occur. As many experiments have proved, effective reception conditions exist even in large cities, right through the walls of houses.

3. *The construction of the apparatus:* For the first experiments almost any kind of construction can be chosen, if the following rules are heeded. Since the oscillation circuits consist mostly of divided self-induction and capacity, watch out for small tube capacities. Subordinate capacities—socket and wire capacity are to be kept small, though this does not mean that the tubes can be used only without sockets. Down to 2 meters—yes, even down to 1.7 meters,

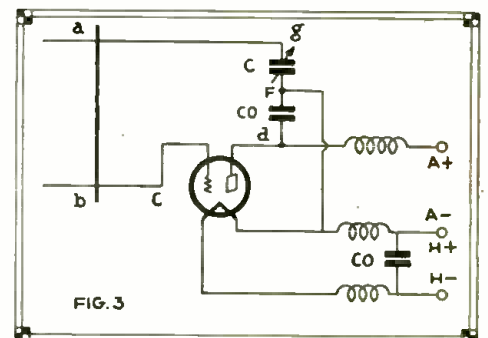

Fig. 3—Minimum wavelength possible with this hook-up 1.10 meters. (Southworth.)

the ordinary tubes can usually be employed without difficulty. Plate potentials required for reception down to 3 meters is at most 100 volts; from 3 to 2 meters 100 to 120 volts, below 2 meters as much as 150 volts. For the transmitter potentials according to tube used (i.e., down to 1.7 meters, average tube with 200 volts D.C.).

The purest D.C. is just good enough for the operation of transmitter and receiver, on account of the easily possible *frequency modulation*. To avoid disturbances, even in experimenting, see to it that you have "pure" D.C. Since the self-induction and capacity effects can likewise easily produce a modulation by mechanical oscillations, watch out for stable construction and secure mountings. In most hook-ups it is best to use straight pipes or tubes (on occasion those which can be drawn out like a trombone, to change the length). These are best stuck directly on the grid or plate pins of the tubes (.12 x .2 inch brass pipes for lengthening .2 x .24 inch, silvered, using an old photographic fixing bath).

Down to 2 meters a distance of 3 cm. (1.2 inches) between the pipe representing the grid circuit and that connected with the plate is just still permissible, on account of the additional capacity of pipes or circuits toward each other. Better still is a distance of about 5 cm. (2 inches), but below 2 meters the necessary curves of the pipes are hurtful. Very essential for the proper functioning of the "U.S.W." hook-ups is the perfect "choking" of all circuit wires; even the heating leads, against the dissipation of high frequency currents; some push-pull hook-ups form an exception to this. The *chokes* are to be wound on small diameter forms and a small distance between windings, or free from capacity (for number of windings, see table).

As a criterion of the quality of the chokes: On spanning the lead wires no fluctuations must occur in the plate milliammeter or the antenna milliammeter. By touching the chokes with the finger one determines, with a simultaneous reading of the plate instrument, whether a choke is perhaps too large. With an already oscillating set chokes can be very exactly equalized by holding one end of the choke fast, and then putting the other end at the "grid" pin of the tube. The number of turns on the choke is altered until no change or else the smallest possible change is determined in the plate instrument.

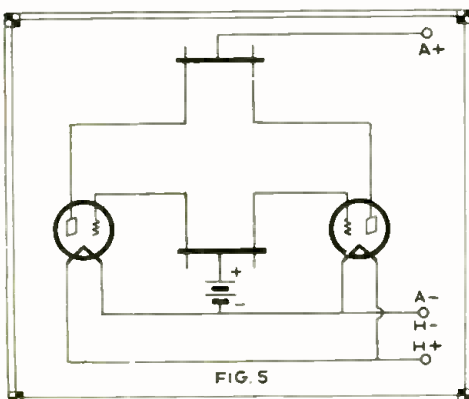

Fig. 5—Circuit suitable for production of ultra short waves down to 2.4 meters. Circuits are tuned by sliding bars as shown.

4. *Tuning*: The tuning capacities coming into use are naturally, so far as they lie parallel to the tube capacity or to the oscillation circuits, very small. Plates a few sq. cm. (1 sq. cm. = 1.55 sq. inch) in size, which can be swung toward each other (or which can have the distance between varied) should be used at 5 meters, down to those of 1/4 or 1/2 sq. cm. at 2 meters, being placed 5 to 10 mm. (.2 to .4 inch)

apart, to afford a rather serviceable possibility of tuning. In practical operation scales fitted with vernier dials are to be used. Since by changing the tubes a great change in capacity is produced, through the change in tube capacity, it is often necessary to provide for a rather coarse tuning capacity, to be able to remain in

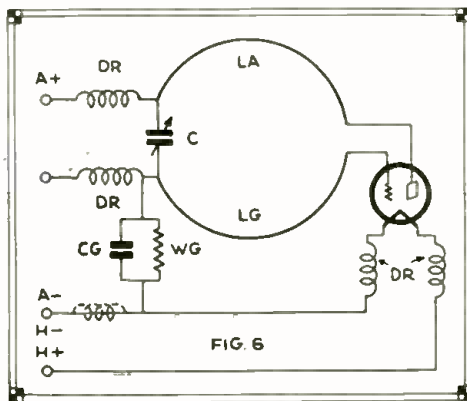

Fig. 6—Vacuum tube receiver circuit adapted to tune in waves as low as 1.7 meters.

the intended frequency band. In the case of sets with straight metal pipes (or tubes) as an oscillation circuit, this condition is generally very easy to attain by using a condenser, which can be moved along the pipes. This block (fixed) condenser, in effect, changes the length of the pipes, since it provides a high frequency "short-circuiting" of a part of them. It is moreover very noteworthy that this capacity in reality lying parallel to the plate potential wire, can be very well used for fine tuning. The, at first, surprising result was found that with variable capacities of 200 to 300 mmf., a very serviceable tuning can be obtained at 5 meters! (Fig. 9.)

At 2 meters, capacities could be used here with about 50 cm. in the variable part. Very special attention is to be paid to the fact that before a tuning capacity is built in, the necessary size should be at least approximately calculated. The fact that the size can be determined only uncertainly, due to the difficulty in estimating the capacities of the different constructional parts reacting on one another, as well as the capacities of the wires themselves, should not deter one from doing a little thinking about it, since only through this work and the

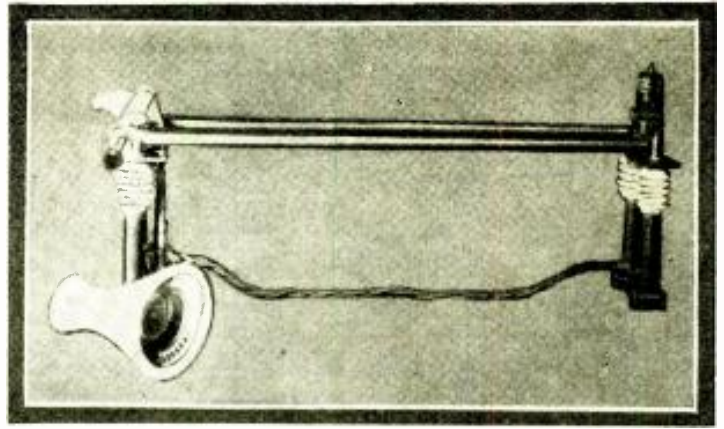

Fig. 9—How Townsend and Morell built their 5 meter oscillator and wave-meter.

experiences obtained afterward, can a reliable design be made.

For tuning a wave it is absolutely necessary to make the scale path, measured by the circumference of the dial, as great as possible. If one considers that 2 to 5 degrees of a 180 degree scale are needed for the comfortable tuning of 10 kilocycles, then it follows that only with really small capacities or fine tuning can a transmitter be accurately tuned for and which you cannot find with too crude means, falsely calculated.

Below is a discussion of the most important hook-ups applicable to the wave range of 5 meters down to 1 meter. Of course I can make no claim to completeness in this compilation, but I think I have given the most interesting hook-ups and those most easily brought into oscillation. In the case of the hook-ups attention is called at the close to the exhibition examples which the participants in the sixth German *Short Wave Meeting* at Hamburg had a chance to see. The hook-up illustrations come largely from the book mentioned above. In the case of the hook-ups now to be discussed, I purposely omit the well-known ones, such as Hartley, Schnell, etc., which all probably, according to design, are serviceable down to 5 meters, often also to 4 meters, and even down to 3.5 meters. But many of the familiar hook-ups cause such difficulties in the case of the ultra-short waves, that the search for more efficient working ones appears justified.

B. Hook-ups

1. Gutton and Touly (Fig. 1). The hook-up shows a variant of the familiar three-point hook-up (Hartley series feed). With normal means it oscillates down to 2 meters, with very good construction, as a receiving detector, even down to 1.7 m. (An example of this design is shown in Fig. 6.)

2. Van der Pool (Fig. 2). A Huth-Kühn hook-up. For easy changing of the wave LA and I.G are to be produced as (brass or copper) pipe-rectangles, which can be drawn out like a trombone. A. Scheibe (in "Die Erzeugung kurzer elektrischer Wellen," Hachmeister & Thal, Leipzig, 1925) used this hook-up with a Telefunken tube RS 59/I with 340 to 420 volts, CA 3600 cm., tube not socketed, with a "choke" in each of the three conductors, 20 turns of .8 mm. (1 mm. = .04 inch) diameter, height 6.4 mm.; 12.7 mm. diameter of the core; he got the following wave lengths:

(Continued on page 60)

The BAIRD Short Wave Converter

This short wave converter is a very compact and efficiently designed piece of apparatus and utilizes but three tubes, one '24 and two '27's. The plate current is taken from the rectifier tube in the broadcast receiver.



Front view of the Baird short wave converter, which has a switch to change the coils for the various wave bands.

THE Baird power converter is the result of four years' experience in the design and construction of short wave converters and receivers. A short wave converter, to be satisfactory, must fulfill the following conditions: First, ease of tuning; second, sufficient sensitivity to work with any broadcast receiver; third, have no whistles or tuning noises when looking for stations. The Baird power converter uses three tubes, a '24 plate detector, a '27 oscillator and a '27 coupling tube.

The '27 coupling tube is the reason for calling it a power converter. It is very inefficient to couple the '24 detector directly in to the antenna circuit of the broadcast receiver, as the "impedance match" is very poor. This is done in most short wave converters with a considerable loss of efficiency, but even using an additional '24 coupling tube does not help much, because it is still a case of working a "high impedance" tube into a "low impedance" antenna circuit. The '27 in this position works out very well. The designers did not incorporate a rectifier in the S-W converter, as it only draws 12 milliamperes and any broadcast receiver will supply this much current. The current is taken directly from the filament prong of the '80 rectifier in the receiver.

Magnetic coupling is used between the oscillator and the detector. This is looked upon by some radio engineers as a source of trouble from "interlocking," but when the proper degree of coupling is arrived at, it is just as good, if not better than any other method.

The S-W converter is designed to operate when the broadcast receiver is tuned in to 1000 kilocycles. In some locations, this setting on the broadcast receiver may bring in a nearby local station, and the converter will operate efficiently on any dial setting on the broadcast receiver from 950 to 1050 kilocycles.

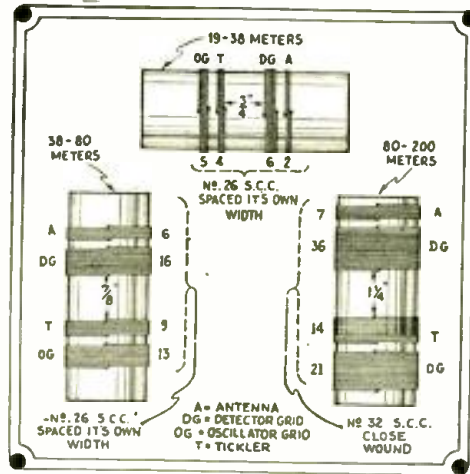

Diagram above gives winding data for the coils of the type used in the short wave converter here illustrated.

One of the diagrams given herewith shows the number of turns on each of the three coils used in the Baird short wave converter.

The 1,000-kc., tuned impedance in the "shield can" shown in the diagram, may comprise about 300 turns of No. 30 S.S.C. or enameled magnet wire, wound scramble fashion, on a small form. Note that the

two main tuning condensers are ganged, as indicated by the dotted line. All the switches changing the coils for the different wave bands are also ganged, and a single knob mounted on the front of the converter.

This short wave converter occupies a very small space, so that it can easily be made a part of any present broadcast receiver, the converter being readily installed inside of the console cabinet in many cases.

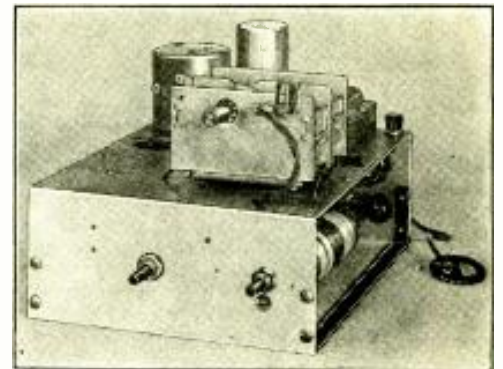

The chassis of the Baird short wave converter, showing one of the coils at the right of the chassis frame. The dual tuning condenser unit is shown on top of the chassis frame.

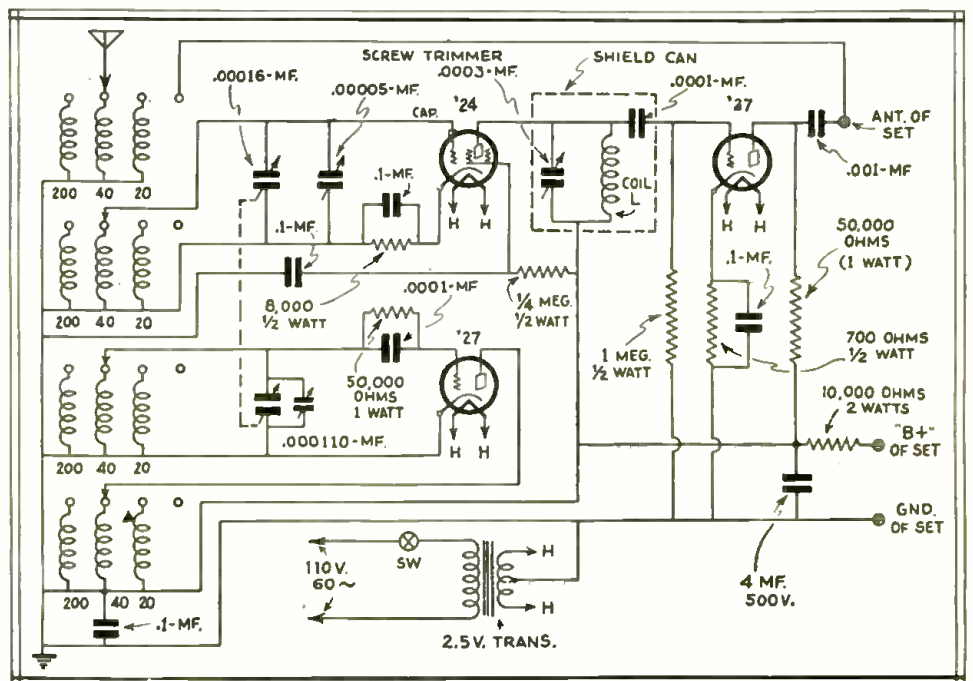

Wiring diagram of the Baird short wave converter, showing how a gang switch changes the various inductances for each change in wavelength, the range being from 19 to 200 meters.

DUE TO MANY REQUESTS
from Our Readers
Mr. Denton Will Describe How to Electrify His S-W "Stand-By" Receiver
in Next Issue

YOU CAN ENJOY Real Comfort With This RECEIVER LAYOUT

By ROBERT "BOB" HERTZBERG
W2DJJ

Among the features of this smooth-working layout are a power amplifier for boosting signal strength; improved phone jack system and a "control" box with a red "pilot" light; loud-speaker switch-over—and others.

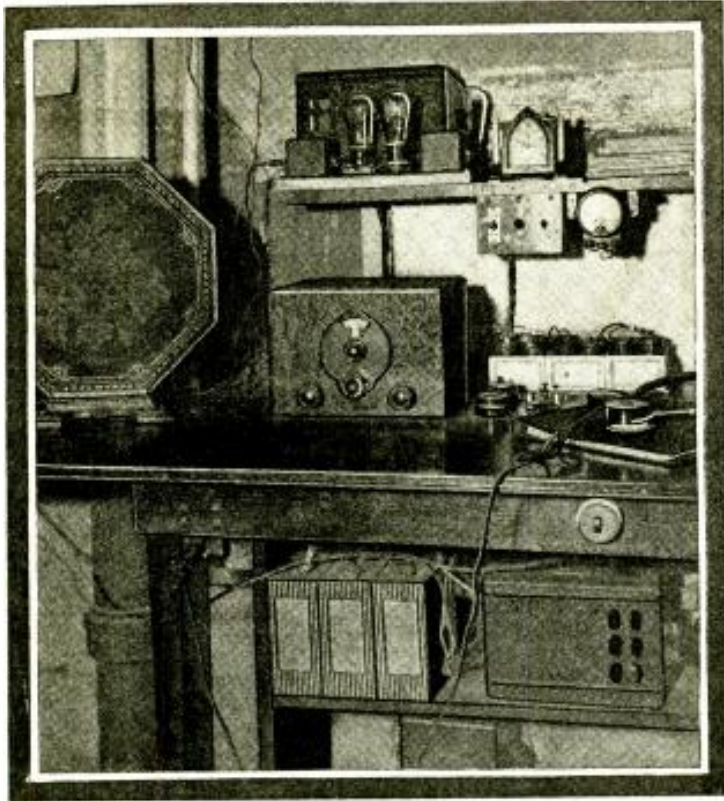

Appearance of smooth-working receiver layout here described.

tector tubes are of the '35 type, the A.F. tube a '27. The filaments are heated by A.C. from a small heating transformer, while the plates are supplied by three 45-volt "B" batteries connected in series. The idea of this combination is discussed in detail on page 339 of the February-March number of SHORT WAVE CRAFT. The receiver is a commercial product, the well-known *National SW-3*.

EVERY short-wave listener appreciates the value of earphones in tuning in those "elusive" stations. Signals that are merely a "noise" in the loudspeaker, can usually be resolved into understandable speech in the 'phones. However, the design of most present-day short-wave broadcast receivers is such that earphones can be used only at considerable inconvenience. The phone jack—if the set is equipped with one at all—is usually stuck away on the back of the chassis, and in surprisingly many cases it is "hot"; that is, it is connected directly to some part of the plate circuits, without an intermediate transformer to protect the operator. If the latter accidentally touches the chassis when he inserts or removes the phone plug, he is likely to receive a stiff jolt of D.C. through his fingers. The

writer has been shocked this way a dozen times, not seriously, of course, but unpleasantly enough to do something about it.

The arrangement that finally evolved out of several experimental layouts is so simple, convenient and effective that perhaps other short wave fans might copy it and save themselves unnecessary duplication of effort. Even if the exact layout is not followed, it will at least furnish ideas that can be applied to individual installations.

The Main Receiving Unit

The main unit is a three-tube combination A.C.-D.C. receiver using one stage of T.R.F. ahead of a regenerative screen-grid detector, which is followed by a single stage of impedance-coupled audio amplification. The R.F. and de-

For loud speaker operation the set is supplemented by a single stage of push-pull amplification, using '45 tubes and energized entirely by alternating current. This amplifier is built up on a board as an entirely separate unit, and in the writer's "den" it is mounted on a shelf just above the receiver proper. This shelf also holds a small control box, illustrated in the photograph and Fig. 2.

Improved Phone Jack System

On the left post of the operating table is mounted a bakelite strip holding two regular, single-closed-circuit telephone

(Continued on page 58)

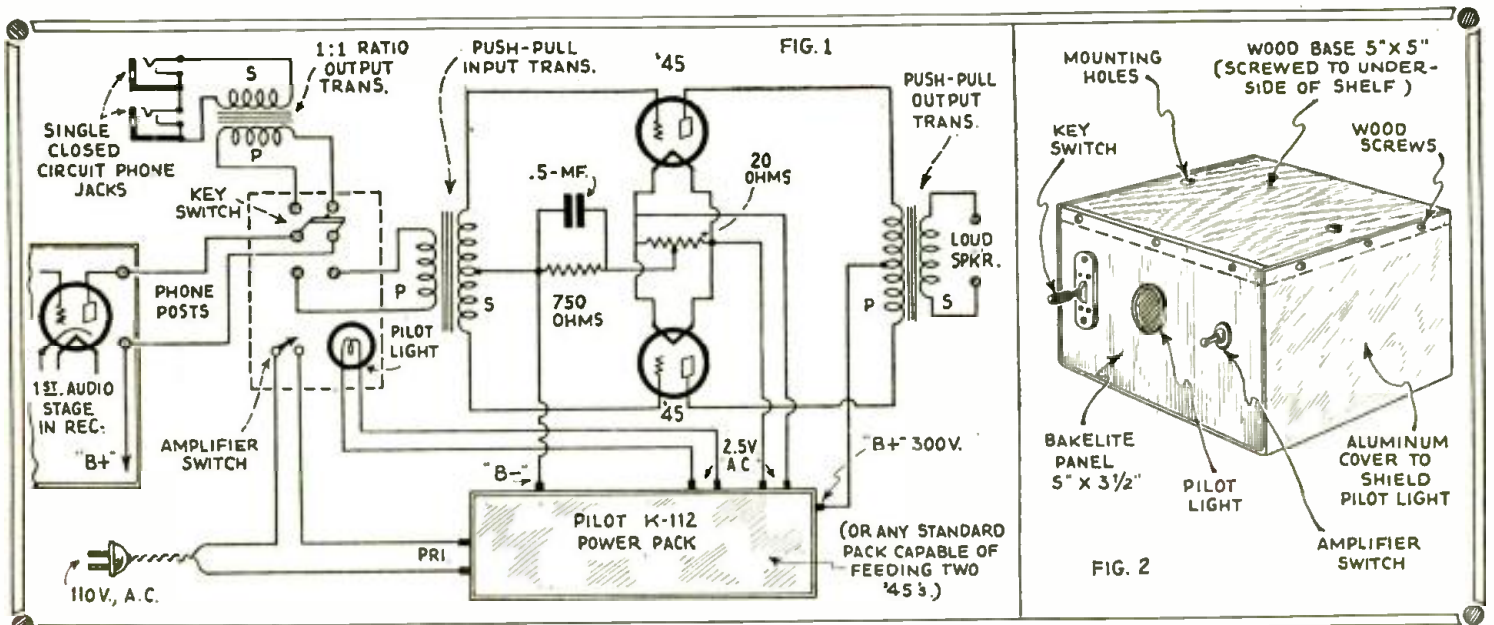

Simple, yet very effective circuits devised by the author, which permit of the smooth transfer of the signal from phones to loud speaker or vice versa; phones are switched into first audio stage to give quietest reception.

The Short Wave Experimenter

5 METER RECEIVERS

By A. BINNEWEG; JR.

Constructional details of practical 60 megacycle receivers giving unusual results at small cost

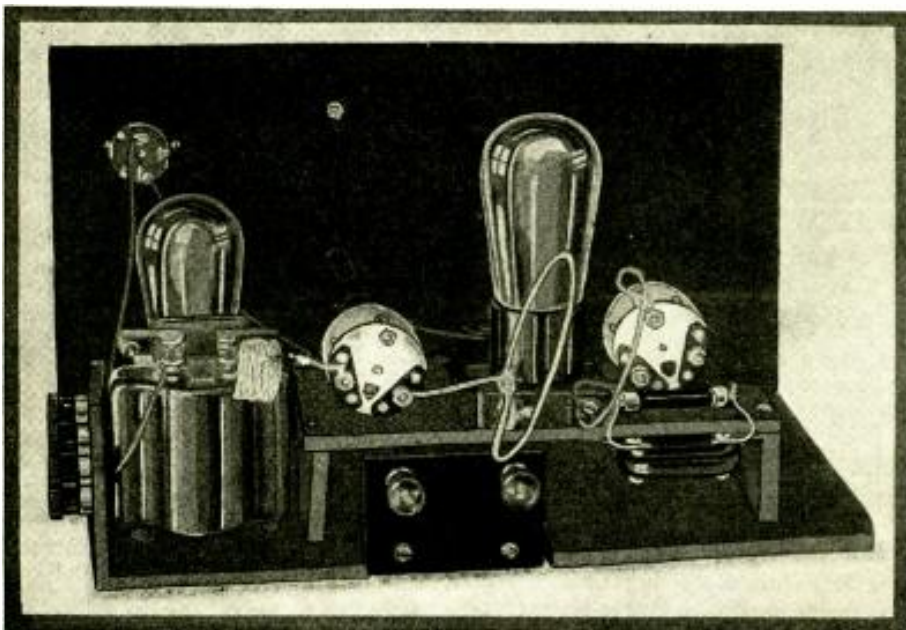

Fig. 4—Five-meter receiver used in tests at the author's pioneer 5-meter station, W6BX. One of these receivers is easily and cheaply constructed.

THE amateur 60-mc. (megacycle—1 megacycle being 1,000,000 cycles) band is experimenter's paradise! It is a wonder that so few use it to explore some of the mysteries that these waves may reveal! If you have the least spark of the experimenter in your breast,—the same stuff that pushed the pioneers into uncharted lands—here's your opportunity! There's some surprises awaiting you. If you want to learn radio—experiment!

Cost of Receiver Slight

Complicated? Expensive? Neither!! Contrary to prevailing opinions, there is nothing complicated above five-meter (60-mc.) receivers. The circuits may be the same as those used at lower frequencies. The cost of these outfits is not worth mentioning. You probably have all the necessary parts right in your "junk box"; and, if you haven't, it won't take a lot of cash to get started. In fact, a 5-meter receiver is easier to build than a receiver which is to be used at lower frequencies. Five-meter receivers are not freaks, either; they *work* and work well at distances of 5 or 10 miles, for example, even when no aerial is used at either the receiver or the transmitter!

Of course, there are precautions to be taken in building a receiver to be used at a wavelength of five meters. Some of us who remember the first attempt

at forty meters, will realize what is meant when one states that the frequency at 5 meters is 8 times that at 40 meters wavelength. A drop from 201 meters to 40 meters means only multiplying the frequency by 5. The electrons certainly are kicking around pretty lively at 5 meters, when compared with their rate at 40 meters! This is mentioned because we realize that a great majority of amateurs transmit at a wavelength of 40 or 80 meters. 5 meters is *different!*

All Connections Must Be "Short!"

The first difference of importance between ordinary "long-wave" receivers and 5-meter receivers is the absolute necessity for using *short* leads. By *short* leads, however, we do not mean leads so short that everything else is crowded. When one starts building up one of these sets, it will be noticed that it's almost out of the question to use anything except the smallest types of midget condensers. If large condensers are used, all sorts of peculiar capacity effects exist between the component parts of the set and, more often than not, it will be impossible to make the set oscillate. Oscillation is absolutely necessary, by the way, because even the amplification afforded by the proper adjustment of the regeneration control on a "long-wave" short-wave receiver, consisting of only two tubes, is dead enough, let alone a 5-meter receiver!

At these extreme frequencies, the coils

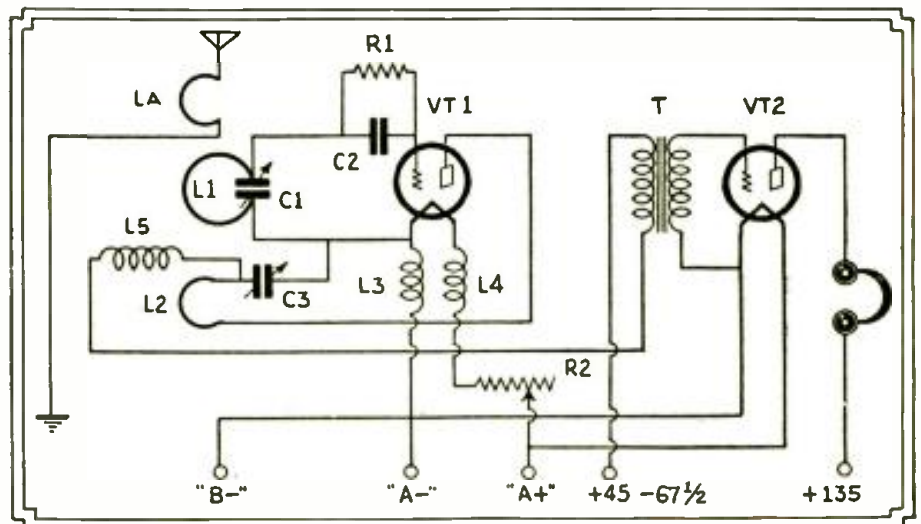

Fig. 1—Complete circuit diagram of two-tube 60 M.C. (5-meter) receiver. The cost of this set is very small.

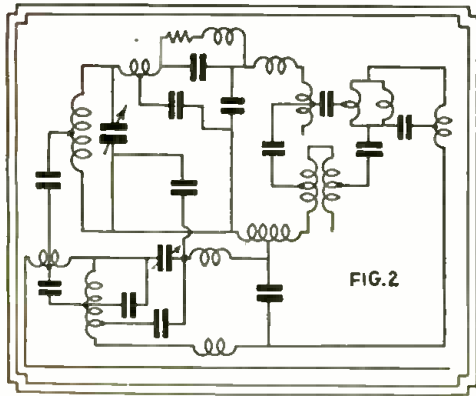

Fig. 2—This is an approximate equivalent circuit of an ordinary receiving circuit as used at 5 meters. Note the possibility for R.F. "leaks"!

themselves consist of only a few inches of wire; so that it is apparent that the inductance of the leads is quite a fraction of the total inductance. It doesn't particularly matter where the inductance is—as long as it's there—provided the set will work with it that way. But it won't!! Keep the coils small, the leads short and away from nearby parts; otherwise you will play some funny tunes trying to get it to oscillate! Don't forget the frequency and the fact that the least trace of capacity acts as a "sieve". All the "feedback" leaves by the nearest exit, and the tube cannot be made to oscillate, even if you use a 100-turn tickler!

Filament Chokes Desirable

Another difference is that filament chokes are often required. It is not

necessary to invent a new kind of mathematics to explain this, either. The answer is that the leads are quite a fraction of the total inductance and the R.F. drop in them is appreciable. This leaves the filament above ground potential; and R.F. currents flow also in the filament circuit. The writer once constructed a 3-meter oscillator employing a '12 tube; the deflection of the plate meter could be changed by a considerable amount simply by touching the filament leads. The use of small chokes in the filament leads will prevent this current loss and the tube can be made to oscillate much easier. The chokes L3, L4 and L5 may consist of about 30 turns of No. 36 wire on a 3/8-inch dowel. The size is, of course, not critical.

Constructional Hints

Fig. 2 gives a rough idea of the complicated circuit that one is dealing with, when designing a 5-meter receiver, without actually realizing it. It is little wonder that some cutting and trying is necessary before satisfactory operation is obtained.

The arrangement of the parts as shown in the photograph has worked out well. Better follow this arrangement at first; extension handles are used on the condenser shafts and note especially that the coils are at the rear of the set. If the coils are placed near the front of the panel, the movement of one's body will change the "feedback" in the set, even from distances of a few feet (depending upon the size of the coils used). The grid-leak and condenser are mounted directly underneath the coils.

The coils are mounted directly on the socket and on the backs of the conden-

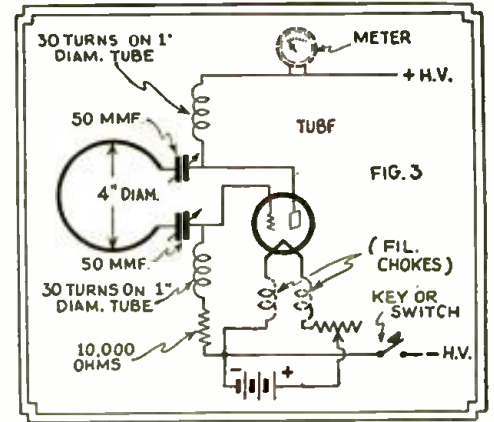

Fig. 3—Circuit of simple 5-meter oscillator. This transmitter can be used to calibrate a 5-meter frequency meter.

sers. Note that the tube is between the two condensers. One can hardly improve on this arrangement as far as short leads are concerned. The parts themselves are mounted on a piece of bakelite raised above the base-board by two wooden supports. This was not done to make the outfit fancy, but to get the dials to the right height on the panel. The audio amplifier is entirely separate and mounted at one side of the base-board. For louder volume, another stage of audio could be added, or a pentode tube can be used in the last stage.

For portable use, dry-cell tubes will be found quite convenient. A type '30 tube will make a good 5-meter detector. There are, however, such great differ-

(Continued on page 56)

Short Wave Hints

SMOOTH REGENERATION CONTROL!

In the October-November issue of SHORT WAVE CRAFT you asked for different methods of controlling regeneration smoothly. Although the appended circuit is not original with the writer, it is quite new, and certainly "does its stuff"; with the added advantage that it cuts down the hum in an A.C. receiver.

To obtain smooth control of regeneration I recommend the following: R1 is a grid leak (different values should be tried) usually from 7 to 3 megohms; R2 is a 2000-ohm potentiometer, which is varied until the best and smoothest regeneration occurs.—John L. Traub, W9FNJ.

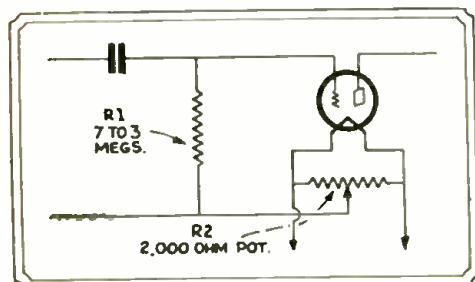

One method of attaining smooth regeneration control.

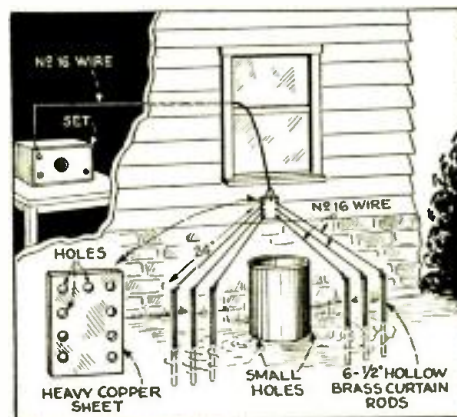

How one experimenter improved his signal strength by driving several brass rods in the ground as shown.

IMPROVED GROUND

Here is a rig which has increased the sensitivity of my single tube WD12 receiver to a point where I can receive foreign stations (VK2ME, NRH, etc.) I started with a single pole to use as a temporary pick-up in place of a damaged aerial. After trying it I drove in another pole to make better contact and found the sensitivity well increased. I then added four more poles, one at a time until the sensitivity was increased to its present high standard. Adding more poles diminished the signal strength.

"PLUG-IN" R.F. CHOKES LATEST

It is a well-known fact that the efficiency of a short-wave receiver depends to some extent on the use of suitable R.F. (radio frequency) chokes.

I am now using a three-tube short wave set, detector and two audio stages, with home-made tube-base coils.

I found that many chokes do not work efficiently on all coils, so I wound R.F. chokes for each coil. I used No. 36 B. & S. gauge wire on a one-inch wooden dowel pin. I drew the leads of the chokes through the two prongs of a tube base and sealed the coil in the base with sealing wax obtained from old batteries. This protects the coil from moisture. The diagram shows how the chokes are placed in the circuit.—John Bolmarcich.

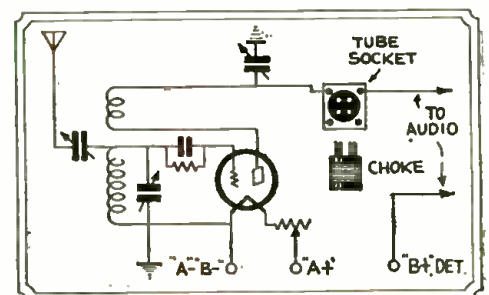

A clever wrinkle—"plug-in" chokes.

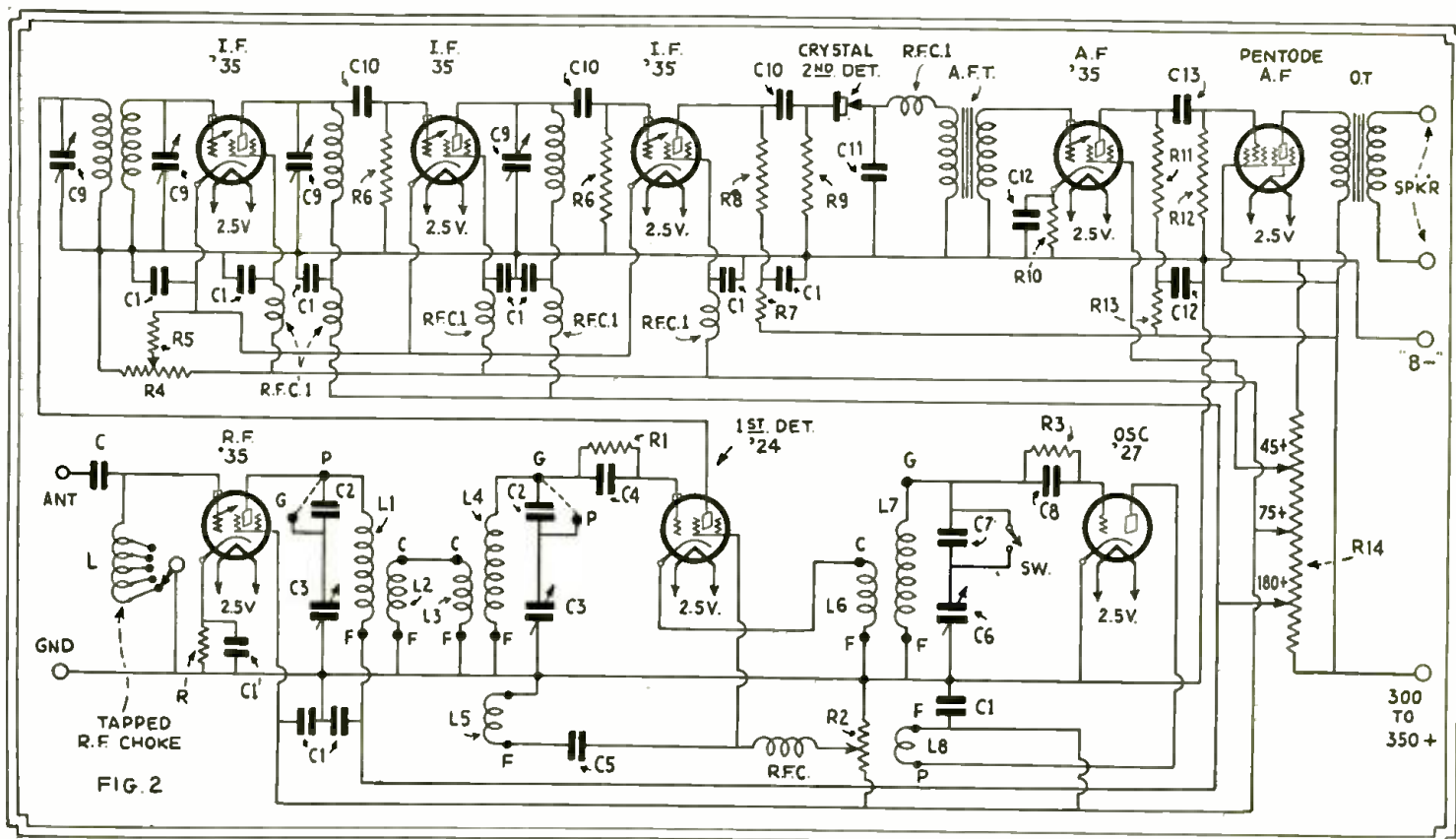

Complete circuit diagram of Mr. Tanner's superheterodyne receiver, fitted with crystal detector, which greatly improves quality of voice. Various wavelengths from 15 to 550 meters are provided for.

A Crystal Detector SUPER With Band-Pass Tuner

By R. WM. TANNER

Better quality and selectivity are outstanding features of this 15-550 meter superheterodyne receiver. A number of new features are incorporated in its design. It's A.C. operated.

THE superheterodyne circuit is as popular for short waves as for regular broadcast wave lengths, due to its high degree of both sensitivity and selectivity. There are many types of "super" circuits, some good and others not so good! The greatest disadvantage of those that are not so good is generally broad tuning in the first detector, which brings in stations beating with the second oscillator "tuning spot." Such interference, while not very bad, can cause confusion to the listener.

15 to 550 Meter Range

The writer has just designed and constructed a "breadboard" layout of a very efficient short wave superhet or, to be more exact, an all-wave superhet, if this term means anything. Certainly, an all-wave receiver would tune from zero to approximately 10,000 meters. The new circuit will not do this, but it will tune from about 15 to 550 meters.

The writer is going to treat this subject in a different manner than usual, by leaving out as much as possible, all theory—merely describing each section and giving sufficient data to enable the experienced short wave set-builder to construct a real superhet.

Let us start first with the input circuit. In order to increase the signal-noise ratio, an R.F. stage is employed. This is a "cross" between a tuned and an untuned stage. In the April-May

issue of SHORT WAVE CRAFT there was described a method of using a tapped R.F. choke coupling the antenna to the R.F. grid. This type of coupling is employed. A small capacity .00005 to .0001 mf., is connected in the antenna lead to remove the normally high antenna capacity from the R.F. grid circuit. A coil is wound on a 1½" diameter form with 200 turns of No. 30 D.C.C. wire. This is tapped at 14, 22, 46, 100 and 200 turns for the 20, 40, 80, television and broadcast bands respectively. The exact values will probably differ in nearly every case, due to the use of various antennas; therefore it would be well to first wind on about 15 turns for the 20 meter band, and after the set is working, remove a turn at a time until signals are loudest with the tuning dials at the high end of the scale. Then wind on an additional 12 turns for 40 M. band repeating the turn removal process. Continue adding sections until the broadcast band is cov-

ered. In each case be sure the dials are at nearly maximum when doing this.

The resulting sensitivity with this coupling arrangement is only slightly below that of a tuned stage, with the added advantage that the "gain" over the range of any set of coils is nearly uniform, since the gain in the R.F. stage increases as the wavelength increases, compensating for the loss in gain in the tuned circuits as the dial is increased.

As with a tuned stage, the signal frequency amplifier should be shielded. The tapped coil may be placed within a shield can with only the switch knob protruding; the tube should also be shielded. A variable-mu tube, either 235 or 251, is preferable, although a 224 can be used.

Regenerative 1st Detector of New Type

A regenerative detector is employed having connections somewhat different than usual. The method of regeneration was suggested by Edward Chappell, an old-time Radio Amateur and now a "sound" engineer. The feedback or "tickler" coil is placed in the screen grid circuit, instead of in the plate, and produces results similar to those derived from the use of a separate regeneration tube. The voltage on the screen grid is varied by means of a 50,000 ohm potentiometer to control regeneration. This tube is never allowed to oscillate and is generally adjusted to a few degrees below oscillation, at the low end of the dial, and then not touched again until a "band shift" is desired.

Band-Pass Tuning Employed

Due to the low intermediate frequency used, 175 K.C., "image frequency" interference would be very troublesome, unless means were provided to overcome it. This is accomplished by employing a *band-pass* or *pre-selector* between the R.F. and first detector, each section of which is coupled by a link circuit of few turns, an arrangement familiar to all of the old-time "hams," who used such a circuit between the antenna and detector grid coils in their three-circuit tuners.

In this new "super" circuit, the gain in the signal frequency amplifier would be considerably reduced, if the output circuit did not have a reasonable match with the load. One section of the band-pass filter being directly in the R.F. plate circuit, produces a reasonable match in impedance. Constructional details of the plug-in coils will be given later on.

Although at the present time, the tendency is towards tapped coils, or separate coils with a tap switch, this circuit sticks to the *only* method of efficiently changing bands, that is, plug-in coils. If a number of coils are placed within a small space and selected by means of a switch, the result can only be large losses. If the separate coils are spaced sufficiently to eliminate absorption losses, the space required would be far too great for any set. Especially is this true with the number of coils needed in the short wave end of this new "super" circuit.

Horn Band-Pass Tuning is Effected

Tuning in the band-pass filter is accomplished by means of two .00035 mfd. condensers belted together (a "two-gang" broadcast type can be employed). Each section has a Hammarlund (or other good condenser) 70 to 140 MMF., semi-variable condenser in series. The condensers are connected to the coil sockets in such a manner that the semi-variables are short when the broadcast coils are plugged in, and in series with the .00035 mfd., sections with all other coils. The semi-variables are adjusted once at very nearly maximum capacity, preferably with the 20 meter coils in circuit, and then left alone.

When the semi-variables are used on the bands below 200 meters, the effective tuning capacity is very close to .0001 mfd., a value sufficient to cover the short wave channels with a reasonable number of band shifts.

Oscillator Details

The oscillator is of simple design, energy being fed to the detector cathode by means of small coupling coils placed at the ground end of the oscillator grid coils. The oscillator tuning condenser has a capacity of .00025 mfd., and is placed in series with a 70 to 140 mmf., compensating type of condenser across which is connected a "shorting" switch. The switch is *closed* for broadcasting and *open* for short waves. Once set, the compensating condenser needs no further adjustment.

All of the coils, except those for the oscillator, have a 35 mmf., neutralizing condenser connected in parallel and located in the top of each coil. These are adjusted in the testing process only once. Their function is to "peak" both sections of the band-filter to resonance.

The I.F. amplifier is not exactly conventional in design since the last stage

is resistance-coupled. Three '35 tubes are used in three stages. The output of the *first detector* feeds into the first I.F. amplifier through a *loosely* coupled band-pass filter; the remaining tuned circuits are tuned impedances. The coils all have an inductance of 8 M.H., and are shunted with 70 to 140 MMF. compensating condensers.

The selectivity, when the coupling in the band-pass filter is quite loose (approximately $\frac{3}{4}$ ") is extremely good; in the vicinity of 10-12 K.C. Unless a smooth high-ratio vernier dial is used on the oscillator tuning condenser, it will be difficult to bring in the weak stations. A 5 to 1 ratio dial will not do at all, a National type B, 20 to 1 ratio, is used with very satisfactory tuning. The same type may be used on the band-filter gang condenser; however tuning is not as sharp here, but much sharper than in the usual form of "super."

"Carborundum" Crystal Detector

As mentioned before, the last I.F. stage is resistance-coupled and feeds into a *crystal detector*. Only a good *Carborundum crystal* should be used, due to the unstable action of most other types when a relatively high R.F. voltage is applied. A crystal detector is and always has been notorious for its *undistorted* output, which is the main reason for its use in this circuit. The tube which normally would be the *second detector* was merely turned into an additional I.F. stage, resulting in considerably greater I.F. gain and an improvement in *tone quality*. It should be noted that the coupling condenser between I.F. and second detector (crystal) must not be greater than about .0001 mf., or possibly as high as .00025 mf., otherwise the signal-noise ratio may be too low for comfort.

The first A.F. stage is a 235 tube which is resistance-coupled to a *pentode* output stage. The entire A.F. amplifier is conventional in every respect and needs no description.

Plug-in Coil Details

Now for the "plug-in" coils: A total of 15 1½" bakelite tubes with 1 16" wall were purchased. These exactly fitted over UY tube bases and were fastened by means of two $\frac{3}{8}$ " long machine screws. When wound they make a very fine looking job. In the table accompanying this article will be found complete details of the windings. All coils are wound with No. 24 D.C.C. wire, with the exception of the "link circuit" coils L2 and L3, which *must* be of the lowest possible resistance. No. 16 wire is used on these coils and it should be remembered that the leads between L2 and L3 should be of the same size.

All windings are closely wound except the 20 meter coils L1, L4 and L7. The turns on these should be spaced about 1/16". Fig. 1 shows how the various coils are located with respect to each other.

In the top of each of the "band filter" forms, 35 MMF. condensers are fastened by means of small brass angle brackets. These condensers are of the screw-driver adjustment type and care should be taken to mount them so that the screw is about flush with the edge of the forms, otherwise it will be difficult to adjust the coils when visibility is poor. Incidentally, a bakelite screw-driver should be made by filing down one end of a ¼" bakelite rod to a screw-driver point. A metal tool would prevent exact "peaking" of the coils.

If the gang condenser is provided with trimmer condensers, they should be removed.

Coil winding details for Mr. Tanner's superheterodyne inductances. Personally, we like threaded forms but if the wire is wound on tight a good job may be done.

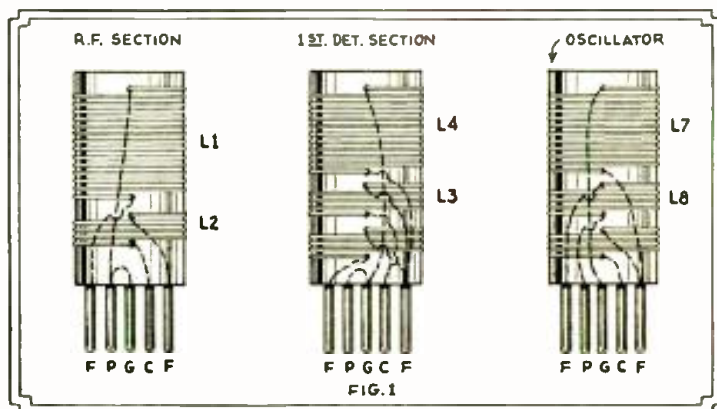

The crystal "second detector" will not require a D. C. bias, since the impressed input voltage is at a rather high value. If a tuned circuit had been used to couple the last I.F. to the crystal, tuning would have been too broad at this point, due to the low resistance of the crystal; signal strength would also decrease.

How to "Couple" Second Detector

The output of the crystal *second detector* may be transformer or resistance-coupled to the grid of the first A.F. amplifier; however the former will probably give higher gain. The transformer should not be of too high a ratio and preferably a 2 to 1. Otherwise the full benefit of "crystal" *clear tone* will not be realized.

I.F. Coils

The 8 MH., I.F. coils may be constructed with the help of any accurate inductance formula or they may be purchased. The F. W. Sickles Co., Springfield, Mass., can supply them at a very nominal cost. Hammarlund 70 to 140 MMF., compensating condensers are very suitable for I.F. tuning, using a double type for the input band-filter and singles for the remaining stages.

The I.F. coils will, of course, require shield cans and a size should be selected in which the trimmers may be mounted at the top with a hole drilled in each for adjustment.

While R.F. chokes were not used in
(Continued on page 57)

A NEW COMPACT SUPER-WAVE RECEIVER

By M. B. SLEEPER*



The new Pilot "Dragon" ALL-WAVE receiver employs six tubes and nine coils to bring in everything from grand opera to police calls.

Left—Front panel appearance of new Pilot "Dragon" 18 to 555 meter super-heterodyne—employing but 1 dial.

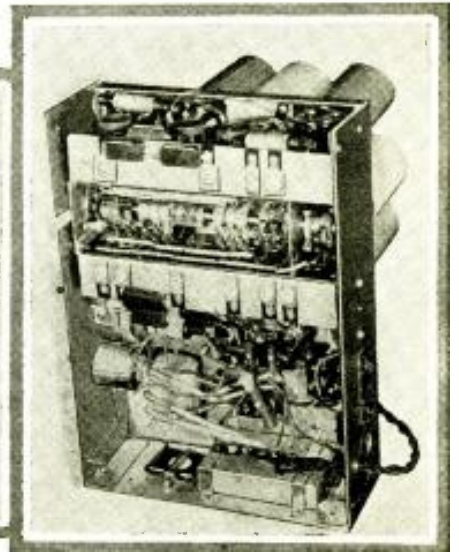

Center—Chassis of new "Dragon" all-wave "Super". Right—Bottom view of "Dragon" chassis, showing catacomb.

WHEN Mr. and Mrs. B. C. L. and the younger B. C. L.'s learned that the short waves were saying a lot of things they couldn't hear, they became all excited. "What, no short waves from our set? That won't do at all!" they exclaimed.

Whereupon Mr. B. C. L. betook himself to the nearest radio store and demanded, "Give me one of those new converters, so I can hear Europe, Africa, Asia, and other points west."

Now, Mr. B. C. L. knew nothing about converters in general, nor short waves in particular, but he had been assured by lurid advertisements that a converter was a thing that made his loudspeaker become linguistic, and by turning the knob to the proper number he could make it say "Uncle" in eleven languages.

The first night Papa B. C. L. had the converter set up, the family gathered around to listen to the world at large. Hm! Something was wrong. Probably a bad tube. The second attempt was equally unsuccessful. Mrs. B. C. L. ventured the remark that no American-made speaker could be expected to speak foreign languages, and returned to her knitting. Mr. B. C. L. twirled the knobs around impatiently until, with a final glower of disgust, he shut off the converter and tuned in a "local" broadcast station.

Soon after, the converter was put aside in the corner and left there until Mrs. B. C. L. tired of dusting around it, carried it to the dumb-waiter and consigned it to the nether regions.

Why, now, does Mr. B. C. L. tell his friends that short-wave reception is just a lot of bunk? Because the converter was no good? Not at all! In the hands

of an expert operator, it might have given a good account of itself.

Some People Make Them Work

Many, many people have learned to operate short-wave converters successfully. They are gifted with skill and patience. But the average broadcast listener simply will not attempt to do more than turn a tuning knob and regulate the volume. He is content to wait until short-wave sets are made as simple and easy to operate as broadcast receivers.

The great listening public will not juggle two or more tuning adjustments.

There, in a sentence, you have the reason for the many startling innovations

to be found in the new *Dragon* receiver, the first all-wave super-heterodyne, covering 18 to 555 meters, designed for *One-Hand Tuning!*

Converter Circuits Are Inadequate

Inexperienced operators expect more of short-wave reception than can be obtained with a converter added to a broadcast receiver. Such arrangements are good, but not good enough. They are simply unsuited to the ideas and requirements of the B. C. L.

After all, no set that is designed specifically for 200 to 550 meters can give maximum results when it is used on 18 to 200 meters also.

Recognizing the necessity for designing a set for the exact wavelength range over which it is to operate, *Pilot* engineers discarded the converter-combination arrangement, and undertook the development of an entirely new kind of super-heterodyne for 18 to 555 meters.

"One-Hand Tuning" Was Knotty Problem

It is easy enough to design a high-efficiency, all-wave receiver, if you can use all the controls you want. Cutting the controls down to two in number can be done without too many headaches. Eliminating the next-to-last knob is what sends the engineers into a "huddle". But the engineers of the *Pilot* staff determined to solve this problem, and solve it they did.

This job led them far afield in an attempt to achieve the unusual by ordinary methods, until they found that all precedents had to be put aside, and the whole problem tackled from an entirely new angle of approach.

Tapped Coils Prevent One-Hand Tuning

If efficiency and selectivity are not given too much consideration, a fundamental circuit, as in Fig. 1, can be em-

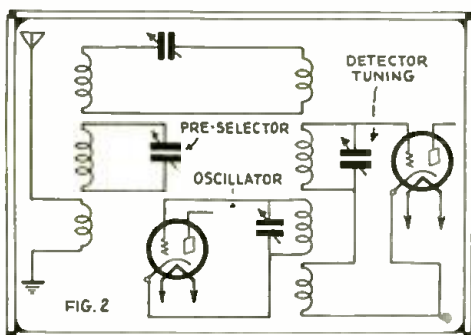
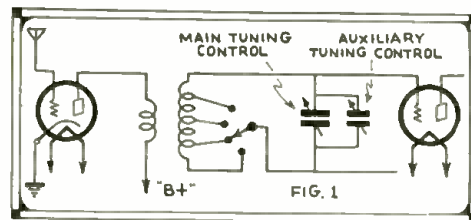

Two elementary circuits used by Mr. Sleeper in explaining development of new 18-555 meter all-wave super-het.

*Pilot Radio and Tube Corporation, Lawrence, Mass.

ployed. To avoid the effect of antenna capacity on the tuning, the antenna is connected directly to the first tube. The tube is wasted, as far as amplification is concerned, but it simplifies the tuning somewhat.

Of course, the tuning condenser and the oscillator condenser will not track at all. That is because of capacity effects in the unused turns of the tuning coil, which are not present in the untapped, separate oscillator coils.

The compensating condenser must be operated over such a range of capacity that the circuit becomes a two-dial receiver, except that there may be no dial on the "compensator".

"46-Point Switch" Gives One-Hand Tuning

We all know that the standard of efficiency is the plug-in coil receiver. Unfortunately, Mr. and Mrs. B. C. L. are simply appalled at the idea of manipulating anything more than a plain knob.

"Plug-ins" are efficient because they have no taps to leave unused turns in electrical association with the used turns. The only way to get plug-in coil efficiency, then, is to design switching mechanism to use with sets of independent coils, so that the coils not in actual use would be disconnected entirely from the tuning circuits.

See how different the fundamental circuit is, in Fig. 2, from the tapped-coil circuit in Fig. 1. The antenna is properly coupled to the tuning circuit, and

only the particular coils for the desired frequency band are in circuit, just as if plug-in coils were used, as far as efficiency is concerned.

To accomplish this result, Pilot mechanical engineers developed a 46-point switch, controlled by rotary switch blades. It may sound simple, but it proved to be an exceedingly difficult device to design.

The arrangement of the whole set devolved around it. Endless combinations, spacings, and arrangements were tried and rejected. This way distributed capacities were too high, that way the leads were too long, or losses were introduced, or the associated parts failed to fit.

Switches and contacts suitable for broadcast frequencies are useless at short waves. Friction becomes a factor, with so many contacts to operate. And so it went, until the engineering department was ready to hang the man who suggested this all-wave idea, anyway.

But gradually, the design for the switch emerged, and with it, and as a part of it, the design for the whole receiver.

Catacomb Unit Equals Plug-In Efficiency

Playing checkers with the coils, connections, balancing condensers, and the switch finally produced not a switch design alone but a complete catacomb unit comprising all these parts.

Instead of considering these associated circuit elements separately, they were co-related in design so that the parts

themselves served as circuit connections, eliminating dozens of connections which, otherwise, would have required complicated wiring.

Tests on the completed catacomb, illustrated in Fig. 3, showed an electrical efficiency just as high as if we had used plug-in coils! Through the elimination of tapped coils, stray capacities, and high-frequency losses, the tuning circuit and the oscillator were made to track perfectly over the entire range of each band. Here is truly one-dial tuning—not two controls with one camouflaged with a small knob and no scale.

Fig. 4 shows the catacomb as it appears from the under side of the net. When it is slipped in place, four screws are tightened, a few connections are made to the rest of the circuit—previously assembled, wired, and tested—and the Dragon all-wave set is ready to operate.

The three broadcast coils on the top of the catacomb, Fig. 3, fit inside the three forward cans shown in Fig. 5. Two of the "cans" have openings to permit the adjustment of compensators for the broadcast circuits. All the other compensators are located conveniently on the under side of the catacomb.

What Can You Hear?

Short-wave reception depends as much upon the skill and experience of the individual operator as it does upon the set itself. The Dragon has already run up (Continued on page 52)

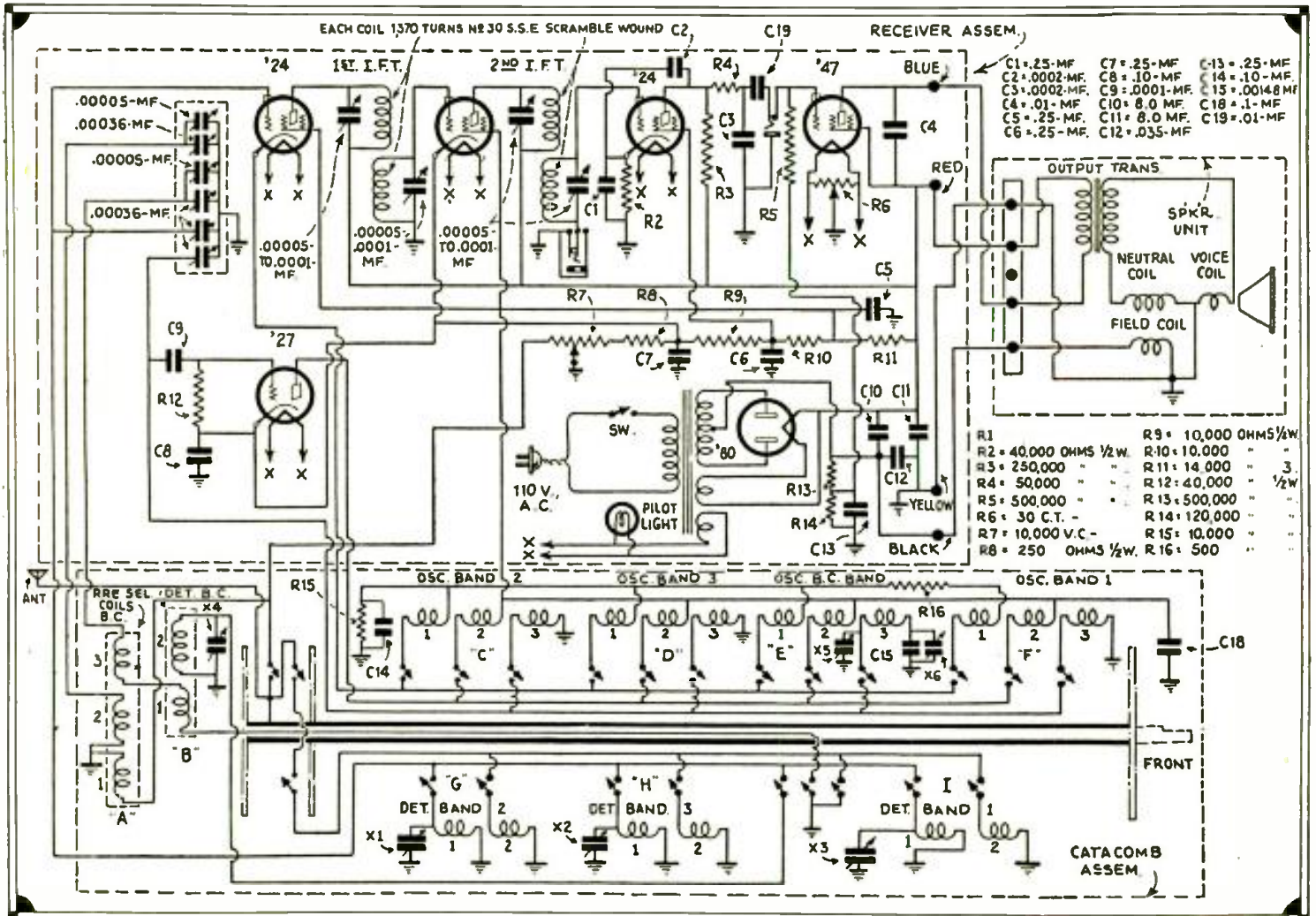

Wiring diagram of new Pilot "Dragon" 18-555 meter superheterodyne broadcast and short wave receiver. A special switch with 46 contacts makes the wave band changes with a twist of the wrist.

A Novel FILTER

for Short Wave Receivers

By HENRI F. DALPAYRAT

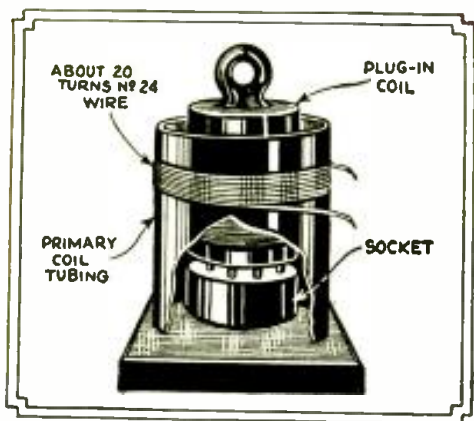

Arrangement of second primary coil "P2", within which plug-in coil slips as shown.

THE writer has conducted many interesting experiments with a view to improving short-wave tuning, and has succeeded in producing a simple and efficient filter arrangement which can be adapted to almost all the receiving circuits designed so far. Fig. 1 shows a popular form of band-pass filter circuit, which is very efficient on the broadcast range between 220 and 550 meters. This circuit provides broad tuning, but with an improved selectivity. However, since this circuit is useless on short waves, a switch is employed to transfer the antenna directly to the first tube circuit, when those waves are to be tuned in. Fig. 2, shows the new short-wave filter circuit, which consists of a small coil L^2 enclosed in a small metal (aluminum or copper) shield and connected in series with the grid lead of each radio-frequency amplifier stage. A small variable capacity C^1 , about .0001-mf., is to be adjusted once, to spread the waveband wanted; and left fixed after that. The spreading taking place only on short waves, below 30 meters, where this action is most needed, will not interfere at all with the longer waves.

Referring to Fig. 2, the desired signal is collected from the antenna by the secondary coil L^1 which is tuned by condenser C^1 . Coil L^2 consists of a very few turns of wire wound around insulating tubing, about half an inch in

diameter. For the 20-meter band, about four turns of copper wire, No. 14 or 16, works very well. This coil, L^2 , is in series with the grid of the tube, as shown in the diagram. Condensers C^2 (such as the Hammarlund neutralizing or "balancing" condensers 20-80 mmf.) are to be adjusted for best results and not touched again.

The theory of operation of this system is as follows: The capacity C^2 , plus the capacity of the tube, which it shunts, is added to the tuning circuit L^1-C^1 and, with the help of coil L^2 , raises the resonance point of the entire circuit; so that L^1 and C^1 are always tuned a little below

justing condensers C^2 ; but the writer found it preferable to leave their adjustments fixed to operate best below 30 meters. The only object of this invention is to make tuning easier on short waves by spreading each station over a few degrees of the dial; doing away with the critical, hair-splitting adjustments within a half-degree, which now prevail in nearly all short-wave receivers; (except those receivers for which the manufacturers supply band-spreading coils).

This new filter system renders possible the ganging of several tuning condensers on the same shaft, in a successful manner, without the extra trimming

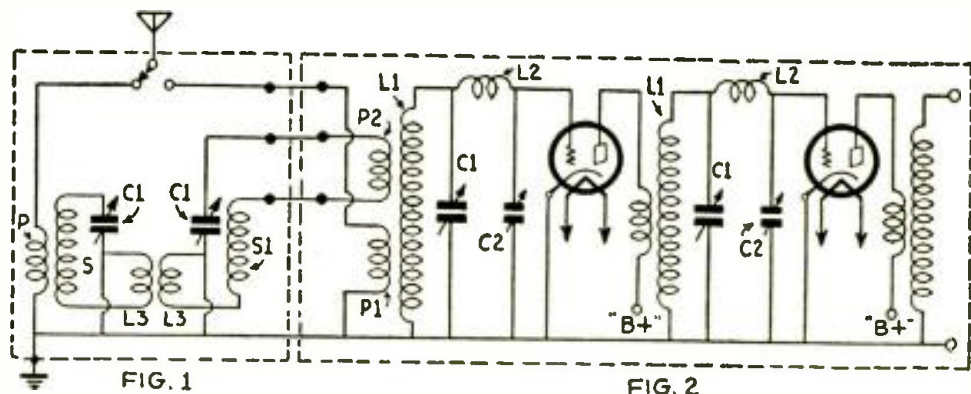

FIG. 1 P, broadcast coil primary; S, broadcast coil secondary; L3, L3, fixed coupling coils, 16 turns each, No. 22 wire, wound on 1/2-inch dia. tube. S-L, broadcast coil sec., with few turns removed to balance circuit; C2, C2, midjet variable condensers .000025 m.f., both on one "grounded" shaft.

the natural period of the entire circuit. It is also well to mention that the circuit resistance increases when the circuit is tuned closer to the natural period of coil L^1 ; coil L^2 prevents exact resonance of the entire circuit, and thus much of this increased resistance is reduced. The tuning on any S.W. band can be made sharper or broader by ad-

justing condensers which are so bothersome to adjust. Long-distance reception is much improved by this system; since it is easier to locate the stations and more regeneration can be forced through to increase the signal strength without "spilling over," while greatly reducing self-oscillation with its annoying whistling interference.

A STABLE Small TRANSMITTER By H. WOLTMANN

THE balanced generator shown in schematic circuit is excellently suited to produce ultra-short waves. As a result of the push-pull hook-up, the stability of frequency and the energy output are excellent. Naturally, in using this hook-up, certain points of view are to be taken into account, which are here especially considered.

The arrangement for producing oscillations down to about six meters is shown in the illustration. In order not to disturb the balance (of the distribution of the high-frequency potential over the coil!) the high plate voltage must be conducted through a choke into the center of the coil. This choke can, however, be done away with in the case of an exactly adjusted tap; since by means of the tap we find ourselves at the electrical center. The chokes, which must be adapted

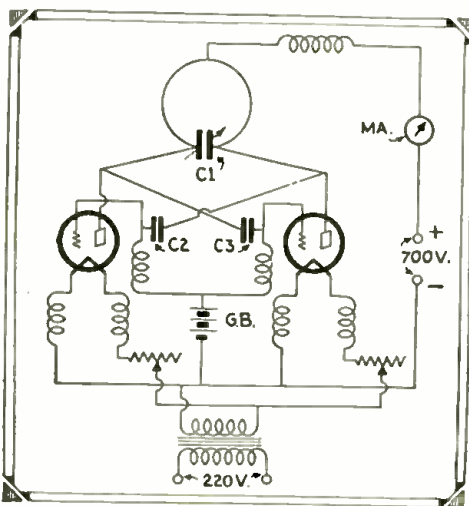

Balanced generator, well suited to ultra-short waves.

to the extremely high frequencies, consist of a few turns of bell wire.

For waves between 4 and 7 meters I use about 12 turns on a 3/4-inch diameter. In one experiment the two grid chokes consisted of about 250 turns of No. 34 wire, in the form of cylindrical coils one layer deep, with a coil diameter of 5/8-inch. It is not always necessary to put chokes in the filament leads; and in most cases they can be left out. The parts used, for waves down to about 6 meters, were as follows:

- 1 variable condenser, 100 mmf.
- 2 fixed condensers, each .00025-mf.

The coil consisted of a turn of 1/8-inch copper tube (the diameter of the coil being ten inches) mounted directly on the variable condenser. To keep the anode plate leads as short as possible, ro-

(Continued on page 47)

TO short wave set owners and builders "dead-spots" are familiar enough phenomena. The author's experience with the nuisance has been rather complete and leaves him with an abiding respect for their powers. For several weeks, not so long ago, he had nightmares in which coils, condensers, the chief engineer's wrathful face and a big black spot prominently figured. Yet most "dead spots" are simple things and easy to locate. If the theory

DEAD SPOTS

Their Cause and Cure

By EDGAR MESSING

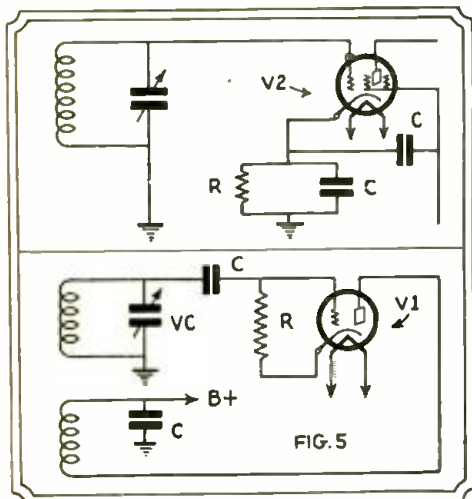

Short wave oscillator-detector combinations may have cancellation dead spots.

behind them is once understood the average constructor will usually be able to render them impotent.

Two Principal Causes

Experience has proven that dead-spots can only be due to either of two reasons: *absorption* or *cancellation*. In other words a dead-spot is due either to a signal's being absorbed before reaching the desired circuits, or after reaching them, it is nullified by some secondary effect.

A "super-het" type of receiver may have dead-spots due to either or both phenomena; a regenerative T.R.F. set usually can credit its null points to absorption.

We can probably get a clearer picture of just how dead-spots are born by examining some commercial circuits in which the problem was met. Fig. 1 is the diagram of the detector stage of a well-known set, with some slight changes to eliminate unessentials. It will be noticed that a switching arrangement is used rather than plug-in coils. Such a set-up complicates the dead-spot problem, because it necessitates the use of a number of coils, all located within a limited area, with accompanying questionable and disturbing coupling effects.

A Case in Point

A test of the circuit of Fig. 1, revealed two dead-spots; one at a dial reading of 20 on the first band, and the other at 90 on band two. Band one was investigated first; all coil connections to the switch except the first coil's were removed and the test "re-run". The dead-spot disappeared. Each coil was then

connected in turn to the switch and the stage tested before the next coil was put into the circuit. This procedure was followed until the deadspot reappeared, which it did when the No. 3 tickler coil was connected to the switch. Checking proved that this coil was causing the trouble; with the help of Fig. 2 we shall see why.

The R.F. current in the plate circuit of the tube ostensibly travels from the plate to the switch S1, and to the coil connected to the contact on which the switch arm rests, and then to the ground and cathode. Actually, at the switch there are two other paths open. Between

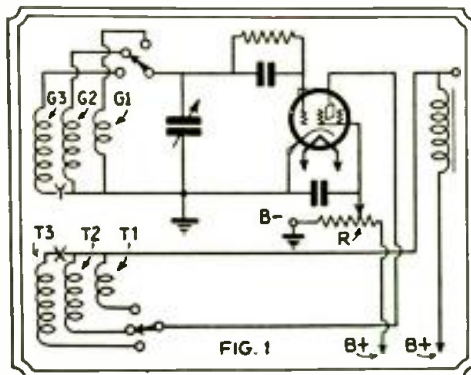

This regenerative circuit had two "dead spots"—read how they were localized and eliminated.

the switch contacts there is a certain amount of capacity represented in the figure as C and C1, so that some of the R.F. passes through these and their respective coils back to ground. The R.F. will, of course, go through the path of least impedance.

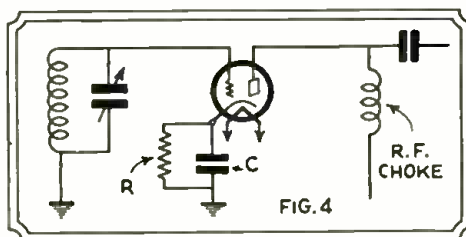

The R.F. stage may have two "dead spots"

The No. 3 tickler coil was apparently series-resonant; that is, its inductance and capacity were balanced out at the frequency corresponding to 20 on the first band. The coil was then a dead short-circuit through C1 across the No. 1 tickler and all of the R.F. was going through it and very little through the No. 1 coil. Since No. 3 was not coupled to the No. 1 grid coil there was no regeneration.

The Solution

The solution was not so obvious. In-

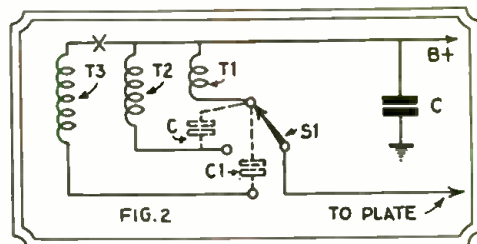

Illustrating simplest type of "dead spot"—caused by capacity effect at switch.

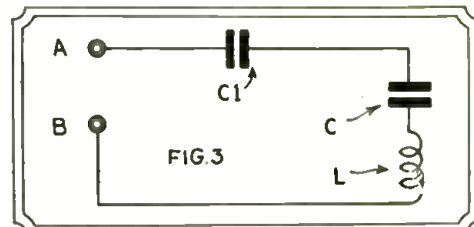

Equivalent coupled absorption circuit.

creasing the number of turns on the No. 3 tickler only moved the dead-spot to a higher wavelength; decreasing the number of turns would be satisfactory, if the dead-spot could be removed below the zero setting on the dial and if satisfactory regeneration could still be obtained on the third band. Experiment proved that it was not possible to decrease turns and still have regeneration.

The final answer was straightforward enough: The question resolved itself into whether there was some way of increasing the impedance of the short-circuiting path, so that more of the R.F. would go through the No. 1 tickler. And the result was that a small 500-ohm resistor was inserted at the point marked "x" in Figures 1 and 2. This worked very nicely and its value was not at all critical. A higher setting of R was, of course, required for oscillation on the third band, but this was easily overcome by adding turns to the No. 3 tickler.

Before going further we may do well to point out that frequently it is possible, in similar cases, to use the method of increasing turns as mentioned above. The point is that while the dead-spot may be shifted to a higher wavelength or lower frequency that at this frequency the amount of coupling is decreased. Figure 3 may make this clearer. Suppose the arrangement from A to B to be the coupled circuit causing the trouble, and that L and C are the resonating units, with C1 the coupling capacity. If L is increased L and C will now resonate

(Continued on page 55)

Letters From S-W Fans

YES, WHY NOT?

Editor, SHORT WAVE CRAFT:

Have you ever taken into consideration your page entitled, "Among the Hams"?

Why not call it, Among the Short Wave Listeners, as I think it would be a better title as very few Ham Letters are ever published.

Hams are not Short Wave Listeners and do not want to be classed as such. A Ham talks to other Hams and does not set and just "Listen".

Why not give the Hams a page of their own and the Short Wave Listeners one of their own.

Being a Short Wave Listener for a year or so I find that the Hams do not exchange ideas with the Short Wave Listeners. Although a Ham now, I know how to appreciate the fact.

Kindly give this a thought Mr. Editor and let's see this published and get the ideas of the others.

Luck and 73.
WSEEQ,
Official Relay Station,
F. M. WENTZ,
216 Pine St.,
Pindlay, Ohio.

(Believe it or not, we have been thinking along the same lines as Friend Wentz, and have now made the change; we would like to hear from more readers. Let's have your say—what say?—Editor.)

MARS NEXT!

Editor, SHORT WAVE CRAFT:

Have just got current number of SHORT WAVE CRAFT, and think it is fine. Have read every issue so far. "Among the Hams" is O.K. In fact, the whole book is well worth 25 cents.

Several times lately, I have read the correspondence of some of your subscribers, and find quite a few errors, in regards to pulling in certain stations on short waves. For instance, UOR2, in Vienna, NXC and XFD, in Mexico City. These fans should check, and be certain the stations they mention are in existence. The above mentioned ones were not past the license stage when some readers reported them.

Here is my DX record. The following stations have verified my reception reports to them, with QSL cards or letters: GBA, GBC, GBK, GBP, GBS, GBT, GBW, GBX; VE-9BY, VE-9BM, VE-9AP, VE-9CL, VE-9GW, VE-9IR (old CIRX), VE-9DR, VE-9CS; HKA, HKD, HKO; LSN, LSN, LSM; "El Prado"; "Rabat." on 2 waves; "Zeesen"; XDA on three waves; NAM, on 2 waves; TI-4NRH; HRB; CT-1AA; EAQ; G-5SW; I-2RO; "Moscow"; FYA, on 3 waves; FTN, FTM, PTL; VK-3ME and VK-2ME; LSY, LQE; PLE, PMC, PLM, PMB; J-1AA; PCJ; X-26A; VLK; YVQ, 3 waves. The following ones never verified my reports: HIC, HKE, HKF, HKN, HIC-1A, HC-1DR, HC-1FG, PPQ, PPU, VRY, CMCI, VUB, VUC, VS-1AB, VQ, 7LO. Have received letters of verification also from the following: KEZ, KES, KMM, KKQ, KKZ, KEQ, CN, SMC, KKP. Am waiting for my verifications now from the following: F-3ICD, FZS, FZR, FZG; PLV, PLW; HVJ, HJY; CEC; OXY; RV-15; EAN; I-3RO; ZLW; VPD; KEL, KEE, KAZ, KBK, KIO, KRO.

I have heard practically every station on the air that can be heard in this part of America. The only U. S. stations I have bothered with are: W-9XP and W-2XAF. I have also the following ships that have verified, GTSB and the *Empress of Britain*. Have heard the others, GBSQ, GKPY, DDAS, DDDS, WBSB and GDLJ, but have never wrote for verification. Last month I got two new ones, K-6XO in Hawaii and W-6XF in California. Am waiting to hear from these now.

My receiver is a "Pilot Super Wasp" built over from D.C. to A.C. with a stage of 45s in push-pull added. My antennas are a 40-meter Hertz, one inside, and one 105 feet long outside. Have heard commercial stations (coded) in 52 countries, amateurs in 19 countries. Can any of your readers beat this record? Should

any one doubt my word, I refer you to back issues of the *International Short Wave Club's* magazine, as well as the January issue, where you will find I have reported dozens of new ones. Any one living in this vicinity will be welcome to drop in on me any time, for a "rag chew" and some "listening".

Sincerely,

R. H. TOMLINSON,
16 Hawthorne Ave.,
Port Chester, N. Y.

(Evidently this sort of thing can go on for years and years, and we are sure that Friend Tomlinson only stopped writing because the paper gave out. But speaking seriously, this is "some log," and we feel pleased to have such readers among you.—Editor.)

THIS BOY SURE TRAVELS

Editor, SHORT WAVE CRAFT:

Have been reading your last six copies of SHORT WAVE CRAFT and will say that it sure hits the spot in a non-technical way and so everyone can understand the peculiarities of short-wave reception. I have enjoyed the ham-section very much and thought that I might tell you of some of my records. My short wave station list of reception covers the world and in the following countries: Java, China, Japan, Central America, Holland, South America, Mexico, Germany, Canada, Africa, France, England, Spain, Australia, Philippines, Soviet Russia, Portugal, India, Italy, Cuba, Porto Rico, Siam, and all of the 9 ham districts. The stations are too numerous to mention but are spread among these countries. On the long waves I have covered about 275 stations from coast to coast and the bordering countries.

I hold verifications from all these foreign stations and from the most distant in the U. S. I do not believe in outdoor antennae so use just 60 foot inside the house and use a Pilot Super-Wasp with extra stage of audio. When daylight saving ends I expect to add some extra countries to my list this year.

The only thing that I cannot understand is why we do not use loops for transmitting purposes, as they have been somewhat successful in Europe. It seems to me that this would be sort of beam transmission in itself.

I wish to join the "Swappers" Club of your magazine also and would be glad to hear from any one I could help or swap experiences with. Yours for continued success with SHORT WAVE CRAFT.

I am, very truly yours,

ADOLPH DICK, Jr.,
263 Lincoln Ave.,
Brooklyn, New York.

(You said a whole aerial full Adolph, and you certainly made a fine showing. Keep up the good work, and let's hear more along the same line from other readers.—Editor.)

PITY HIM

Editor, SHORT WAVE CRAFT:

I have been reading your magazine for about six months now and would like to say a few words.

I am a "ham" and my calls are W9HQH and W9HWY (portable). I would like to start a school for "would be hams"; that is I am willing to send out code practice for 15 minutes, twice a week, if there are enough fellows interested to make it worth while.

I transmit on the 7000 K.C. band and have worked 35 states and all districts.

If I can get enough letters from the boys telling what time is best, I can arrange the best time to transmit. I am willing to help all beginners in this city (Chicago) that will get in touch with me by mail or telephone.

Well I guess that is all and please help me get this started.

W1 73 CU AGN SN I HPE,

I remain,

FRANK H. MILLS,
2524 N. Central Park Ave.,
Chicago, Ill.

Phone No. Spalding 6439.

P. S.—I have been using "ham" slang so long I can't spell; so please correct my spelling, if you print this—III III.

(Now listen Frank, you only have to blame yourself for what is in store for you now. You will be sniced under in short order with requests from SHORT WAVE CRAFT readers and we put you upon your honor to answer each and every one of the letters, just to make an example of you, and when it does happen here is an editorial III III for you.—Editor.)

A STATISTICIAN!

Editor, SHORT WAVE CRAFT:

Allow me to congratulate you and your staff on the very fine magazine, SHORT WAVE CRAFT. It is indeed an important link for the radio enthusiast who is striving to get a foothold in the entrancing realm of the more complex high frequencies.

Most new magazines appreciate criticisms from their readers; may I add a constructional criticism or two? Most radio magazines hesitate when it comes to printing mathematics in their articles—however I believe that a fairly large percentage of your readers would understand the simpler forms of equations and many would be able to wade through the more complicated forms of calculus. My suggestion is, therefore, to print one article with a mathematical treatise in each issue of the magazine. Then, too, descriptions of the latest types of apparatus, hook-ups, high frequency phone and code transmitters, etc., are always welcome. Your policy of publishing experiments and advancements of foreign countries along the lines of short waves, is, I am sure, appreciated by all of the readers of SHORT WAVE CRAFT.

The real purpose of this letter was not to criticize, but rather to ask a favor. I am deeply interested in that old problem of the elimination of static, strays, X's, atmospheric disturbances, or call it what you may. My investigation has covered practically all the books and articles written on the subject, and with subjects closely allied to the main subject. However, my experiments have been very limited. Now it is my wish to hear from all those amateurs and broadcast listeners who have had any experience, or who have been able to partly eliminate static. My personal observations are far too narrow, and thus I seek the help of other radio enthusiasts, to further my research. I will be glad to exchange information on the subject, and I assure you that all letters will be answered.

I notice that some of the readers express their desire to have this a monthly magazine. I should rather see SHORT WAVE CRAFT a thriving magazine published once every two months, than to have it published once a month, and a financial failure. (No reflections on the staff.)

Best wishes for a prosperous future, and thanks for the help.

FRANCIS C. KRAMER, W9DEI,
1728 W. Wis. Ave.,
Milwaukee, Wis.

(You sure have asked a whole condenser full, Friend Francis, and if we don't miss our guess, the forced oscillations which will reach you pronto, in letters from fellow readers, will know you under.)

There may be a "static eliminator," and there may come a day when static is eliminated, but frankly, we have our doubts. Static, in our estimation, is like the poor: we always have them with us.—Editor.)

An Economical S. W. Receiver

By LEWIS EWING, W8ECH

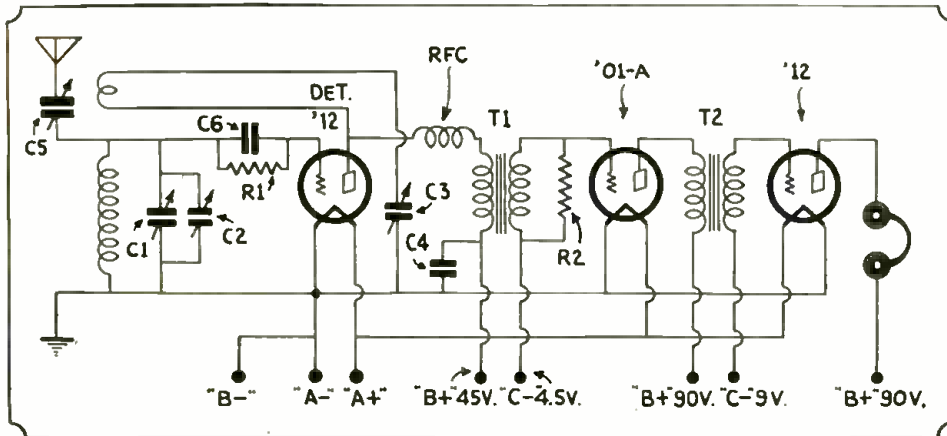

The author tells how to construct a short wave receiver from odd parts; also how to spread the bands over the dial. Some excellent advice is given in this article by Mr. Ewing.

ers, both in stator and rotor. For the tank condenser (C1), I took out half the plates, leaving four in the stator and four in the rotor with single spacing. In taking out plates one must remember to put in more washers to replace the plates taken out. If this is not done, the condensers may be noisy and not work smoothly.

For the regeneration control (C3) ten plates were left spaced the same as the tank condenser. Since I was building the receiver for amateur use I had to have some means of spreading the bands; so, as I still had one more condenser, I used it for that purpose (C2). Two plates were left in the stator and one in the rotor. The stator plates were triple-spaced; this spread the forty-meter band over 90 degrees on the dial, and the eighty-meter fone band over about 60 degrees. The spacing is adjustable by a screw at the back of the condenser, so that the bands may be spread over almost any limits. This disposed of the variable-condenser problem; and these

(Continued on page 49)

SHORT-WAVE RADIO is a very interesting hobby, but unfortunately all of us haven't the cash to build a good short-wave receiver. Therefore, when we invest in parts for a short-wave set, it behooves us to select them with an eye to economy as well as quality. At the present time, since the advent of the all-electric

broadcast receiver, there are many battery sets for sale at very low prices. One popular battery receiver was the Atwater-Kent model, built in breadboard style; the one in which the variable condensers are enclosed in metal cases.

These condensers are very easy to cut down for short-wave use; as the plates are not soldered but separated by wash-

By CLIFFORD E. DENTON

MANY experimenters have written for information on the operation of the superregenerative receiver with the new six-volt tubes. A great percentage of the letters which the author has received regarding information covering this circuit has been from outside the United States. For this reason I append a chart giving the constants of this new series of tubes.

It will be noted that the "output" stage has been altered so that there are two tubes used in parallel. This is done to lower the output impedance of the '38 type pentode and increase the power output, which is quite low in this tube. It is difficult to obtain an output transformer with an output impedance of 15,000 ohms at about 90 cycles. Thus by using two tubes in parallel, the output impedance is reduced to 7,500 ohms, which is more satisfactory.

The screen grid '36's have to be selected by actual test in the receiver, until a really good tube is obtained. The author has ascertained that the only way to find a good detector for this circuit is to keep testing for it under actual receiving conditions. The success of the receiver as a whole can always be traced to the "detector" tube.

The Superregenerative With the New "Six Volt" Tubes

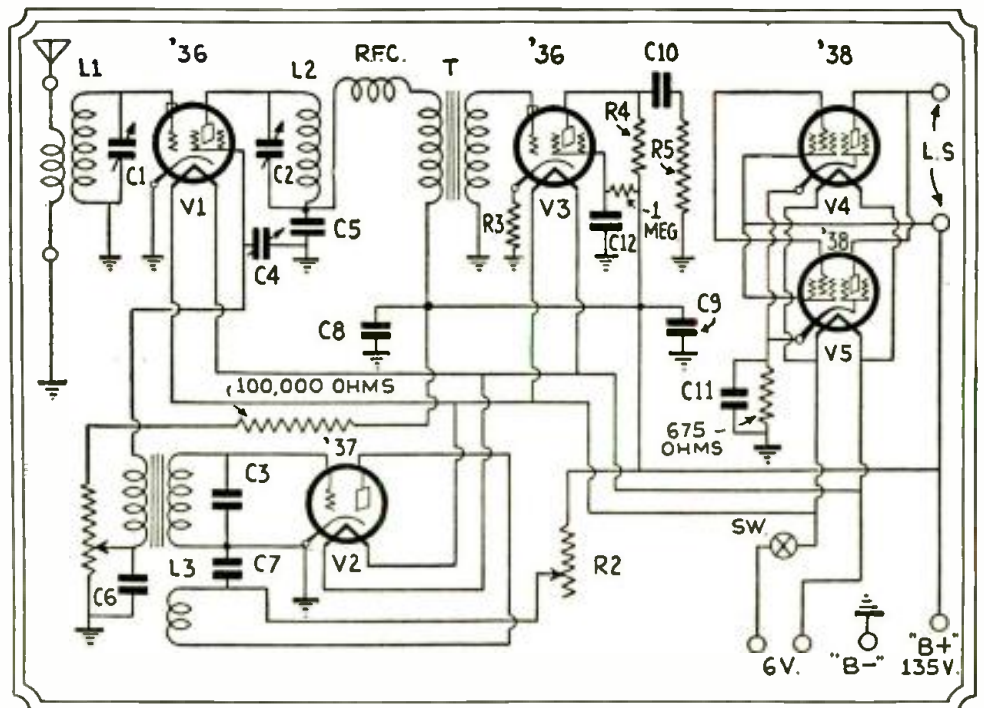

Many inquiries have been received by Mr. Denton, asking how to use the new "six volt" tubes in the superregenerative; this information, with data on the tubes, is given here.

Six Volt Tube Characteristics

	'36 Screen Grid	'37 General Purpose	'38 Pentode
Filament Volts	6.3 v.	6.3 v.	6.3 v.
Filament Current	.3 amp.	.3 amp.	.3 amp.
Plate Volts	135 v.	135 v.	135 v.
Plate Current	3 ma.	4.3 ma.	9 ma.
Screen Volts	67.5 v.		135 v.
Bias	1.5 v.	9 v.	13.5 v.
A.C. Plate Resistance	300,000 ohms	10,000 ohms	102,000 ohms*
Mutual Conductance	1050	900	975
Amplification Factor	315	9	100
Power Output		80 milliwatts	525 milliwatts

*Operating load recommended for minimum second harmonic output 13,500 ohms.

The "S-W" SUPERREGENODE ARTICLES originally appeared in the Oct.-Nov., 1931 and Dec., '31-Jan., '32 issues of
SHORT WAVE CRAFT

Short Wave Stations of the World

All Schedules Eastern Standard Time: Add 5 Hours for Greenwich Mean Time.

Wavelength (Meters)	Frequency (Kilocycles)	Call Letters	Address and Schedule
Broadcasting Stations			
19.56	15.310	W2XAD	General Electric Co., Schenectady, N. Y. Broadcasts 1-3 p.m.; relaying WGY.
19.68	15.210	FYA	Poitouise (Paris), France. 9:30-12:30 a.m. Service de la Radiodiffusion, 103 Rue de Grenelle, Paris.
19.72	15.210	W8XK	Westinghouse Electric & Mfg. Co., East Pittsburgh, Pa. Tues., Thurs., Sat., Sun., 8 a.m. to noon.
19.83	15.120	HVJ	Vatican City (Rome, Italy) Daily, 5:00 to 5:15 a.m. Tokyo, Japan, Irregular.
19.99	15.000	JIAA CM6XJ	Central Tainucu, Cuba. Irregular.
20.50	11.820	XDA	Trens-News Agency, Mexico City, 2:30-3 p.m.
20.95	11.310	G2NM	Gerald Marcuse, Sonning-on-Thames, England. Sundays, 1:30 p.m.
21.50	13.940	University of Bucharest, Bucharest, Roumania, 2-5 p.m., Wed., Sat.
23.00	13.043	TGCA	Guatemala City, Rep. Guatemala, 10 p.m.-midnight
23.35	12.850	W2XD	General Electric Co., Schenectady, N. Y. Antipodal program 9 p.m. Mon. to 3 a.m. Tues. Noon to 5 p.m. on Tues, Thurs. and Sat.
		W2XCU W9XL	Ampere, N. J. Anoka, Minn., and other experimental relay broadcasters.
23.38	12.820	Director General, Telegraph and Telephone Stations, Rabat, Morocco. Sun., 7:30-9 a.m. Daily 5-7 a.m. Telephony.
27.75	10.800	TGW	Guatemala City, Guatemala
29.30	10.250	TI4	Amonio, Cospedes, Marin, Heredia, Costa Rica. Mon. and Wed. 7:30 to 8:30 p.m.; Thurs. and Sat., 9:00 to 10 p.m.
31.10	9.640	HSP2	Broadcasting Service, Post and Telegraph Department, Bangkok, Siam. 9-11 a.m. daily.
31.28	9.590	VK2ME	Amalgamated Wireless, Ltd., 47 York St., Sydney, Australia. Sun., 1-3 a.m. 5-9 a.m., 9:30-11:30 a.m.
		VK3ME	Amalgamated Wireless, Ltd., 47 York St., Melbourne, Australia. Wed. and Sat., 5-6:30 a.m.
31.30	9.580	W3XAU	Byberry, Pa. relays WCAU daily.
31.33	9.570	W1XAZ	Westinghouse Electric & Mfg. Co., East Pittsburgh, Pa. 6 a.m. - 10 p.m. daily.
		SRI	Poznan, Poland. Tues. 1:45-4:45 p.m., Thurs. 1:30-8 p.m.
31.38	9.560	Reichspostzentralamt, 11-15 Schoenherge Strasse (Berlin), Konigswinterhausen, Germany. Daily, 8 a.m. - 7:30 p.m.
31.48	9.530	W2XAF	General Electric Co., Schenectady, N. Y., 5-11 p.m. Skamleboek, Denmark. 2-7 p.m. daily.
31.49	9.520	OXY	Radio Club of Buenos Aires, Argentina.
31.70	9.460	Berne, Switzerland, 3-5:30 p.m.
32.00	9.375	EH90C	Rabat, Morocco, 3-5 p.m. Sunday, and irregularly weekdays.
32.26	9.290	Far East Radio Station, Khabarovsk, Siberia. 5-7:30 a.m.
35.00	8.570	RV15	Poitouise, France, 1-3 p.m. daily.
25.16	11.920	FYA	Westinghouse Electric & Mfg. Co., Pittsburgh, Pa. Tues., Thurs., Sat., Sun., 11 a.m.-4 p.m., and Sat. night Arctic programs. Television, Mon. and Fri. 2:30 p.m., 60 lines, 1200 r.p.m.
25.24	11.880	W8XK	National Broadcasting Co., Downers Grove (Chicago), Ill. 9-10 p.m. daily.
25.26	11.870	VUC	Calcutta, India. 9:45-10:45 p.m.; 8-9 a.m.
25.34	11.840	W2XE	Columbia Broadcasting System, 485 Madison Ave., N. Y., Jamaica, New York. 7:30 a.m. through to 2 a.m. Sundays 8 a.m. to midnight.
		W9XAA	Chicago Federation of Labor, Chicago, Ill. 7-8 a.m., 1-2, 4-5:30, 6-7:30 p.m.
25.42	11.800	VE9GW	W. A. Shane, Chief Engineer, Bowmanville, Canada. Daily, 1 p.m.-10 p.m.
25.47	11.780	VE9DR	Drummondville, Quebec, Canada. Irregular.

Wavelength (Meters)	Frequency (Kilocycles)	Call Letters	Address and Schedule
25.50	11.760	XDA	Trens-News Agency, Mexico City, 3-4 p.m.
25.53	11.730	G5SW	British Broadcasting Corporation, Chelmsford, England. Mon. to Sat., 1:45-7 p.m.
		VE9JR	Winnipeg, Canada. Weekdays, 5:30-7:30 p.m.
30.80	7.530	"El Prado," Robamba, Ecuador. Thurs., 9-11 p.m.
40.00	7.500	"Radio-Touraine," France. Lyons, France. Daily except Sun., 10:30 to 1:30 a.m.
40.20	7.460	YR	Eberswalde, Germany. Mon., Thurs., 1-2 p.m.
40.50	7.410	Nuevo Laredo, Mexico. 9-10 a.m.; 11 a.m.-noon; 1-2; 4-5; 7-8 p.m. Tests after midnight. I.S.W.C. programs 11 p.m. Wed. A.P. 31.
40.70	7.370	X26A	Johannesburg, So. Africa. 9:30 a.m.-2:30 p.m.
40.90	7.320	ZTJ	Doehertz, Germany.
41.46	7.230	DOA	Zurich, Switzerland. 1st and 3rd Sundays at 7 a.m., 2 p.m.
41.50	7.220	HB9D	Budapest, Hungary. 2:30-3:10 a.m., Tu., Thurs., Sat. Budapest Technical School, M.E.C., Budapest. Muskyetem.
		VR1AB	Singapore, S. S. Mon., Wed. and Fri., 9:30-11 a.m.
42.00	7.140	HXX	Bogota, Colombia.
42.70	7.020	EAR125	Madrid, Spain. 6-7 p.m.
42.90	6.990	CT1AA	Lisbon, Portugal. Fridays, 5-7 p.m.
43.00	6.980	EAR110	Madrid, Spain. Tues. and Sat., 5:30 to 7 p.m.; Fri., 7 to 8 p.m.

(NOTE: This list is compiled from many sources, all of which are not in agreement, and which show greater or less discrepancies; in view of the fact that most schedules and many wavelengths are still in an experimental stage; and that wavelengths are calculated differently in many schedules. In addition to this, one experimental station may operate on any of several wavelengths which are assigned to a group of stations in common. We shall be glad to receive later and more accurate information from broadcasters and other transmitting organizations, and from listeners who have authentic information as to call letters, exact wavelengths and schedules. We cannot undertake to answer readers who inquire as to the identity of unknown stations heard, as that is a matter of guesswork; in addition to this, the harmonics of many local long-wave stations can be heard in a short-wave receiver.—EDITOR.)

Wavelength (Meters)	Frequency (Kilocycles)	Call Letters	Address and Schedule
19.15	6.100	W3XAL	National Broadcasting Company, Bound Brook, N.J., Irregular.
		VE9CF	Halifax, N. S., Canada. 6-10 p.m., Tu., Thu., Fri.
49.17	6.095	VE9GW	Bowmanville, Ontario, Canada. Irregular.
49.31	6.980	W9XAA	Chicago Federation of Labor, Chicago, Ill. 6-7 a.m., 7-8 p.m., 9:30-10:15, 11-12 p.m. Int. S.W. Club programs. From 10 p.m. Saturday to 6 a.m. Sunday.
49.40	6.070	VE9CS	Vancouver, B. C., Canada. Fridays before 1:30 a.m. Sundays, 2 and 10:30 p.m.
		Johannesburg, South Africa. 10:30 a.m.-3:30 p.m.
49.46	6.065	SAJ	Motala, Sweden. 6:30-7 a.m., 11 a.m. to 4:30 p.m.
49.50	6.060	W8XAL	Crosley Radio Corp., Cincinnati, O. Relays 6:30-10 a.m., 1-3 p.m., 6 p.m. to 2 a.m. daily. Sunday after 1 p.m.
49.50	6.060	VQ7LO	Imperial and International Communications, Ltd., Nairobi, Kenya, Africa. Monday, Wednesday, Friday, 11 a.m.-2:30 p.m.; Tuesday, Thursday, 11:30 a.m.-2:30 p.m.; Saturday, 11:30 a.m.-3:30 p.m.; Sunday, 11 a.m. - 1:30 p.m.; Tuesday, 3 a.m.-4 a.m.; Thursday, 8 a.m.-9 a.m.
		W3XAU VE9CF	Byberry, Pa. Relays WCAU, Halifax, N. S., Canada. 11 a.m.-noon, 5-6 p.m. On Wed., 8-9; Sun., 6:30-8:15 p.m.
49.50	6.050	Barranquilla, Colombia.
		HKD PK3AN VE9CA W9XF	Sourabaya, Java. 6-9 a.m. Calgary, Alta., Canada. National Broadcasting Co., Downers Grove (Chicago), Ill.
49.67	6.040	Caracas, Venezuela. 7:45-11 p.m. daily ex. Mon.
49.75	6.030	Eiffel Tower, Paris, France. Testing, 6:30 to 6:45 a.m.; 1:15 to 1:30, 6:15 to 6:45 p.m., around this wave.
49.80	6.020	Calgary, Canada.
49.97	6.000	VE9CU	Administration des P. T. Tananarive, Madagascar. Tues., Wed., Thurs., Fri., 9:30-11:30 a.m. Sat. and Sun., 1-3 p.m.
		Vatican City (Rome), 2-2:15 p.m., daily. Sun., 5-5:30 a.m.
50.26	5.970	HVJ	Medellin, Colombia, 8-11 p.m.
50.80	5.900	HKE	Barranquilla, Colombia. 7:45-10:30 p.m. Mon., Wed., Sat.; 2-4, 7:45-8:30 p.m. Sun. Elias J. Pellet.
51.40	5.835	HKD	Winnipeg, Canada.
52.50	5.710	VE9CL	Columbus, Ohio.
54.02	5.550	W8XJ	Prague, Czechoslovakia. 1-3:30 p.m., Tues. and Fri.
58.00	5.170	OKIMPT	Bandoeng, Java.
		PMY PMB W2XAV	Sourabaya, Java. Radio Engineering Laboratories, Inc., Long Island City, N. Y.
60.30	4.975	Elgin, Ill. (Time signals.) Washington, D. C. Chicago, Ill.
62.56	4.795	W9XAM W3XZ W9XL	Doehertz, Germany. 6-7 p.m., 2-3 p.m., Mon., Wed., Fri.
67.65	4.430	DOA	Vienna, Austria. Sun., first 15 minutes of hour from 1 to 7 p.m.
70.00	4.280	OHK2	Far East Radio Station, Khabarovsk, Siberia. Daily, 3-9 a.m.
70.20	4.273	RV15	Constantine, Tunis, Africa. Mon. and Fri.
80.00	3.750	F8KR	(Prato Smeraldo), Rome, Italy. Daily, 3-5 p.m.
82.90	3.620	DOA	Doehertz, Germany. (Television.)
81.24	3.560	OZ7RL	Copenhagen, Denmark. Tues. and Fri. after 6 p.m.

Experimental and Commercial Radio-Telephone Stations

5.83	51,400	W2XBC	New Brunswick, N. J.
7.05	42,530	Berlin, Germany. Tues. and Thurs., 11:30-1:30 p.m. Telefunken Co.
8.67	34,600	W2XBC	New Brunswick, N. J.
9.68	31,900	W8X1	Pittsburgh, Pa.
10.79	27,800	W6XD	Palo Alto, Calif. M. R. T. Co.
11.55	25,960	G5SW	Chelmsford, England. Ex-perimental, Sat.
11.67	25,700	W2XBC	New Brunswick, N. J.

(Continued on opposite page)

Short Wave Stations of the World

(Continued from opposite page)

Wavelength (Meters)	Frequency (Kilocycles)	Call Letters	Address and Schedule	Wavelength (Meters)	Frequency (Kilocycles)	Call Letters	Address and Schedule	Wavelength (Meters)	Frequency (Kilocycles)	Call Letters	Address and Schedule	
12.48	24,000	W6XQ	San Mateo, Calif. (Several experimental stations are authorized to operate on non-exclusive waves of a series, both above this and down to 4 meters.)	16.82	17,830	PCV	Kootwijk, Holland. 9:40 a.m. Sat.	21.98	12,000	FZG	Salgon, Indo-China. Time signals, 2-2:05 p.m.	
			Vienna, Austria, Mon., Wed., Sat.	16.87	17,780	W8XK	Westinghouse Electric and Mfg. Co., East Pittsburgh, Pa.	25.10	11,915	KKQ	Hollnas, Calif.	
13.02	21,510	W8XK	Pittsburgh, Pa.	17.00	17,610		Ship, Phones to Shore: W8BN, "Leviathan"; GFVV, "Majestic"; GLSQ, "Olympic"; GDLJ, "Homeric"; GMJQ, "Heizenland"; work on this and higher channels.	25.65	11,680	YVQ	Maracay, Venezuela. (Also broadcasts occasionally)	
14.00	21,320	W2XDJ	Deal, N. J. And other experimental stations.	17.25	17,380		Tokio, Japan.	25.68	11,670	KIO	Kahulu, Hawaii.	
14.01	21,100	WLO	American Telephone & Telegraph Co., Lawrence, N. J., transatlantic phone.	17.34	17,300	W2XK	Schenectady, N. Y. Tues., Thurs., Sat. 12 to 5 p.m. General Electric Co.	26.00	11,530	CGA	Drummondville, Canada.	
14.15	21,130	LSM	Monte Grande, Argentina. (Hurlingham), Buenos Aires, Argentina.			W8XL	Dayton, Ohio.	26.10	11,190	GBK	Bedmin, England.	
14.27	21,020	LSN	Podlebrady, Czechoslovakia.			W6XAJ	Oakland, Calif.	26.15	11,170	IBDK	S.S. "Elettra," Marconi's yacht.	
11.28	21,000	OK1	Monte Grande, Argentina. Telephony.	17.52	17,110	W00	Deal, N. J. Transatlantic phone.	26.22	11,435	DHC	Nauen, Germany.	
14.17	20,710	LSY	Monte Grande, Argentina. Telephony with Europe.			W2XDO	Ocean Gate, N. J. A. T. & T. Co.	26.44	11,310	DAN	Norddeich, Germany. Time signals, 7 a.m., 7 p.m. Deutsche Seewarte, Hamburg.	
11.50	20,680	LSN	Buenos Aires. Telephony with U. S.	17.55	17,080	GBG	Rugby, England.	27.30	10,980	ZLW	Wellington, N. Z. Tests 3-8 a.m.	
		FSR	Paris-Salgon phone.	18.40	16,300	PCL	Kootwijk, Holland. Works with Bandoeng from 7 a.m.	28.20	10,630	PLR	Bandoeng, Java. Works with Holland and France weekdays from 7 a.m.; sometimes after 9:30.	
11.54	20,820	PMB	Bandoeng, Java. After 4 a.m.			WLO	Lawrence, N. J.	28.14	10,540	WLO	Lawrence, N. J.	
11.62	20,500	W9XF	Chicago, Ill.	18.50	16,200	FZR	Salgon, Indo-China.	28.80	10,410	VLK	Sydney, Australia. 1-7 a.m.	
11.89	20,110	DWG	Nauen, Germany. Tests 10 a.m.-3 p.m.	18.56	16,150	GBX	Rugby, England.			PDK	Kootwijk, Holland.	
15.03	19,950	LSG	Monte Grande, Argentina. From 7 a.m. to 1 p.m. Telephony to Paris and Nauen (Berlin).	18.68	16,060	NAA	U. S. Navy, Arlington, Va. Time signals, 11:57 to noon.			KEZ	Hollnas, Calif.	
		DIH	Nauen, Germany.	18.80	15,950	PLG	Bandoeng, Java. Afternoons.	28.86	10,380	LSY	Buenos Aires, Argentina.	
15.07	19,906	LSG	Monte Grande, Argentina. 8-10 a.m.	18.90	15,860	FTK	St. Assise, France. Telephony.	29.51	10,150	GBX	Rugby, England.	
15.10	19,850	WMI	Deal, N. J.	18.93	15,780	JIAA	Tokio, Japan. Up to 10 a.m. Beam transmitter.			DIS	Nauen, Germany. Press (code) daily; 6 p.m., Spanish; 7 p.m., English; 7:50 p.m., German; 2:30 p.m., English; 5 p.m., German. Sundays: 9 p.m., Spanish; 7:50 p.m., German; 9:30 p.m., Spanish.	
15.12	19,830	FTD	St. Assise, France.	19.04	15,750	Chi-Hua, Salgon. Indo-China. Telephony.	30.15	9,950	GBU	Rugby, England.	
15.20	19,720	EAQ	Madrid, Spain.	19.60	15,300	OXV	Lynghy, Denmark. Experimental.	30.30	9,890	LSN	Buenos Aires, phone to Europe.	
15.45	19,400	FRO, FRE	St. Assise, France.			W6XAL	Konkawustarhausen, Germany. After 7 a.m.			LSA	Buenos Aires.	
15.50	19,350	Nancy, France. 4 to 5 p.m.	20.65	14,530	LSA	Westminster, Calif.	30.64	9,790	GBW	Madrid, Spain.	
15.55	19,300	FTM	St. Assise, France. 10 a.m. to noon.	20.70	14,480	W8XK	Buenos Aires, Argentina.	30.75	9,750	GBW	Rugby, England.
15.58	19,210	DFA	Nauen, Germany.			GBW	East Pittsburgh, Pa.			WNC	Aken, France. Tues. and Fri., 3 to 1:15 p.m.	
15.60	19,220	WNC	Deal, N. J.	20.80	14,420	WNC	Radio Section, General Post Office, London, E. C. 1.	30.90	9,700	WMI	Deal, N. J.	
15.91	18,820	PLE	Bandoeng, Java. 8:40-10:10 a.m. Phone service to Holland.	21.17	14,150	KKZ	Rugby, England.	30.93	9,600	LQA	Buenos Aires.	
16.10	18,620	GBJ	Bodmin, England. Telephony with Montreal.	22.38	13,400	WND	Hollnas, Calif.	31.23	9,600	LGN	Bergen, Norway.	
16.11	18,620	GBU	Rugby, England.	23.46	12,780	GBG	Deal Beach, N. J. Transatlantic telephony.	32.13	9,330	CGA	Drummondville, Canada.	
16.33	18,370	PMC	Bandoeng, Java.	24.11	12,290	GBU	Deal Beach, N. J. Transatlantic telephony.	32.13	9,330	CGA	Rugby, England. Sunday 2:30-5 p.m.	
16.35	18,350	WND	Deal Beach, N. J. Transatlantic telephony.	24.16	12,250	FTN	Rugby, England.	32.21	9,310	GBC	Deal, N. J.	
16.38	18,310	GBS	Rugby, England. Telephony with New York. General Postoffice, London.			GBS	Rugby, England.	32.40	9,250	GBK	Deal, N. J.	
		FZS	Salgon, Indo-China. 1 to 3 p.m. Sundays.			PLM	St. Assise (Paris), France. Works Buenos Aires, Indo-China and Java. On 9 a.m. to 1 p.m. and other hours.	32.50	9,230	FL	Deal, N. J.	
16.14	18,210	FRO, FRE	St. Assise, France.	21.80	12,090	Rugby, England.			W3XE	S.S. "Leviathan."	
16.50	18,170	CGA	Drummondville, Quebec, Canada. Telephony to England.	21.89	12,045	NAA	Bandoeng, Java. 7:45 a.m.	33.98	8,810	WSBN	Schenectady, New York.	
16.57	18,100	GBK	Bodmin, England.			FQD, FQE	Rugby, England. Transatlantic phone to Deal, N. J. (New York).	34.50	8,690	W2XAC	Ampere, N. J.	
		W9XAA	Chicago, Ill. Testing, mornings.			NSS	St. Assise, France.	34.68	8,650	W9XL	Chicago.	
16.61	18,050	KQJ	Hollnas, Calif.				Tokio, Japan. 5-8 a.m.			W3XE	Baltimore, Md. 12:15-1:15 p.m., 10:15-11:15 p.m.	
16.80	17,870	PLF	Bandoeng, Java ("Radio Malabar").				Arlington, Va. Time signals, 11:57 to noon.			W2XV	Long Island City, N. Y.	
		W2XAO	New Brunswick, N. J.				Annapolis, Md. Time signals, 9:57-10 p.m.			W8XAG	Dayton, Ohio.	

(Continued on next page)

"Star" Short Wave Broadcasting Stations

The following stations are reported regularly by many listeners, and are known to be on the air during the hours stated. You should be able to hear them on your own short-wave receiver. All times E.S.T.

G5SW, Chelmsford, England. 25.53 meters. Monday to Saturday 1:45 p.m. to 7:00 p.m. Signs off with the midnight chimes of Big Ben in London.

HVJ, Vatican City. Daily, 5:00 to 5:15 a.m. on 19.83 meters; 2:00 to 2:15 p.m. on 50.26 meters; Sunday 5:00 to 5:30 a.m. on 50.26 meters.

13RO, Rome, Italy. Daily on 80 meters, from 3:00 to 5:00 p.m. Woman announcer.

VK2ME, Sydney, Australia. 31.28 meters. Sunday morning from 1:00 to 3:00 a.m.; 5:00 to 9:00 a.m.; and 9:30 to 11:30 a.m.

VK3ME, Melbourne, Australia. 31.28 meters. Wednesday and Saturday, 5:00 to 6:30 a.m.

FYA, Pointoise, France. On 19.68 meters, 9:30 a.m. to 12:30 p.m.; on 25.16 meters, from 1:00 to 3:00 p.m.; and on 25.63 meters from 4:00 to 6:00 p.m.

Konigs-Wusterhausen, Germany. On 31.38 meters, daily from 8:00 a.m. to 7:30 p.m.

HKD, Barranquilla, Colombia. On 50 meters, Monday, Wednesday and Friday, 8:00 to 10:30 p.m.; Sunday, 7:45 to 8:30 p.m.

VE9GW, Bowmanville, Ontario, Canada. 25.4 meters, from 1:00 to 10:00 p.m.

HRB, Tegucigalpa, Honduras. 48.62 meters. Monday, Wednesday, Friday, and Saturday, 5:00 to 6:00 and 9:00 to 12:00 p.m.

TI4, Heredia, Costa Rica, Central America. 29.3 meters. Monday and Wednesday, 7:30 to 8:30 p.m.; Thursday and Saturday, 9:00 to 10:00 p.m.

XDA, Mexico City. 25.5 meters. Daily, 3:00 to 4:00 p.m.

F3ICD, Chi-Hoa, French Indo-China. 49.1 meters. Daily from 6:30 to 10:30 a.m.

RV15, Khavarovsk, Siberia. 70.2 meters. Daily, from 3:00 to 9:00 a.m.

Wavelength (Meters)	Frequency (Kilocycles)	Call Letters	Address and Schedule
		W4XG W3XX	Miami, Fla. Washington, D. C. And other experimental stations.
34.74	8,630	W00	Deal, N. J.
35.02	8,550	W2X00	Ocean Gate, N. J.
35.50	8,450	W00 PRAG	Ocean Gate, N. J. Porto Alegre, Brazil. 8:30-9:00 a.m.
36.92	8,120	PLW	Banjoeng, Java.
37.02	8,100	EATH JIAA	Vienna, Austria. Mon. and Thurs., 5:30 to 7 p.m. Tokyo, Japan. Tests 5-8 a.m.
37.80	7,930	DOA	Duerbritz, Germany. 1 to 3 p.m. Reichpostzentramt, Berlin.
38.00	7,890	VPD JIAA	Suva, Fiji Islands. Tokio, Japan (Testing).
38.30	7,830	PDV	Kootwijk, Holland, after 9 a.m.
38.60	7,770	FTF PCK	Ste. Assise, France. Kootwijk, Holland. 9 a.m. to 7 p.m.
39.15	7,660	FTL	Ste. Assise.
39.40	7,610	HKF	Bogota, Colombia. 8-10 p.m.
39.71	7,520	CGE	Calgary, Canada. Testing, Tues., Thurs.
43.70	6,860	KEL	Bollinas, Calif. Radio Vitus, Paris, France. 4-11 a.m., 3 p.m.
43.80	6,810	CFA	Drummondville, Canada.
44.10	6,753	WND	Deal, N. J.
41.99	6,660	F8KR HKM	Constantine, Algeria, Mon., Fri., 5 p.m. Bogota, Colombia. 9-11 p.m.
45.50	6,560	RFN	Moscow, U.S.S.R. (Russia) 2 a.m.-4 p.m.
46.05	6,515	W0D	Deal, N. J.
62.80	4,770	ZL2XX	Wellington, New Zealand.
63.00	4,760	Radio LL	Paris, France.
63.13	4,750	W00	Ocean Gate, N. J.
63.79	4,700	W1XAB	Portland, Me.
72.87	4,116	W0D	Deal, N. J.
74.72	4,105	NAA	Arlington, Va. Time signals, 9:57-10 pm., 11:57 a.m. to noon.
92.50	3,256	W9XL	Chicago, Ill.
92.5-94.9	3,244-3,160		KFR, WJE, City of Seattle, Wash., Light Dept. City of Los Angeles, Calif., Water Dept.
94.20	3,184	KQS, KQT	Samarang, Java. Deal, N. J.
95.00	3,156	PK2AG	
96.03	3,121	W0D	

Wavelength (Meters)	Frequency (Kilocycles)	Call Letters	Address and Schedule
97.53	3,076	W9XL	Chicago, Ill. Mottum, Sweden. 11:30 a.m.-noon, 4-10 p.m.
98.95	3,030	VE5AR	Saskatoon, Sask., Canada.
Airport Stations			
53.25	5,630	WQDP	Atlanta, Ga.
56.00	3,490	WSDE WSDB KGUK KGUF KGUC KGUL KGUG KGUA	Tuscaloosa, Ala. Jackson, Miss. Shreveport, La. Dallas, Tex. Fort Worth, Tex. Ahlens, Tex. Big Springs, Tex. El Paso, Tex. (Southern Air Transport Lines.) Aurora, Ill. Iowa City, Iowa. Des Moines, Iowa. Omaha, Neb. Lincoln, Neb. North Platte, Neb. Cheyenne, Wyo. Rock Springs, Wyo. Salt Lake City, Utah. Elko, Nevada. Beno, Nevada. Oakland, Calif. Boise, Idaho. Pasco, Wash. (Boeing Air Lines.)
53.53	5,600	WQDU	Newark, N. J.
91.52	3,170	KQQ KQM KMP KRF KMR KQE KQC KQD KKO KJE KFO KRA KDD	Camden, N. J. Harrisburg, Pa. Pittsburgh, Pa. Columbus, Ohio. Indianapolis, Ind. St. Louis, Mo. Tulsa, Okla. Amarilla, Tex. Albuquerque, N. M. Kingman, Ariz. Las Vegas, Nev. Los Angeles, Calif. Wichita, Kan. Kansas City, Mo. (Transcontinental Air Transport.)
54.00	5,560	WAEF	Newark, N. J.
96.77	3,100	WAEW WAEC WAEB WAEA KGTR KSY KSW KSX KGPL KGJT KSI KGTD KST	Camden, N. J. Harrisburg, Pa. Pittsburgh, Pa. Columbus, Ohio. Indianapolis, Ind. St. Louis, Mo. Tulsa, Okla. Amarilla, Tex. Albuquerque, N. M. Kingman, Ariz. Las Vegas, Nev. Los Angeles, Calif. Wichita, Kan. Kansas City, Mo. (Transcontinental Air Transport.)

Wavelength (Meters)	Frequency (Kilocycles)	Call Letters	Address and Schedule
6.89	43,500	W9XD W3XAD	Milwaukee Journal, Mil.waukee, Wis. Camden, N. J. (Other experimental television permits: 48,500 to 50,300 k.c., 43,000-46,600 k.c.)

Wavelength (Meters)	Frequency (Kilocycles)	Call Letters	Address and Schedule
124.2	2,416	WPDI WPDE KGPP WPDJ WPDS WPDA	Columbus, Ohio. Louisville, Ky. Minneapolis, Minn. Passaic, N. J. St. Paul, Minn. Tulare, Calif.
124.5	2,410	WCK	WRDR. WMO. Detroit Belle Isle, Grosse Pointe, Highland Park, Mich. Washington, D. C. San Francisco, Calif. Vallejo, Calif. Hartmore, Md., Police Dept. Chicago, Ill. Amberg, N. J. Kokomo, Ind.
125.1	2,398	W9XL W2XCU WPDT	Chicago, Ill. Amberg, N. J. Kokomo, Ind.

Wavelength (Meters)	Frequency (Kilocycles)	Call Letters	Address and Schedule
101.7 to 105.3	meters—2,850	W1XAV	Short Wave & Television Corp., Boston, Mass. 1-2, 7:30 to 10:30 p.m. daily ex. Sun. Works with W1XAU 10-11 p.m.
		W2XR	Radio Pictures, Inc., Long Island City, N. Y. 4 to 10 p.m. exc. Sundays. Silent 7-7:30 Sat.
105.9	2,833	W9XR W6XAN W7XAB	Chicago, Ill. Los Angeles, Calif. Spokane, Wash. to 2,850 kc.
105.3 to 109.1	meters—2,750	W2XAB	Columbia Broadcasting System, 485 Madison Ave., N. Y. 2-6, 8-11 p.m. On Sat. and Sun. to 10 p.m. Works with W2XE on 18.99 meters.
		W2XBD W9XAA W9XC	Long Island City, N. Y. Chicago, Ill. West Lafayette, Ind.
108.8	2,758	VE9CI	London, Ont., Canada, to 2,200 kc.
136.4 to 142.9	meters—2,100	W2XBS	National Broadcasting Co., New York, N. Y. 1,200 R.P.M., 60 lines deep, 72 wide, 2-5 p.m., 7-10 p.m. ex. Sundays.
		W2XR	Radio Pictures, Inc., Long Island City, N. Y. 48 and 60 line. 5-7 p.m.
		W3XAD	R. C. A.-Victor Co., Inc., Camden, N. J.
		W2XCW W8XAV	Schenectady, N. Y. Pittsburgh, Pa. 1,200 R.P.M., 60 holes, 1:30-2:30 p.m., Mon., Wed., Fri.
142.9 to 150	meters—2,000 to 2,100 kc.	W9XAP W2XAP W2XCR	Chicago, Ill. Jersey City, N. J. Jersey City, N. J. 3-5, 6-9 p.m. ex. Sun.
		W3XK	Wheaton, Maryland, 10:30 p.m.-midnight ex. Sun. Works with W3XJ.
		W2XCD	Passaic, N. J. 2-3 p.m. Tues., Thurs., Sat.
142.9 to 150	meters—2,000 to 2,100 kc.	W9XAO W9XAA	Chicago, Ill. Chicago, Ill.

Wavelength (Meters)	Frequency (Kilocycles)	Call Letters	Address and Schedule
121.5	2,470	KGOZ WRDQ	Cedar Rapids, Ia. Toledo, Ohio.
122.0	2,458	WPDG	Youngstown, Ohio.
122.3	2,452	WRBH KGPP WPKP KGPH WPEE WPEF WPDF WDA WDPD	Cleveland, Ohio. Portland, Ore. Milwaukee, Wis. Oklahoma City, Okla. New York, N. Y. New York, N. Y. New York, N. Y. Flint, Mich. Miami, Fla. Philadelphia, Pa. Lansing, Mich. Portland, Mich.
122.4	2,450	WPEE WPEF WPDF WDA WDPD	New York, N. Y. New York, N. Y. New York, N. Y. Flint, Mich. Miami, Fla. Philadelphia, Pa. Lansing, Mich. Portland, Mich.
123.0	2,440	WPEE WPEF WPDF WDA WDPD	New York, N. Y. New York, N. Y. New York, N. Y. Flint, Mich. Miami, Fla. Philadelphia, Pa. Lansing, Mich. Portland, Mich.
123.9	2,422	W3XB WMJ KGPE	Buffalo, N. Y. Kansas City, Mo. (Mo. State).

Police and Fire Stations

The Australian postal authorities are planning the building of a special short-wave reception plant with multiple antennas, in order to transmit all the European radio programs through the Australian broadcast stations.

A Chinese telegraphic transmitter is radioing daily the latest news of the Sino-Japanese war. The broadcasts are on the 37-64-meter wave, with 20 kilowatts.

The Philips short-wave station PCJ, Eindhoven, has stopped its broadcasts, because of technical alterations. Operation will be resumed in May, 1932.

The new Indo-Chinese station "Radio-Saigon" operates with 12 KW on the 25.465-meter wave. The broadcasts occur every Friday from 15.30 until 15.50 o'clock. Reception observations are requested by the Cie. Française de Radiophonie, 18 Rue Boissy d'Anglas, Paris.

The Siamese short-wave station HSP2, Bangkok, is now transmitting on the 41 meter wave with 2½ KW.—*Der Funken.*

ULTRA-SHORT WAVE RADIO IN BERLIN

For almost a year three ultra-short wave transmitters have been operating in Berlin. It has been possible to assemble numerous results of importance for further research. First, it has appeared that the failures resulting, because ultra-short waves are somewhat harder to tune in, can be eliminated by a suitable increase of the transmitter power; but that, on the other hand, these waves cannot be used for bridging a greater distance than some 10 to 15 kilometers (6 to 9 miles). The seven-meter (23 ft.) wave has shown itself the most suitable. The greatest possibilities of development lie in the field of television. The frequency band needed for this is about 100,000 cycles. It cannot be put on the radio broadcast band, since this would take up a sixth of the entire available field. The solution is furnished by the ultra-short waveband; where, on the seven-meter wave (40,000,000 cycles), the 100,000 cycles make up only one-four hundredth of the total range.

The German Postoffice Department is already said to have ordered a large ultra-short wave transmitter, which is to be put in operation in Berlin.

ULTRA-SHORT WAVES IN THE GERMAN MUSEUM

The Wireless Telegraphy Section of the German Museum has lately been enriched by a very valuable demonstration apparatus for ultra-short waves, transmitter and receiver for 14-centimeter (5.6 inch) waves, a gift of the South German Telephone Apparatus, Cable, and Wire Works (TKD, or "Tekade") in Nuremberg. With the new short-wave apparatus particularly the optical properties of short waves, such as reflection, refraction, the production of stationary waves, and polarization, can be presented with surprising exactitude. Like a light ray, the ultra-short wave is diverted by a prism, in this case consisting of wood, and is reflected by a metal mirror.

HIGH-POWER HUNGARIAN SHORT WAVE STATION

The Hungarian postal authorities have decided to build in Budapest a big short-wave station, to be ready by the end of this year. The station, which is to have a power extraordinary for short waves (25 kilowatts), is to be built according to the most modern ideas and to be suited to reach the entire world.

Short Wave Question Box

Super-Converter Trouble

F. E. Collins, Schenectady, N. Y., writes:
 (Q.) I have built a super-converter using a '27 oscillator and a '24 detector. The antenna is capacitively coupled to the detector coil. I am having trouble with signals coming in on the second beat. Can this interference be

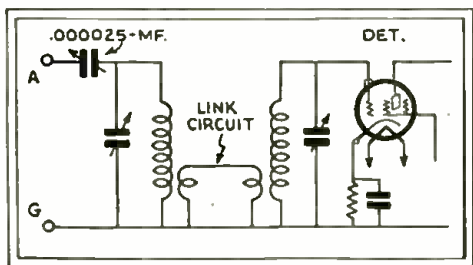

How to use a band-pass filter on super-converter to improve tuning.

eliminated without resorting to the use of a tuned R.F. stage?

(A.) A band-pass filter of two sections connected ahead of the first detector will easily eliminate your trouble, which is termed *image frequency* interference. The simplest arrangement is shown in these columns. The section in the antenna circuit should have the same number of turns as the detector section. The "link" circuit coils should have ONE turn of wire not smaller than No. 16 or 18. The two tuning condensers may be ganged if desired.

(Q.) The broadcast receiver with which this converter is used has three R.F. stages. Would it be advisable to add a screen grid stage in the converter tuned to the broadcast receiver?

(A.) No. If you want to add another tube use it as a signal frequency amplifier.

Choke in 12,500 Mile Receiver

Earl L. Stout, Kansas City, Mo., writes as follows:

(Q.) In the 12,500 mile (?) receiver on page 258, Dec.-Jan. issue, an R.F. choke is mentioned but it is not shown in the circuit. Where does it go?

(A.) The R.F. choke should be connected from the P terminal on the A.F. transformer to the stator of the regeneration condenser.

(Q.) How about a coil to go higher than the 125 meter limit?

(A.) 45 to 50 turns of No. 24 on the same size forms as the other coils will reach up to about 200 meters. Just a word of advice:—DO NOT use orange shellac or any other kind if you want to keep the losses low. Recently, I was called upon to look over a set which had failed to give "even a peep". All of the coils had been painted with shellac. A new set of coils without the dope brought in signals to the satisfaction of the builder.

Coil and Condenser Query

Fred Krustel, San Bernardino, Calif., asks:
 (Q.) Kindly print a circuit using Hammarlund coils and .00014 mf. condensers?

(A.) A circuit using these parts was published in June-July, 1930, issue, Page 67.

Range and Tubes to Use?

Thomas Ramsey, Calhoun, S. C., wants to know:

(Q.) What changes are necessary to use 201A tubes in the circuit shown on page 258, Dec.-Jan. issue?

(A.) The only changes necessary is to employ a 6-volt storage battery and use a filament rheostat of 4 to 6 ohms in place of the 20 ohms specified.

(Q.) With this circuit would it be possible to obtain "consistent" 12,500 mile reception?

(A.) Positively no. Even a 12-tube superhet could not do this.

Edited by

R. William Tanner

Coil Data for .00035 M.F.

C. Martyn, St. Thomas, Ont., Canada, asks:
 (Q.) Can you give me coil data to cover short waves with .00035 mf. condenser? The coil diameter is 2 1/2 inches.

(A.) Two coils will be needed, one with 3 turns for the grid coil and 3 for tickler. The other will have about 18 turns for grid and 9 for tickler. Spacing the turns slightly is advised. No. 24 D.C.C. wire is ideal for this type of coil.

Percentage of Modulation

R. B. McIntire, Niles, Ohio, wants to know:
 (Q.) What percentage of modulation can be obtained using 210 tubes in a T.G.T.P. circuit with 250's as modulators?

(A.) The percentage of modulation will be 20 to 30 per cent when adjustments are so made as to prevent "wobulation" or frequency modulation.

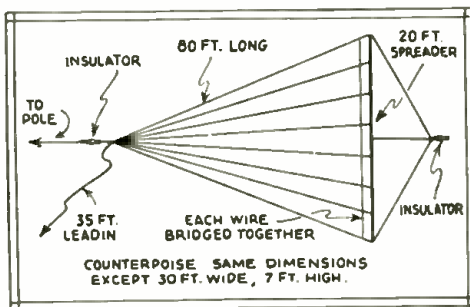

Details of 160-meter antenna.

160 Meter Antenna Data

H. H. Harvey, Glens Falls, N. Y., desires the following information:

(Q.) The new phone regulations states that I must operate in the 160 meter band. Can you give dimensions and diagram of an antenna to use.

(A.) I am going to give you the data on the antenna system which I used a few years ago at SCMF. With this antenna and a pair of 5 watt oscillators, I worked a "ham" in Centralia, Wash., as well as other stations 1,000 to 1,500 miles away consistently. The antenna consisted of 8 number 14 wires "fanned" out to a 20-foot spreader. Each wire was 80 feet long. The counterpoise also had 8 wires but was fanned out to 30 feet, 7 feet above the ground. The far end of the antenna had a height of 62 feet sloping to 30 feet high at the shack end. A diagram is given in these columns. The length of the counterpoise leadin was approximately 15 feet. Pyrex or good glass insulators are recommended.

(Q.) Will it be necessary to employ a higher oscillator tuning capacity in the 160 meter band than is used at 85 meters?

(A.) It will not be exactly necessary, since variations in plate and filament voltages have less effect upon the frequency in this band; however, it would be better to use say an .0005-mf. variable in parallel with a GOOD MICA .00025-mf., fixed condenser.

(Q.) What antenna current may I expect from a pair of 210's in parallel when operated in the 160 meter band? The plate voltage is 500 V.

(A.) I assume the 210's will be in an oscillator circuit in which case a current of 2 to 3 amperes is possible, providing a high capacity antenna is employed. If you do not obtain more than a few tenths of an ampere, do not be discouraged since the ammeter may be in a low current part of the antenna system.

Best Antenna

F. B. Umpleby, Trenton, N. J., asks:
 (Q.) What is the best type of antenna for short wave use?

(A.) There is no "best" antenna for short waves unless you desire reception from one direction only, in which case a dipole is recommended. A single wire 10 to 100 feet long is generally OK.

Receiver Coil Data

A. J. Regan, Pittsburgh, Pa., writes:
 (Q.) I am building a set but have lost the coil data. Can you give turns and wire size for use on S-M forms? The tuning condenser is .00015-mf.

(A.) No. 22 enamel for all grid windings except the 200 meter band which, due to the greater number of turns required, will have to be wound with No. 24 enamel. No. 30 (any insulation) is used for ticklers.

Grid Tickler		Space the grid coils for the	
20	7	6	20, 40 and 80 meter bands,
40	13	7	over the entire winding space.
80	25	9	
200	50	20	

Adjusting I.F. Transformers

Walter Lasocki, Detroit, Mich., wants to know:
 (Q.) What are the sizes of coils and wire used for the oscillator and I.F. transformers in the receiver described on Page 250, Dec.-Jan. issue?

(A.) As this is a manufactured set, no data is available.

(Q.) What is a good method of adjusting I.F. transformers to exactly 480 K.C.?

(A.) There is only one method and that is to employ an accurate oscillator which is a fairly expensive instrument. It would be far cheaper to send the set to a laboratory for adjustment.

Choke Data

R. von Riegers, Squantum, Mass., writes:
 (Q.) What is the value of the R.F. chokes used in the receiver, page 26 of the June-July issue?

(A.) Chokes having an inductance of 85 M.H. will give good results. If distributed capacity is low, even chokes of less inductance can be employed.

Tuned R.F. Stage

W. J. Bone, Jr., Atlanta, Ga., asks:
 (Q.) For a diagram of a tuned R.F. stage to use with the circuit on page 258, Dec.-Jan. issue.

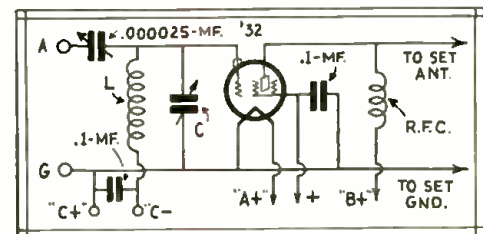

How to connect a tuned R.F. stage ahead of receiver.

(A.) The circuit is given in these columns. A 232 tube is used. The lead from the plate connects directly to the antenna posts on the 2 tube set, the antenna condenser then acting as a coupling condenser. The coils L will be exactly like the grid coils in the set. Likewise, the condenser C will have the same capacity as the set tuning condenser.

(Q.) Would the addition of an R.F. choke in the detector plate circuit improve results?

(A.) Such a choke should be incorporated in order to keep R.F. currents out of the audio amplifier.



THE GEM of the Short Waves



THIS 3-screen grid tube Short Wave set uses three of the NEW UX232 screen grid tubes in a new balanced circuit that brings maximum selectivity and sensitivity with loud speaker volume. The circuit consists of one stage of R.F. coupled into a non-radiating detector and fed into the last 232 which is used as an audio amplifier. This combination eliminates ALL dead spots and does away with the antenna tuning control making the set, really ONE DIAL.

Completely shielded in a NON-MAGNETIC all metal black crackle finish case. Space is provided for inside the cabinet for all batteries. No messy wires to mar the appearance of your receiver.

A TRIUMPH IN ENGINEERING.

Columbia One-Tube Screen Grid Set similar to above in all metal black crackle finish case. Completely assembled and wired less tubes and batteries..... **\$7.45**

1-UX232 Tube\$1.10

Set of Batteries.....\$2.10

Complete with Tubes and Batteries.....\$10.25

Completely assembled and wired; less tubes and batteries..... **\$13.75**
 Set of batteries..... **3.95**
 Set of matched tubes..... **3.25**
 Complete with tubes and batteries **19.95**

• **C O L U M B I A** •
 SPECIALTY COMPANY
 925 Westchester Avenue, Dept. K
 New York, N. Y.

Experiments With Ultra Short Waves

By ROBERT KRATZENSTEIN

(Continued from page 27)

force of the oscillation-circuit coil; in other words, they are to be coupled to the coil as little as possible, because otherwise they withdraw energy from the oscillation circuit.

After learning these things I was able to improve my oscillation producer also. The hook-up of Fig. 2b was abandoned and the push-pull hook-up of Fig. 10 selected. Fig. 11 reproduces the entire hook-up, with some unimportant simplifications. The two RE89 (German) tubes are former power tubes, whose filaments

are connected in parallel. The oscillation circuit was composed of two equally large wire loops (tinned copper wire, No. 15), forming a circle 110 mm. (4½ inches) in diameter. It proved necessary to put small condensers between grids and plates of the tubes; these, in the form of small brass sheets about 0.2-mm. (0.8-inch) apart, were clamped fast on the tube prongs (grid and plate). The capacity of each condenser was calculated as about 6 mmf. Although these condensers were only to do temporary service, I have kept them; since they did not change their capacities themselves (of course I could not touch them). The choking is effected by small "air chokes" of the above-described kind, with ¼-inch diameter and 7 to 10 turns. The size of the chokes remained the same for further experiments; because the wavelength was not changed later (or only to an unimportant degree).

In hook-up 11, the striking thing is the peculiar way of running the filament leads, which, however, corresponds to the reality. First, I had to run the filament wires to approximately the middle of the coil and then run them vertically downward. With a direct drop of the wires from the tube socket, the lower half of the oscillation coil would have an inductive effect on the filament wires, and oscillation would cease.

The plate current is taken from the D.C. network over two metal filament lamps, likewise the current for the buzzer.

The plate current, at 100 volts, amounts to 8 milliamperes when oscillating and 10 milliamperes when not oscillating, (with antenna coupled, or 6.5 or 10 milliamperes without an antenna). A little neon-lamp tester, coupled to the oscillating circuit, did not come in the least to glowing; likewise in the tuned detector circuit only a very small current could be obtained, so slight is the energy. But for my receiving experiments in the house it is sufficient. The entire apparatus was built into a thin-walled cabinet of wood and then set on four little rubber sponges, in order to avoid the vibration caused by passing trucks.

The horizontal dipolar antenna I have assembled out of three parts. The middle part is a copper wire inside the housing, forming the coupling coil (one winding of 53 mm. (2 inches) diameter, lying concentrically within the oscillation coil.

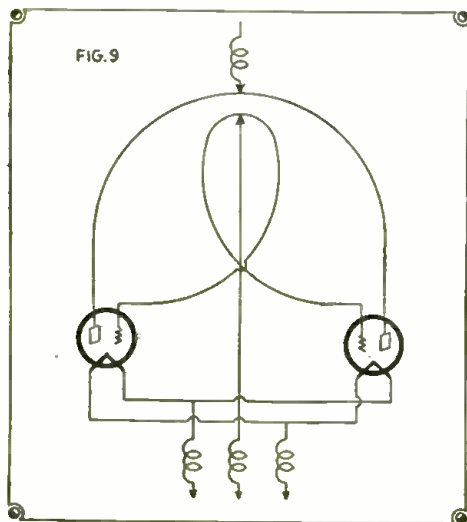

Push-pull hook-up II.

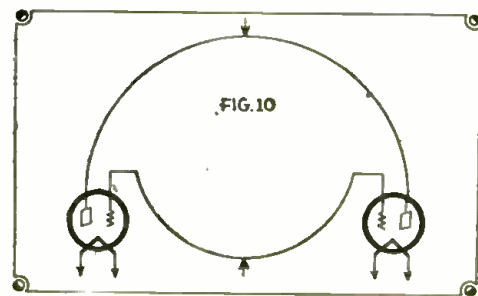

Push-pull hook-up III.

The two true antenna rods consist of 10 mm. (3/8-inch) brass pipe, fastened by screws to the middle part, from which they can easily be taken off. The length of the middle part is 120 mm. (4 3/4-inch); length of wire 280 mm. (11 inches); and that of each antenna rod 280 mm. With a longer antenna oscillation soon stops. In Fig. 12 one sees the antenna rods, each 12 cm. (4 3/4 inches) long projecting out of the cabinet at front and back and at the right end also one of the two tubes.

When the picture was taken (1928), I still had battery heating and a special house-line connection; later I have found equipment for D.C. line heating. By chance, a 25-cp. carbon-filament lamp for 220 volts passed exactly the current which my two RE89 tubes need; making the change very simple. The filament current from the light-socket is not filtered, but the plate current is filtered (5 henries; 4 microfarads) before flowing through the voltage dividing lamps (Fig. 11).

The oscillator has generally operated to my satisfaction; and if it ever did not, then one of the little choke coils was to blame, needing a little bending back to the right position, because it had changed its tuning while the set had laid idle for perhaps six months.—*Funk Bastler.*

A Stable Small Transmitter By H. WOLTMANN

(Continued from page 38)

tary condenser and coil were mounted on a stand at the height of the plates of the tubes, which were heated directly from the A.C. network supply lines through a step-down transformer. The tubes were operated with a plate potential of about 700 volts; the plate power varied between 40 and 50 watts, according to the wavelength used. The correct adjustment of the grid bias is important for the power output of the transmitter. For the greatest wavelength, about 40 volts was found most favorable; in the case of the lowest, about 15 volts.

To investigate the suitability of the arrangement for still shorter waves, the rotary condenser was finally eliminated, and the coil was mounted directly to the plate terminals of the tubes. With the two tubes and a wire loop 4 inches long, it was still possible to make the transmitter oscillate. This corresponded to a wavelength of 4 meters, as measured with a Lecher-wire system. It represented the lowest limit of the set.

The output of energy was no longer very great; an ordinary push-pull transmitter, which was operated on the same wave by way of experiment, afforded far better results. The Mesny arrangement permitted reducing the wavelength with the same tubes even further—to about 3 meters. With other tubes, especially "loss-proof" metal tubes, still better results can be obtained with the balanced generator hook-up. On waves of 6 meters and upward, no important difference could be determined in the power output of the two transmitters.—*Funk Bastler.*

NATIONAL PARTS FOR SHORT WAVE USES

In addition to the parts shown below NATIONAL CO., INC., makes a full line of Transmitting Condensers, Parts and Transformers for Every Kind of Broadcast and Short Wave Circuit, Amplifiers and Power Supplies. Write for our catalog sheets—SWC—4/32.

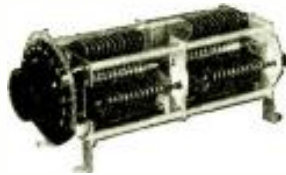

**TYPE TMP
SPLIT STATOR TYPE
TRANSMITTING
CONDENSER**

Especially suited for 60 MC amateur and experimental work on "High C" and push-pull transmitters. Heavy aluminum straight-line capacity plates, with rounded edges and polished all over. Insulation is CROLYTE. Made for 3,000 and 6,000 volts.



**STANDARD
4"
TYPE N
VELVET
VERNIER
DIAL**

Has original and matchless Velvet Vernier mechanism, real vernier scale, reads to 1/10 division. 3 point attachment for easy and accurate mounting. Solid German Silver construction.



**VELVET
VERNIER
DIALS
TYPES B and
BM**

Type B has well known V.V. Variable Ratio of 6-1 to 20-1, bakelite cover; dial is quickly attached without special tools. 5" Diam. New Type BM is 3" diam., for use on small receivers and transmitters. Made with fixed ratio only.



**DRUM TYPE
VELVET-
VERNIER
PROJECTION
DIAL TYPE H**

Has same velvet smoothness of all V.V. Dials. Scale is projected in color on to ground glass screen and reads the same from any position, with enlarged figures and scale divisions. Easy to read—no Parallax.



**SE & ST
VARIABLE
CON-
DENSERS
for SW Use**

A special high-frequency design not a cut-down broadcast job. Has insulated main bearing and constant impedance pigtail. Makes tuning possible on short waves. SE has 270° Straight frequency line plates. ST has 180° Equitune plates. Capacities up to 150 mmf.



**R.F. TRANS-
FORMERS
AND
COIL-FORMS**

Available to cover from 33 MC to 150 KC. Forms are moulded R. 39, new low-loss coil material developed by Radio Frequency Laboratories exclusively for us. Blank forms are also available for winding experimental coils with 4, 5 or 6 prong bases.



**AUDIO
TRANSFORMERS**

National Co. makes audio-transformers for all purposes—for receivers, for transmitters. There is a new line of special NATIONAL Transformers for Class B Push-Pull Modulators, and Public Address Systems.



**NATIONAL N.C. 5
SHORT-WAVE
CONVERTER
MOST POWERFUL MADE**

Easily attached to any set in 10 minutes. Works on any set. Has two extra stages of amplification. No plug-in coils. Has own built-in power supply. R.C.A. Licensed. In standard metal cabinet model, and De Luxe Model with solid inlaid mahogany cabinet, shown above.



**NEW 6"
VERNIER
DIAL TYPE
NW**

Solid German Silver. Has flush vernier, estimates to 1/20 Division. Has 3-point variable ratio. Fully patented construction. For amateur and laboratory uses.



**NATIONAL SW-45
THRILL-BOX**

The outstanding short wave receiver. Range 9-2000 meters. Very high signal to noise ratio. True single control tuning. Made both in low drain Battery model and in humless A.C. model with special power supply. R.C.A. Licensed.



**SHORT WAVE POWER
UNIT — TYPE 5880**

A separate unit for S.W.A.C. power supply. Power transformer has electrostatic shield between windings, R.F. Filter on Rectifier Tube and special filter section, for humless operation. Separate 2.5 Volt Filament Supply. R.C.A. Licensed.



SHORT WAVE MANUAL

64 Pages of latest data on Short-Wave Reception and Receiver Construction by Leading Short-Wave Authorities. Volume 2, now ready, contains ENTIRELY NEW and different material than Volume 1. Price each, Vol. 1 or Vol. 2, 50c. Send today enclosing stamps or coin.



NATIONAL
Precision Radio Products



NATIONAL COMPANY, INC., Sherman, Jackson & Abbott Sts., Malden, Mass.

Heinrich Hertz

By DR. ALBERT NEUBERGER

(Continued from page 10)

mother informs us, very clever with his hands. He readily learned to draw and model. Later he developed all sorts of skill in craftsmanship. He even had instruction in lathe-work. What he learned with the master mechanic Schultz, who always regretted that "little Heinrich" did not stick to this trade, in which he proved so apt, he soon made practical use of. He made physical instruments, the brass screws and all other possible parts of which he himself turned. Very soon he began to consider some of the great problems of science. He began by making a "spectral" apparatus.

Confronted with the choice of a profession, Heinrich Hertz wished to become a *builder*. In 1875 he entered a building concern in Frankfurt-on-the-Main, to prepare for this profession. He helped in the building of the new bridge across the Main. In 1879 he entered the Technical College at Dresden. While serving his year in Berlin with the railway regiment and preparing for the officers' examination, he came into closer contact with the *theory of electricity*. Concerning this field, in which he was later to do such transcending pioneering work, he wrote:

"The theory of electricity is so foreign to me, that I should almost like to chime in with the regular question of the officers: what is really the purpose of the whole nonsense?"

Soon, however, his view changed and with it his whole life. In Munich, where

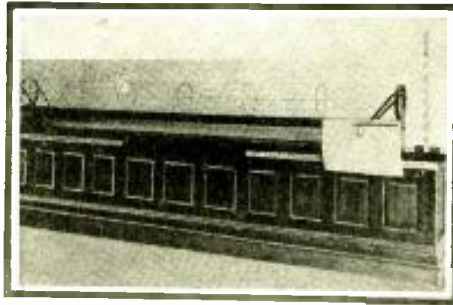

The Hertz apparatus with which he demonstrated the famous "skin-effect".

he intended to pursue his studies at the Technical College, he suddenly resolved to "change horses" and to devote himself

to *mathematics* and *physics*. His father agreed. From Munich he went to Berlin to the famous Professor Helmholtz. Here the university had offered a prize for a dissertation on a subject in the field of—*theoretical physics!* Hertz at once set to work and actually won the prize. He became Helmholtz's assistant and settled in 1883 in Kiel. In 1885 he was called to Karlsruhe as regular professor of experimental physics.

Here is the classic place, where he solved the problem he had set as his goal, in so fortunate a way. When he reported summarily concerning it in 1889 at the assembly of natural scientists in Heidelberg, the scientific world was astounded! All was so clear and evident—so full—and proven in such a decisive way, that there could be no valid objections.

The electrical waves became, from that time on, the object of manifold investigations, always based on the principles laid down by Hertz and always confirming them. In 1889 Hertz accepted a call to the University of Bonn. In August, 1892, there became first evident the indications of an illness against which neither the physicians, the stay at bath resorts, nor the southern sun could help. On the first of January, 1894, Heinrich Hertz died. The mighty scientific work which he left behind will long remain the cornerstone of a structure in which science and technology will be proud to have equal claims.

In Next Issue

A NEW

S-W SUPER-HET

YOU CAN BUILD

Fully illustrated with all coil, resistor and condenser details.

By Clifford E. Denton

PORTABLE RECEIVER



The most compact and efficient receiver available. Capable of Receiving Short Wave Broadcasting and Code Signals from extreme distances. *Ideal for CAMP — PLEASURE CRAFTS — AMATEURS — SHIP OPERATORS — FOREST PATROLS.* LISTEN IN ON THE INTERESTING POLICE DEPT. WORK — WEATHER REPORTS — TIME SIGNALS. APPROXIMATE LIFE OF BATTERIES 1 YEAR.

REL

THREE PLUG IN COILS

Covering continuous wave length range from 20 to 100 meters supplied with this Receiver completely wired and tested, \$30.00 (no tubes or batteries included).

ADDITIONAL SPECIAL COILS, \$1.50 each.
100 to 200...190 to 370...360 to 500 meters.

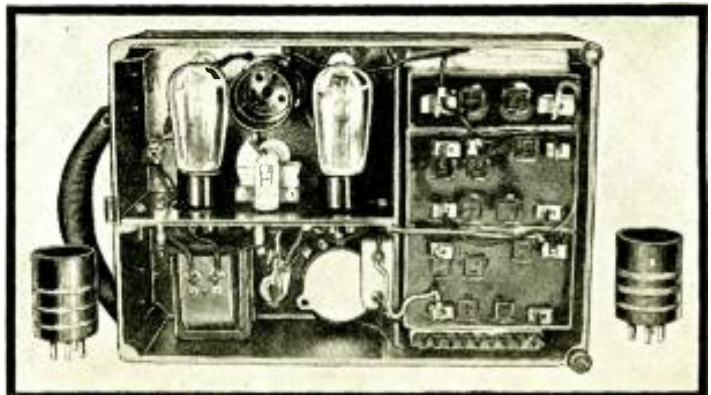

RADIO ENGINEERING LABS., Inc.
2514 - 41st Avenue, Long Island City, N. Y.

An Economical S-W Receiver

By LEWIS EWING, W8ECH

(Continued from page 41)

have worked fine for over a year of more or less constant use.

The 2-megohm grid leak (R1), I took from a one-tube BCL receiver; but the .0001-mf. grid condenser (C6) I bought.

The rest of the A.K. set was torn down, and the condenser cases and coils junked. Then the variable condensers were mounted on a 3/16-inch walnut panel 7 inches by 17 inches. The baseboard is 7 by 17 by 1. (It would be better to use a bakelite or aluminum panel as the condenser shafts are not very long.) The only changes made in rewiring the audio amplifier were to connect a by-pass condenser (C4) between the "B plus" lead on the first transformer and the grounded negative lead, and to shunt a quarter-megohm grid-leak (R2) across the secondary of the same transformer. I am using a 1-mf. condenser, but in some cases none is necessary; and the value is not very critical. The radio-frequency choke (RFC) was wound on a one-inch form and consist of a three-inch winding of No. 26 double cotton wire.

The original sockets are OK for the tubes, but I use a Pilot UX socket for the tube-base coils. The antenna condenser (C5) is a Hammarlund midget of .000032-mf. capacity, and is usually set with the plates about half meshed. I use a type '12 detector; '01-A first audio; and another type '12 second audio with the voltages as marked in the diagram. First I used this set on 14 mc. and it brought DX in fine. Then my "B" batteries wore out and I got a "B" eliminator. It has too much hum for this band, and so I now use it only on 3.5-mc. and 7-mc., where it works fine. I can use it with the speaker on both bands easily at present.

Luxtron Mfg. Company Takes Larger Quarters

To facilitate expansion needed to handle enormously increased business, the Luxtron Devices Company has been incorporated under the name of Luxtron Mfg. Co., Inc. The same executives will continue to direct the destinies of the new corporation. Mr. S. Wein is the president and chief engineer. Mr. L. Miller is vice-president and secretary.

Because of the need for larger quarters, the Luxtron company has moved from 338 Berry Street, Brooklyn, N. Y., to 241 Lafayette Street, New York City. The entire fourth floor is utilized in the new location. Executive offices are at the front of the building, with research laboratory and factory occupying the rest of the floor space.

The Luxtron Mfg. Co., Inc., specializes in the production of "photometrically tested" photo-cells and small relays of every kind. This company also produces the well-known Luxtron Kit containing the Luxtron "ST" cell and "R-1" relay.

The Luxtron Mfg. Co., Inc., has just issued an extremely interesting pamphlet on photo-cells and relays.

The new pamphlet describes how the photo-cell or "electric eye" functions and also how the relay works with the cell. Many different experimental and commercial applications of photo-cells are mentioned. The booklet also describes the new "ST" Luxtron cell, the Luxtron "R-1" relay and the popular Luxtron kit.

Anyone interested in photo-cells may obtain the new Luxtron booklet gratis by writing to the Luxtron Company.

ROYAL SHORT WAVE RECEIVER

SCREEN GRID—POWER PENTODE
WORLD WIDE RECEPTION
GUARANTEED



Royal Model RP
LIST PRICE \$25.00

A NEW Super-Sensitive Short Wave Receiver especially designed for the reception of broadcasting and code from all parts of the world, airplane reports, police transmissions, ship conversations, etc. Guaranteed to give better results than others selling for higher prices.

Sturdily constructed on a heavy metal chassis and enclosed in a neat crackle finished cabinet it presents an attractive, efficient appearance. A full vision dial and a combination regeneration,—volume control (with automatic switch) makes tuning remarkably easy. This set tunes from 14 to 200 meters (550 meter coil 75c extra). A special "Ham" model is available with the amateur bands widely spread. (State your choice.) The use of a UX-232 screen-grid detector and a 233 power pentode amplifier gives extreme sensitivity and tremendous volume.

SPECIAL PRICE

\$14.95

Set of Tubes \$2.20
Batteries \$5.45
EXTRA

In Kit Form \$11.95

OTHER MODEL RECEIVERS

These scientifically designed kits contain the highest grade parts throughout, to obtain maximum results. Every part down to the last nut is included. Complete construction and operating instructions in simple terms included. Easily understood by anyone; will take the guesswork out of home construction. Also supplied AWT (Assembled—Wired—Tested).

All necessary parts of highest quality, including drilled panel and baseboard, and complete instructions. Micro-vernier dial makes close tuning easy. Tunes 11 to 200 meters. (550 Mc'er coil 75c additional.) Also supplied in special "Ham" type with the 20, 40, and 80 meter bands widely spread. State choice when ordering. These models are designed to work with 230 or 201-A type tubes. A pentode or an ordinary output tube may be used.

MODEL R1

A sensitive one-tube receiver with a world-wide range! Special refinements make this set superior to any other.

AWT \$8.95
Kit 5.95

MODEL R2

Same as R1 but with a stage of pentode audio amplification to greatly increase the volume.

AWT \$11.25
Kit 6.75

MODEL R3

Same as R1 but with two stages of quality audio amplification for loud speaker reception.

AWT \$13.20
Kit 8.20
Uses power pentode output for tremendous volume.

(Neat bakelite form plug-in coils used instead of large sloppy coils with wire leads easily broken! Best results!)

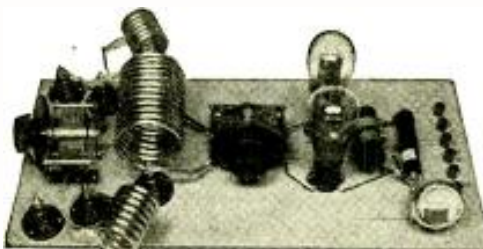

Royal Model TP-1

50c extra. Readrite meter 80c extra. Jewell \$5.00. (Meters not necessary for operation.)

TRANSMITTERS

You can work these transmitters with dry cell tubes with batteries, up through receiver tubes with "B" Eliminators, to a real 210 power tube with one of our high-power transmitting power supplies and obtain amazing results all the way. Heavy copper tubing inductance, good quality variable condensers (add \$1.90 each if you wish Cardwell "condensers"), heavy transmitting grid leak, special choke, large porcelain stand-off insulators, resonance indicator, sockets, condensers, dials, hook-up wire, etc., make these transmitters the finest money can buy! Puts out a strong, steady signal that will carry all over the world. Get "On the Air" NOW with a real outfit and experience a new thrill! Inductance supplied for 40 meter band. All models will work on two bands, but maximum results can be obtained only on the band for which it is designed. 80 meter band

MODEL TS

An extremely simple transmitter to construct and operate. Only one dial to adjust. Uses the well-known Tuned Plate-Tuned Grid Circuit noted for its stability.

AWT \$10.79
Kit 5.75

MODEL TP

A standard TP-TP transmitter with more flexibility than the Model TS. Uses two variable condensers.

AWT \$12.45
Kit 7.50

MODEL TH

Uses the famous Hartley circuit, a favorite with amateurs. Most easily adjusted transmitter.

AWT \$11.75
Kit 6.45

MODEL TP-P

Push-Pull transmitter. Uses two tubes and has double the output. When two 245 tubes are used with 350 volts the output is as great as a single 210 with 600 volts and far steadier. For UX-215 tubes.

AWT \$14.95
Kit 9.45

TRANSMITTING POWER SUPPLIES

These well filtered units will give your transmitter a pure DC note with a "Wallop" behind it! Contains heavy duty power transformer, large choke, high voltage condensers, sockets, cord and plug, etc. Delivers both filament and plate voltages. All operate from 110 volt 60 cycle AC house line.

MODEL PA
Uses one 280 tube. Output is 300 volts DC at 50 MA, 7 1/2 volts at 2 amp. (easily cut to 5 or 2 1/2 V.)
AWT \$8.45 Kit \$4.50

MODEL PB
Uses one 280 tube. Output is 350 volts DC at 100 MA, 2 1/2 V. CT—2A, 2 1/2 V. CT—3A.
AWT \$10.95 Kit \$7.95
(For Model TP-P 245 Transmitter.)

MODEL PD
Uses two 281 tubes. Output is 500 volts DC at 125 MA, 7 1/2 V. VT—2 1/2 A, 2 1/2 V. CT—12A.
AWT \$15.95 Kit \$10.95

MODEL PE
Uses two 281 tubes. Output is 650 volts DC at 170

MA, 7 1/2 V. CT—2 1/2 A.
AWT \$17.95 Kit \$12.95
(For Model TP-P 210 Transmitter)

SHORT WAVE ACCESSORIES

To insure the maximum results from your receiver and transmitter we advise the use of our SPECIAL SHORT-WAVE TUBES. Every one is tested in a short-wave receiver or transmitter. RCA Licensed. Free replacement for 15 days.

UX-201A 40c	Sensitive 2,000 Ohm Headsets \$1.40
UX-199 95c	Baldwin Loud Speaker Units \$1.45
UX-210 \$2.95	Phone Plugs 25c
UX-230, 231, 237 85c	Antenna Kits 95c
UX-232, 233, 235, 236, 238 \$1.10	High Grade Batteries:
UX-215 55c	Dry Cells 35c
UX-217 \$1.20	4 1/2 Volt C 35c
UX-250 \$2.05	2 1/2 Volt C 85c
UX-280 60c	45 Volt Standard B. \$1.40
UX-281 \$2.45	Filament Transformers for AC operation of Transmitters: 2 1/2 Volts at 10 Amps \$2.95
	7 1/2 Volts at 4 Amps 2.95

IMMEDIATE DELIVERY On any Radio Part All of our Short Wave Apparatus is designed by Government licensed short wave operators with a vast experience in this field.

20% DEPOSIT REQUIRED WITH ALL ORDERS—Foreign Orders should contain full remittance plus transportation.

Harrison Radio Company
142 Liberty Street Dept. C-7 New York City

Radio Ghost

By DR. F. WOLF

(Continued from page 22)

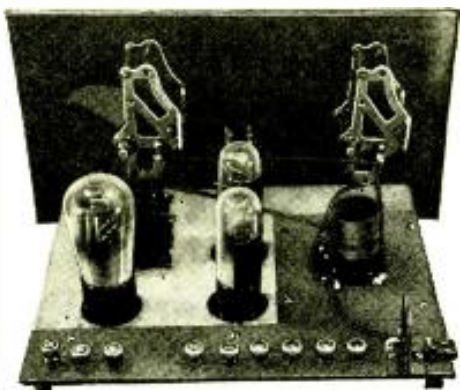

NEW DELFT SHORT WAVE PENTODE SETS AND KITS!!

Use Pentode tubes!! A Pentode tube costs no more but gives the volume of two ordinary tubes! Our sets are specially designed to use these tubes! These sets are BETTER!! Anything that runs on at short waves (also ordinary broadcasts) can be picked up with any of these sets, including foreign countries. Latest factory chassis and all circuit improvements! Get a MODERN set! ONE-TUBE SET COMPLETE (D.C.) \$7.95. Tube, \$1.60 extra. Two dry cells and one 45-volt battery completes it. Can be used as is, as a one-tube separate S. W. set, or as a converter for either an A.C. or D.C. broadcast set. Build a simple oscillator to it, and make it a superb converter of the latest design. KIT of Parts, \$8.45. ONE-TUBE A.C. SET \$9.95. Tube, \$1. A.C. Kit, \$7.45. HIGH GAIN TWO-TUBE SET (A.C. or D.C.), uses screen-grid, also pentode tube, \$13.00 complete. Tubes, \$4.50 extra for D.C. set; \$2.50 extra for A.C. set. D.C. Kit, \$7.95. A.C. Kit, \$9.95. TWO-TUBE KIT (pentode in audio), D.C., \$6.95; A.C., \$8.95. HIGH GAIN THREE-TUBE SET (works speaker, screen-grid and pentode (A.C. or D.C.)), Complete Set, \$18.00. Tubes, \$6.75 extra for D.C. set; \$3.95 for A.C. set. D.C. Kit, \$10.95; A.C. Kit, \$11.95. THREE-TUBE KIT (pentode in audio); D.C. Kit, \$8.95; A.C. Kit, \$10.95. Any A.C. sets or kits need a \$3.45 filament transformer and a cheap B-eliminator or power pack to complete them. A.C. sets can be operated temporarily on B batteries; buy the power pack later. The D.C. two- and three-tube sets need two dry cells and three 45-volt batteries. Batteries are cheap now. Ordinary loudspeakers, B-eliminators, aerial and ground connections can be used. Our prices may LOOK higher but they are really the lowest; we believe in showing you what you really need. All sets are equipped with a complete set of plug-in coils. A full set of instructions also; shows where to put each wire so you don't even need to know hookups to build one of these easily assembled sets. Of course, they are good as any and better than most! Fine headphones, \$1.95 pair. A.C. Tubes, tested at short waves, \$1 each. FOUR-TUBE UNIVERSAL SHORT WAVE AND TELEVISION RECEIVER (Tuned screen-grid input R.F. stage, regenerative detector, audio and pentode tubes—works like a 5-tube set!); D.C. Kit, \$17.95; A.C. Kit, \$19.95. Assembly charge on 4-tube sets, \$10.00. Looks like photo but has shielded stage to right. A WAVEMETER will locate that desired station on the dial of your set!! Nothing else necessary to use it with your set. Tunes from 14 to 250 meters. Accurate. Shielded. Works with any S. W. regenerative (A.C. or D.C.) receiver. (We have a special wavemeter for superheterodynes and S. H. converters. Ask for leaflet.) Complete Wavemeter with 3 coils, accurate chart, and Full Instructions — your price, \$8.95 (List Price, \$15.) Ham-Band Wavemeter. Looks like above meter. Extreme accuracy. With calibrated coil for any one Ham Band, \$6.95. For each extra band, add \$2.



TWO-TUBE PORTABLE SET!!

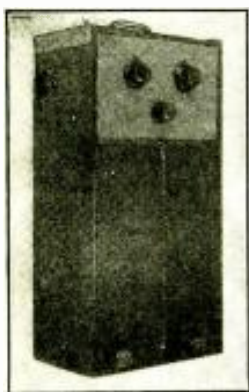

Here's your Set!! Takes up minimum space, easy to move around. All complete as shown. Gives fine loud headset volume on any short wave. Will also get ordinary broadcasts! Light in weight, 1,000 miles on small aerial. Extra slip inside case. Uses 2-volt tubes and PENTODE TUBE (works like 3-tube set!). Size: 9" x 18" x 7" deep. Complete Kit, including case and tubes, \$18.00. Completely assembled set, with tubes, \$25.00.

By all means get our low-price catalogue before you buy anything in the short-wave line!! Send few stamps for same. How about ultra-short waves? DEVOTED ENTIRELY TO SHORT WAVES!! See past issues of this magazine for descriptive

writups of our complete lines. Send a few stamps for our wholesale catalogue of receivers and kits, transmitters and kits, coils and coil-winding sets, wavemeters, radio-frequency amplifiers and kits, code practice sets, and complete lines of inexpensive sets, parts and set-building instructions. 2% off for cash in full. If C.O.D., send about 15% deposit in \$1 bills or stamps, pay rest to postman when delivered.

Manufactured by

DELFT RADIO CO.

524-B Fairbanks Ave. Oakland, Calif.

tubes. The irregularity with which the emission from the sun takes place is reflected in the irregularity of the occurrence of the Northern Lights and in the constant quivering and flickering of the phenomenon itself.

It is of the greatest importance that the earth represents a large magnetized sphere. Accordingly the particles coming from the sun cannot plunge directly at the earth in irregular fashion, but are diverged by the magnetic field on to very definite, peculiarly curved orbits. Störmer has made a mathematical investigation of these orbital possibilities. Birkeland, and most recently Brüche, have imitated in the laboratory on a small scale, the conditions existing between the earth and the sun; in spaces almost void of air, they shot streams of electrons from suitable sources of electrons, against a small magnetized sphere, the "artificial earth".

The processes of the polar lights could thus be reproduced in a wonderfully beautiful manner. It was apparent that all the particles are deflected in great arcs toward both poles of the earth, and can enter the atmosphere and excite the polar (auroral) lights only in their vicinity; while a large space about the earth has to remain free from them. The shape of this empty space resembles that of a torus or bolster; more clearly, it is similar to that of a "gigantic apple". The earth itself must be thought of as a small sphere at its central point, and so aligned that its magnetic axis coincides with the axis of the apple indicated by the stem. In the entire space within this apple-shaped protuberance, the electric particles of the sun cannot enter because of the earth's magnetic field. Photographs which Birkeland has made of his laboratory experiments, show this torus-shaped space, free from charges, in the vicinity of his model earth. Fig. 1, which is taken from a publication by Störmer, gives an idea of these conditions.

How Interstellar Space Echoes Can Occur

From within toward the earth, that is, as viewed from our position, this dividing surface forms a sort of huge concave mirror. If radio waves which go out into space from the earth fall upon this, then, much as with the "fading effect" on the ionized Heaviside layer, they are reflected by the clouds of electrons speeding along the surface of the torus, and in consequence of the concave form of the surface are even collected and cast back to earth (see Fig. 2). In this way there actually occurs a perceptible "echo", although the distances traversed by the waves are enormously large.

Especially valuable conclusions are given by the various durations of time observed between the "actual signals" and their "echoes". For they, of course, indicate paths of various lengths for the waves, which always go equally fast, accordingly entirely different distances of the reflecting surfaces from the earth. Calculation shows that the size of the torus-shaped space on whose limits the waves are reflected depends on the velocity of the electrons coming from the sun (see Fig. 3). Rapid particles can penetrate deeper into the magnetic field of the earth than slow ones, before being deflected to the poles. Therefore from

the intermediate time observed in the case of the echo, one can directly calculate the velocity of the arriving particles, and in the fact that such tremendously different time periods were observed we have the proof that the sun sends out in alternation particles of entirely different velocity, beginning with the ordinary cathode rays of a vacuum tube, and ranging to the fastest beta-rays of radioactive decomposition with almost the velocity of light.

Relation of Earth's Magnetic Axis

Störmer's considerations showed, furthermore, that for simple geometrical reasons, such a wave reflection can only be effective if the direction from the earth to the sun is approximately perpendicular to the magnetic axis of the earth. But since this varies but little from the axis of rotation of the earth, the necessary adjustment never occurs during the entire winter.

Actually, in the last few winters, in spite of continual observations, "echoes" have never been observed; on the contrary, the first signal from space was heard exactly at that point of time in the spring for which Störmer had prophesied its recurrence—actually a good proof of the correctness of his excellent explanation.

Pedersen, likewise, goes further in his theoretical treatment than Störmer. In the case of the irregularity of the solar emission, it is clear that the above mentioned torus surface is not always perfectly (tightly) surrounded by electron clouds; on the contrary, quite frequently the radio waves can speed out untroubled into space through great gaps. Then it is conceivable that even further out, they occasionally strike other clouds of electrons, which are not headed straight for the earth but elsewhere in space. This is especially to be expected in the vicinity of the sun itself, where the density of these swarms must be great.

Occasionally, however, suitable reflections might occur, which would return the radio waves back to earth, collected together, even after travelling such tremendous distances. Fig. 4 shows such a possibility. The waves would need about 17 minutes to reach the sun itself and get back to us. People have listened for such extremely "belated echoes," and as a matter of fact the engineer, Hals, in Bygdö, observed "echoes" which arrived more than 3 minutes after the real signals; even as much as 4 minutes and 20 seconds later!—*Die Umschau*.

More About the
SHORT WAVE
LEAGUE

In Our Next Issue!

Don't Miss It!

Delft Radio Issues New Catalogue

The Delft Radio Co. has received so many requests for the hook-ups used in its modern short-wave sets, that the hook-up shown in Fig. 1 was sent in for the benefit of our readers. Although this circuit is designed especially for a two-tube set, using the 2-volt dry-cell tubes, now so popular, slight modifications will adapt it for A.C. operation. Complete Delft kits of parts are available for building A.C. or D.C. sets of this type. The full instructions furnished make it easy to assemble the sets, even for those without a working knowledge of radio hook-ups. A pentode tube in the last stage gives exceptional volume for two tubes—often too loud for headphones.

Besides manufacturing a complete line of short-wave receivers and kits, and a special wavemeter for locating stations on the dials of short-wave sets, Delft

Radio also manufactures transmitting sets and kits, coils, coil-winding sets, radio-frequency "booster" units for increasing the volume 100 per cent from existing sets, code-practice sets and a complete line of parts. The company devotes its entire plant to short waves and ultra-short waves. A few stamps bring the firm's illustrated catalogue of the latest edition, covering many interesting short-wave lines.

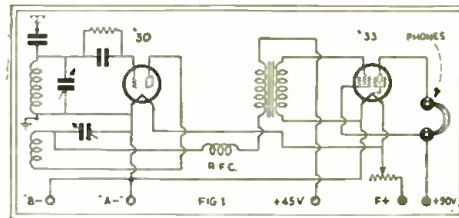

Columbia "Gem" S-W Receiver

A NEW practical short wave receiver that combines features never before found in this type of set is now being placed on the market.

It uses three screen-grid tubes of the new two-volt type, making for economical operation. Enormous amplification is obtained by the use of the last screen-grid tube as a space-charge audio amplifier, a feature entirely new in short wave work. The first screen tube is an R.F. amplifier specially designed to eliminate all antenna dead-spots, making for easy tuning. The second screen-grid tube is a non-radiating detector specially designed for maximum sensitivity.

Four plug-in coils are supplied to cover all wavelengths from 15 to 200 meters. The broadcast band can be covered by an additional coil.

The speaker jack has a switch attachment which automatically disconnects the "B" batteries from the set, thus preventing them from being drained when the set is not in operation. The three tubes have a total drain of only 180 milliamperes on the "A" battery and a very small consumption on the "B" battery. An exceptionally smooth acting control is used for regeneration and volume.

One of the features of the set is the fact that all batteries are contained en-

tirely within the receiver proper; compartments being provided for this purpose. The manufacturers have designed the set in this manner with the intention of eliminating messy outside wires which are so characteristic of the average short wave set. This also reduces the space necessary for the operation of the receiver to a minimum.

It is housed in an attractive japanned black metal cabinet and is equipped with a micro-vernier full vision dial for easy and accurate tuning. The metal cabinet, acting as an electro-magnetic and an electro-static shield, eliminates all undesirable hand-capacity effects so prevalent in unshielded sets.

Stations all over the world have been logged on the loud speaker with remarkable ease.

The price itself is a feature, being placed so low that the set is within the reach of any short wave fan.

For those desiring a smaller receiver, the manufacturers offer their one tube screen-grid model, which, like the larger set, has all the batteries self-contained within its metal cabinet. It enjoys the same distinguishing features as the larger model.

These sets are manufactured by the Columbia Specialty Co., of New York, N. Y.

New Roland Receiver By JACOB P. LIEBERMAN*

WITH a simple circuit, comprising only a detector and a stage of audio, virtually the entire world has been covered, and as many as 87 stations tuned in during one night on the new Roland set. This is no surprise, since the circuit is about 10 years old, and not only has stood the test of time, but has come in for a little improvement because of new tubes.

The tubes are two '30's, and as these operate at 2 volts on the filament, and draw only 60 ma each in the filament circuit and a total of about 9 ma in the plate circuit, the battery drain is relatively small. Besides, the new tube—if it still can be called new—is a good one for short waves, which applies to the detector. for, of course, the audio tube handles only audio frequencies. The cir-

cuit is for earphone operation, or may be fed to an audio amplifier by those who know the simple methods of doing this. The present purpose, however, is to confine ourselves to the circuit as printed—earphone reception, but earphone reception with a vengeance.

The only trouble that has been experienced has to do with the smallest coil. In any such short-wave outfit the smallest coil will bear investigation, as results depend absolutely on regeneration, and it must be obtained. The way the set is wired has something to do with it.

The rheostat should not be used as a volume control. The feedback condenser will serve that purpose suitably. The only reason for the rheostat is to take up the difference in effective voltages due to battery change with A battery condition (two 1.5 volt No. 6 dry cells in series).

TO MEN WITH AMBITION!



who want to get ahead in radio

THIS ad is written to you! If you have a spark of ambition, it may be the answer to your search for advancement.

Radio, as everyone knows, has developed far beyond the point most men believed possible. Its future may be even greater. So it's wise for you to get into radio now, thus be ready to cash in on the future!

RCA Institutes offers you the radio knowledge you need . . . either through resident schools in New York, Boston, Philadelphia and Chicago or extension courses for home study. At this, America's oldest, largest radio school, established for nearly a quarter century, you have modern equipment, expert teachers, wide variety of courses, association with radio's largest research laboratory. Yet tuition costs are moderate.

Get into radio! Learn its how and why and what. Thus be ready to tie up to radio's future. Check the branch of radio you like best—and mail the coupon now, before you forget.

A Radio Corporation of America Subsidiary



RCA INSTITUTES, INC.

Dept. CS5 75 Varick St., N. Y.

Please send me your General Catalog.

I am checking below the phase of radio in which I am interested.

- | | |
|--|---|
| <input type="checkbox"/> Microphone Technique | <input type="checkbox"/> Talking Pictures |
| <input type="checkbox"/> Broadcast Station or Studio | <input type="checkbox"/> Servicing Home Entertainment Equipment |
| <input type="checkbox"/> Aviation Radio | <input type="checkbox"/> Television |
| <input type="checkbox"/> Radio Operating | |

Name.....
Address.....
Occupation..... Age.....



AMATEURS!

All your radio tube requirements can be supplied by

X-866, \$5.00

S. S. KRESGE
Green Front Stores

Here you will find all types of VAN DYKE Radio Tubes—R.C.A. licensed—double tested at the factory and guaranteed to satisfy you.

VAN DYKE Radio Tubes can be purchased only in S. S. Kresge Stores.

Technical data bulletins available in all these stores or will be forwarded upon request.

VAN DYKE
LABORATORIES
5 Central Ave., E.
NEWARK N. J.



X-841, \$6.75

* Roland Radio Company.

NOW
THE WONDER OF
MODERN SCIENCE

NEVER SOLD FOR
 LESS THAN \$50.00

COMPLETE KIT for \$10.00

There are hundreds of interesting electrical devices that you can make with a photo electric unit. It will turn on the parking lights of your car when the sun goes down or light the lamps in your house at dusk. It will open your garage door when the beam from the headlight is flashed against it—it will detect smoke in your home or protect your safe—there is no end of jobs that a photo cell unit can do in your home.

- PICTURES THAT TALK
- GARAGE DOORS THAT OPEN AT A LIGHT FLASH
- MECHANICAL MEN
- BURGLAR ALARMS, ETC.

all owe their origin to photo electric cells. It is now possible for you to buy a complete photo cell unit in a kit, ready to assemble, including an extremely sensitive photo electric cell, all necessary tubes, wire, resistances, relay, etc., with complete diagrams and an instruction book showing you how to assemble it in an hour—all for \$10.00.

We also furnish you with a book giving complete wiring diagrams and instructions on how to build a number of amazing devices and showing you many uses for your photo electric cell unit. The actual value of this complete kit is over \$50.00—we are making a special introductory price of \$10.00 to popularize experimental work with photo electric cells.

Clip check or money order to the coupon below and mail it today!



HERMAN A. DE VRY Inc.
 53 E. Wacker Drive
 Chicago, Illinois

CLIP THE COUPON BELOW... MAIL TODAY

Herman A. DeVry, Inc.
 53 E. Wacker Drive, Chicago, Illinois
 Enclosed is \$10.00. Please send me the complete Photo Electric Cell Kit advertised in Radio News.

Name.....
 Address.....
 Town.....State.....

A New Compact S-W Receiver

By M. B. SLEEPER

(Continued from page 37)

remarkable records for extreme DX. Even inexperienced B. C. L.'s, who threw up their hands in despair over converter combinations, and declared they couldn't get a thing, are able to bring in no end of stations on the *Dragon*.

There is less background noise with this single super-heterodyne circuit. This takes out much of the distortion, and helps to clear up weak signals. The over-all efficiency is much higher than can be obtained with a converter, too.

Much of the poor reception from converters is due to lack of correct electrical balance between the converter and the broadcast receiver.

No losses of this sort are present in this new receiver, because no converter is interposed between the antenna and the first detector.

Broadcast reception on the *Dragon* shows splendid performance in each of the many parts of the country where the first models were sent for field tests. In Massachusetts, it brings in the West Coast regularly. In New York City it cuts through interference with definite precision.

On short waves, we find the *Dragon* less affected by local conditions, as far as receiving range is concerned, than when a converter is used. In fact, an antenna that is good for broadcasting is generally good for short waves.

Dragon Has New A.F. Circuit

Unusual amplification and quality are obtained by important improvements in the *Dragon* audio circuit. You will notice that a volume control is provided, but no tone control. The reason is that the tone-value and timbre achieved by the A.F. system in combination with the acoustic design of the cabinet, do not require a tone control device. The only result of upsetting this balance is to introduce distortion.

While it is still too early to be certain, it seems as if tone controls may be found unnecessary on all sets where a correct relation of audio amplification to cabinet design is obtained. Certainly the most pleasing reception is a perfect reproduction of the original speech or music.

New Conditions Call for New Sets

The definite demand of the B. C. L.'s for short-wave as well as broadcast reception from a single set has already made the 200 to 550-meter receiver obsolete! This is confirmed by the many different 1932 models of broadcast receivers with built-in converters.

We believe that the purposes of efficiency and economy are best served by using individual sets of coils for the different frequency bands, cut directly into a superheterodyne circuit designed for this purpose.

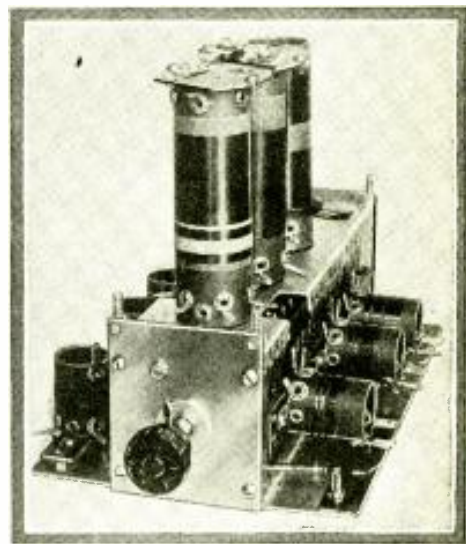

Above: Appearance of the new "Dragon" catacomb, containing the 9 coils used for tuning in all bands from 18 to 555 meters. Switch control knob is seen at front of base.

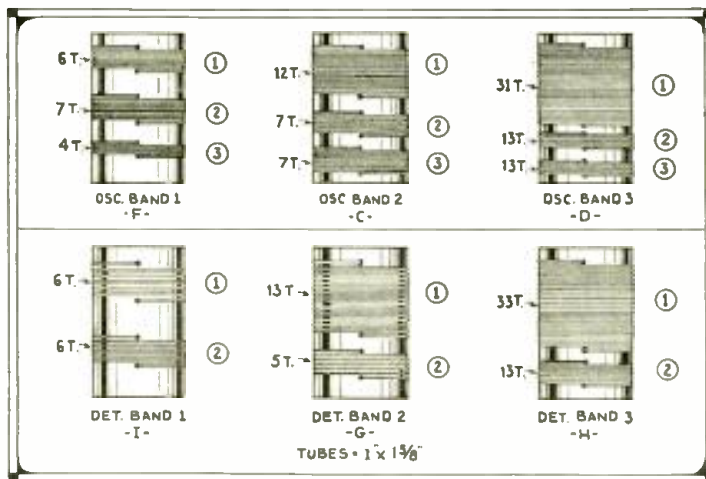

Left: Details of oscillator and detector band coils.

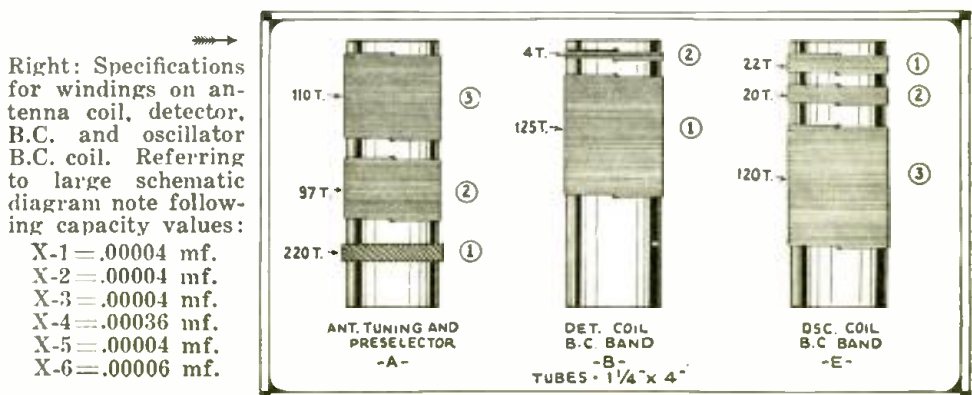

Right: Specifications for windings on antenna coil, detector, B.C. and oscillator B.C. coil. Referring to large schematic diagram note following capacity values:

- X-1 = .00004 mf.
- X-2 = .00004 mf.
- X-3 = .00004 mf.
- X-4 = .00036 mf.
- X-5 = .00004 mf.
- X-6 = .00006 mf.

\$500.00 Short Wave Builder's Contest

(Continued from page 11)

Remember, it isn't only writing an article and getting your name into print and winning a prize.

Big Publicity for You

No, we have something else "up our sleeves" for you! This is going to be a "real" contest, that will be widely publicized. The prize winning sets will be published in a number of national publications, as well as newspapers, which have already made arrangements with SHORT WAVE CRAFT. So the prize winners will not only get real hard cash, but also publicity, which, in time to come, may mean something to them. Manufacturers are always looking for the man with a "new" idea.

It may be superfluous to mention that the judges are naturally going to try out the sets, and it is quite self-evident that the sets *must work and work well!* For that reason, it would be a good idea to test out your set in different localities, after you have finished it, and if the set is an adapter or converter, it should be tried on several different sets and in different localities, because you no doubt know that short wave sets are sometimes "tricky". The builder should make allowances for this and try to have the set as *universal* as it is humanly possible to do. Of course, we are not asking the impossible and trying to change nature, and for that reason the judges will naturally try out the entries, not just in one single locality, but in at least six localities, to be sure that their findings will be fair.

As to *aerials* and *grounds*, these can be included with the set if the builder so desires. If not, binding-posts marked *aerial* and *ground* can be provided at the builder's option. The builder may furnish phones or loudspeakers, batteries, etc., also at his option, if he wishes to make his entry complete, but no set will be disqualified or judged low in merit points, simply because it does not include phones or loud-speaker or batteries.

Please Read Carefully

As to the contest itself, bear in mind that the judges will select those five models monthly which they consider best from the standpoint of *SIMPLICITY, compactness, ingenuity, novelty or circuit used, portability, workmanship!*

Inasmuch as *workmanship* is one of the important factors upon which the judges will base their opinion, do not ruin your chances of winning a first prize by sending in a sloppy, half-finished job. It may take you a few hours longer to turn out a finished piece of work that will do you justice, so don't enter a set that may otherwise be perfect, but which is ruined by poor workmanship. It may indeed spell the difference between the *first* prize and the *fifth* prize.

Of course, you will have to exercise some "inventive ability". This may be expressed in the circuit or in the parts used, or some other novelty that you will have to think up.

A word as to phones or loudspeakers: It is up to you to use either phones or loudspeakers and no restrictions are put in your path if you wish to use either. This is left up to you entirely. No restrictions are placed in your way when it comes to shape or size of the container (cabinet), as long as it is substantial enough and is not "flimsy". Also remember, that you should not wait too long to enter your set in this contest, because waiting too long may bring in other and better models than yours.

Also remember, that the "first prize" announcement will be made in the August issue of SHORT WAVE CRAFT, out July 15th.

Get Your Entry in Early

And please, please, read the rules carefully, and NEVER send your set unless packed carefully in excelsior in a strong wooden box. Fine sets have often been totally ruined because they were packed carelessly. And again—send your set "prepaid"—not CHARGES COLLECT!

A NEW THRILL AWAITS YOU ON

RECEIVER—3-Tube Super-Regenerative Pentode. Covers from 2 to 12 meters. Plug-in coils. Loud speaker operation. (See last issue of "Short Wave Craft" for description.) All aluminum chassis. Full vision dial. New 6-volt tubes—Pentode output. Automatic filament control. Complete. 3-Page Booklet on building set FREE.

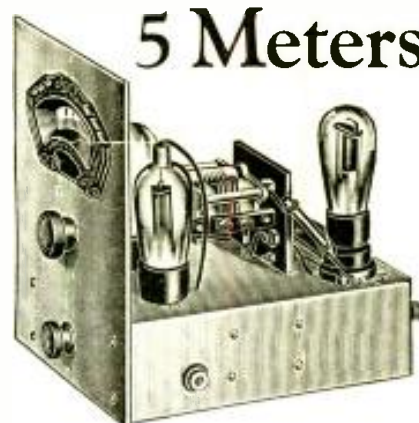

5 Meters

In Kit Form \$14.50

All wired and tested. For D.C. operation
Uses two 237, one 238. \$20.00
For A.C. operation. Uses two 227, one
247. \$20.00

Transmitter — Push-Pull Operation — Phone or Code Uses Any Standard Tubes — Described This Issue

50 mmfd. Midget.55	Any size Grid Leak20
Cardwell Split		7x12 Mounting Base50
Stator	3.30	5 Fahnestock Clips.10
30 mmfd. Grid Adjuster25	2 small Panels20
Antenna Coil.15	5 Porcelain Insulators40
Main Tuning Coils.40	2 Sockets30
R. F. C.15	Miscellaneous50
75-ohm CT Resistor15	Booklet15

**COMPLETE
KIT, only
\$6.75**

Wavemeter \$1.50

Parts may be bought separately. All parts as described. No substitutes.

Total. \$7.35

POLICE SHORT WAVE THRILL BOX

See This Issue of SHORT WAVE CRAFT for Description

1 Eby Ant. & Gnd. Post.15	1 Wood Box, 4x5 1/2 x 645
1 Amrad Variometer65	1 Grip Cap05
1 .00005 Condensers25	1 5-prong Plug with Cable.45
1 Hammarlund MCD140M 140 mmf. Dual Midget.	2.96	1 Coil as specified.20
1 Dubilier .01 Condenser.25	1 piece Bakelite Tubing, 1" x 2 1/2"15
1 2,000-ohm Resistor20	1 Small Spool No. 31 S.C.C. Wire.14
1 Pilot Tube Socket.15	1 KK Vernier Dial60
1 30 mmf. Neutralizing Condenser25		

Total. \$6.90

Your Price for Complete Kit. \$6.50

12,500 MILES ON TWO TUBES

Set Described in Nov.-Dec. Issue of SHORT WAVE CRAFT
KIT FOR THIS REMARKABLE RECEIVER. \$4.50 COMPLETE
Set Complete, Wired and Tested, \$9.00
Above uses two UX230 tubes, 75c each

Same as above but with Pentode Tube for Loud Speaker Operation, with Vernier Dial, Aluminum Panel, etc. — KIT \$12.00
Above, all Wired and Tested, \$16.00

WE SPECIALIZE IN OBTAINING COMPLETE KITS FOR TRANSMITTERS AND RECEIVERS
SEND FOR NEW 64-PAGE CATALOG — A DIFFERENT CATALOG

Terms: Cash or C.O.D., no deposit required. All prices F.O.B. Irvington, N. J.

Short Wave Headquarters. Visit Our Store When in Town

UNITED RADIOBUILDERS
1234-36 • SPRINGFIELD AVE.
• IRVINGTON NEW JERSEY •

**KING - OF - THE - AIR
SHORT WAVE SET**

**POLICE CALLS — AMATEURS
TELEVISION
AIRPLANE CONVERSATION
FOREIGN PROGRAMS**



A SHORT-WAVE receiver, using two 230 (2-volt) tubes, requiring 3 volts filament battery source and 90 volts of B battery. The circuit is detector and one transformer coupled audio stage. This "detector and one step" has been standard for ten years. With this circuit reception the world over has been enjoyed and the elated users number into the teeming thousands. Ranges 15 to 200 meters, using five plug-in coils. Old-timers know this circuit well. Persons who have had no experience with short-waves will find this a most appropriate circuit for a thrilling beginning. The circuit can be wired in 1½ hours.

PARTS REQUIRED: 5 plug-in coils, \$1.50; Hammarlund 0.00014 mfd. tuning cond., \$1.20; Hammarlund 0.0002 tuning cond., \$1.35; three UX sockets, 30c; audio trans., 70c; 50,000 ohm leak, 10c; 300 turn honeycomb, 30c; 0.00025 mfd. Clips, 15c; 200 ohm rheostat, 40c; 20-100 mmfd. equalizer, 20c; battery switch, 20c; 6 bind. posts, 30c; bind. post strip, 10c; vernier dial, 50c; two knobs, 10c; 7 x 10 bakelite panel, \$1.25; 7 x 10 baseboard, 25c.

Complete parts, with blueprint, less tubes (Cat. SW-DAF), @ \$8.95
Two 230 tubes @ total of \$1.92

Roland Radio Company
27-35 Hooper Street
BROOKLYN, N. Y.
Phone: Williamsburg 5-0043-14

Aluminum Box Shields

Beautiful Silver Dip Finish

- 5 x 5 x 5 Knocked-down Coil Shield (like pictured on right)\$1.00
- 5 x 9 x 6..... 1.87
- 6 x 10 x 7 Monitor Size... 3.25



- Bent (Undrilled) "Stand-By" Chassis.....\$.75
- BEST Converter Cabinet..... 3.45
- Coil Cover "Cap"..... .35
- We make any size to order. Alcoa Shield Plate .25

"Buddy" Test Prods

Always sharp pointed, using phonograph needles, 4 ft. wires, spade or phone tips. Colored nipples identify each lead.

75c each. \$1.50 per pair.
WE SPECIALIZE IN RADIO PARTS EXCLUSIVELY—parts furnished for any kit in any magazine.

- K.K. 3" Dial.....\$.59
- Dubilier .01 Cond..... .29
- 2½" x ¾" I. D. Tubing..... .15
- .00005 Fixed Cond..... .15
- BEST Converter Coil Assembly.....Lowest Price
- Sponge Rubber Phone Cushions.....50c pair

Please include sufficient postage

BLAN, The RADIO MAN, Inc.
Dept. SWC 142
89 CORTLANDT ST. NEW YORK, N. Y.

Announcing the Short Wave League

By H. GERNSBACK

(Continued from page 19)

Rule 2.—That I will at all times use my radio equipment for lawful purposes, and particularly to assist in apprehending criminals to the fullest extent of my capabilities.

Rule 3.—That I will, to the best of my ability, help to spread the gospel of short waves wherever possible, be it by word of mouth, by mail, or by personal solicitation, whenever the occasion arises.

Rule 4.—That I will promptly answer all correspondence addressed to me by the LEAGUE or LEAGUE members.

Rule 5.—That I will be governed by the rules and regulations of the SHORT WAVE LEAGUE, and will help in promoting the principles for which the SHORT WAVE LEAGUE stands, so far as shall be in my power, as long as I remain a member in the LEAGUE.

Rule 6.—I agree to return membership badge if for any reason my membership is discontinued.

A membership blank is printed in these pages and can be filled out by the applicant.

If you do not care to cut up the magazine, the LEAGUE shall be glad to send you a printed card upon receipt of a 2c stamp to cover necessary mailing charges.

No blank is valid, nor can it be accepted, unless it is filled out properly as designated. All spaces must be filled. Upon receipt of the application blank, the official badge or button described elsewhere will be mailed. No badge can be mailed unless the applicant first fills out his blank properly.

Clubs and Associations

As mentioned before, it is desired immediately that members start to organize local chapters of the SHORT WAVE LEAGUE. The name of the club or chapter should always be such that the name of the city or locality precedes the words SHORT WAVE LEAGUE. New organizations, such as the Smithville League, should be officially termed the SMITHVILLE SHORT WAVE LEAGUE. If, in some cases, it is not desired to use the name of the locality, because it might interfere with a similar name, another name for the city may be substituted: for instance, the SOUTHWEST SHORT WAVE LEAGUE, or the MISSISSIPPI SHORT WAVE LEAGUE, which, in itself, will serve to locate the local chapter, although, of course, it will not do so as completely as if the name of the locality were incorporated in the new local chapter.

All local chapters, associates, radio clubs, etc., in order to be officially recognized by the SHORT WAVE LEAGUE, must have at least six members. There should be a President, a Treasurer and a Secretary. The address where such a body meets should be stated. Clubs and associations should meet at least once a month. These requirements are necessary to secure publication in SHORT WAVE CRAFT, as well as in the SHORT WAVE LEAGUE OFFICIAL YEAR-BOOK. In this book, to be issued once a year, will be found all the important LEAGUE news, a full listing of all clubs and associations and a complete list of all members.

The LEAGUE particularly endorses and encourages the rendering of scientific lectures on short waves by their members. The members should encourage the

writing of scientific papers, and a copy of this paper should be sent to the LEAGUE Headquarters for publication in the LEAGUE'S Year-Book. The President of the club should select the best paper in his opinion and send it to the editors of SHORT WAVE CRAFT. Providing it has sufficient merit it will be published in due course in either SHORT WAVE CRAFT or the Year-Book, depending upon the value of the paper.

All papers should show the name of the author as well as giving the name of the chapter or club to which he belongs.

Official League Insignia

AN official badge or button, securable only by SHORT WAVE LEAGUE members, is illustrated here. It has been designed especially for the LEAGUE members. It is a distinctive as well as a striking design, and measures three-quarters of an inch in diameter. It is inlaid in real hard enamel in three colors—red, white and blue.

The button is heavily gold-filled, and is guaranteed by the makers not to tarnish for two years. They claim that it will not turn "brassy". You will be proud to wear one of these distinctive badges. It will serve as a means to bring together members who otherwise might not know each other. The SHORT WAVE LEAGUE furnishes the button at cost, the price, including mailing, being 35c. A solid gold button is furnished for \$2.00, prepaid, to those who desire to have a better button.

All communications should be addressed to SHORT WAVE LEAGUE, 96-98 Park Place, New York.

CORRECTION

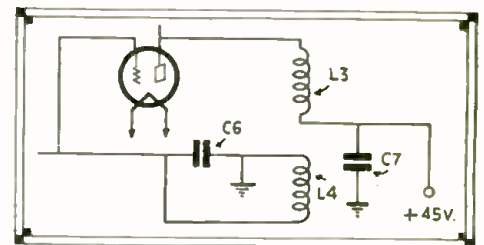

Hook-up above shows proper connection of coil L4 in 4 to 7 meter super-regenerative receiver shown on page 409 of April issue.

How "Te-Ka-De" .4 Inch Wave Bridged 2/3 Mile

By DR. F. NOACK

(Continued from page 24)

and polarization, can be performed very beautifully.

The wavelength can easily be measured by moving the receiver's mirror in the direction of the optical axis. Then at distances of half a wavelength, one gets alternative maxima and minima of sound volume. By measuring the distance between two sound maxima or minima, it is an easy matter to determine the wavelength itself exactly.

More About the "Midwest" Converter

(Continued from page 23)

converter is tuned in to the oscillator sharply and, with volume control on "full," the variable audio oscillator is slowly rotated from 50 cycles to 2000 cycles. If any suspicious points on the oscillator dial are noted, the vicinity of these points are searched with the audio oscillator until resonance is produced and the howl results. These points are usually very sharp and easily cured by loosening or tightening a screw in the loud speaker mounting. These points that are so difficult to find are not likely to occur in the customer's home. The ones that trouble him are those that occur on unmodulated signals and these are very easy to find. The other sharper type caused accentuation of certain notes when they occur on the wood-winds, 'cello, etc.

A Police S-W "Thrill-Box"

By HUGO GERNSBACK and C. E. DENTON

(Continued from page 16)

for best results in such sets. As a rule, only about six tube sets work with loud-speaker intensity in connection with this adapter. The more tubes in your broadcast set, the better the results.

List of Parts

- 1—Antenna post.
- 2—Ground post.
- 3—Anrad vernier varometer No. 2610.
- 4—Aerovox .00005-mf. mica condenser.
- 5, 10—Hammarlund 140-mmf. midget dual condenser, MCD, 140M.
- 6—Dubbler .01-mf. mica shielded condenser.
- 7—2,000-ohm 1 watt carbon resistor.
- 8—Pilot tube socket.
- 9—30-mmf. neutralizing condenser.

Miscellaneous:

- 1—Wood box 4"x5 1/2"x6" (card file case).
- 1—Sure-grip screw grid clip.
- 1—5 prong plug with cable.
- 1—Coil (see sketch for turns and wire size).
- 1—Piece of bakelite tubing—1"x2 1/2".
- 1—Small spool No. 31 single silk wire.
- 1—Vernier dia.—K-K. or National midget.

Dead Spots—Their Cause and Cure

By EDGAR MESSING

(Continued from page 39)

to a lower frequency. But at this frequency the short-circuiting effect will be lessened, because the reactance of condenser C1 will be increased. The dead-spot may thus be effectively eliminated.

Band two's dead-spot was investigated in the same manner and the No. 3 grid coil was found responsible and for the same reason—coupling through the switch. The same solution cannot be used here, obviously, because the introduction of resistance at "y" would render the tuned circuit useless.

A compromise was effected—since the dead-spot couldn't be removed it had to be made harmless. In its present position it was in the middle of an important relay band. A small condenser was connected across the coil so that the spot was moved to an unimportant frequency.

The two illustrations above cover the majority of *regenerative detector* dead-spots.

Three Absorption Cases

Three other absorption cases might be mentioned: R.F. choke effects, inductive resistors, and antenna effects. Figure 4 illustrates the first two cases. If R, a wire-wound resistor and C resonate anywhere in the range covered, no signal or only a very weak one will be heard at that point. If the R.F.C. is series-resonant at some frequency then it will "short" the output of the tube at that frequency and no signal will be passed on.

Experienced constructors usually make it a point when they run up against dead-spots to examine each R.F. choke very carefully. Luckily, now there are good chokes available but there was a time when the radio store choke would do more harm than good.

Antenna dead-spots, while differing from the ones already considered are of the same type. A set's first tuned circuit is usually coupled to the antenna by a small condenser or coil. The constants of the antenna circuit may be such that at some frequency the antenna may act like a short-circuit across the coupling unit, with resultant ruination of the tuned circuit. Looser coupling, antenna loading or an antenna adjustment of some sort are the possible remedies.

The illustrations above cover practically 95 per cent of the dead-spot cases the average constructor will meet. Short wave converters and superhet builders may, however, meet with the interesting cancellation type of dead-spots. Figure 5 will help the explanation.

Cancellation Type Dead-Spots

V1 is the oscillator which induces a voltage in the detector V2 by *magnetic coupling*. During the design of a converter now on the market, whose circuit was almost identical with Fig. 5, two signal dead-spots were found. The usual procedure was followed to locate their cause but with no result. Close examination revealed that while the oscillator was operating smoothly at the dead-spots, there was no voltage on the detector grid. In other words the oscillator was inducing a voltage in the detector grid circuit, but that voltage was not reaching the grid of the tube.

The *tuned circuit* was evidently the crux of the problem; either it was "short-circuited" by some *absorption effect* or the induced voltage in it was being nullified by some other counter-induced voltage. Removing all possible coupled absorption circuits did not eliminate the fault. The remaining possibility, while it seemed far-fetched, was evidently true. *The magnetically induced voltage was being cancelled by a voltage that was most probably induced by capacity coupling.*

The solution was simple and obvious—the direction of winding of the detector grid coil was reversed; thus reversing the phase of the magnetically induced voltage. Instead of the voltages "bucking" at the dead-spot frequency, they now added and the dead-spot effect was eliminated. This peculiar type of dead-spot cannot always be eliminated so easily and the preferable way of ousting it would be to eliminate the undesirable coupling causing it.

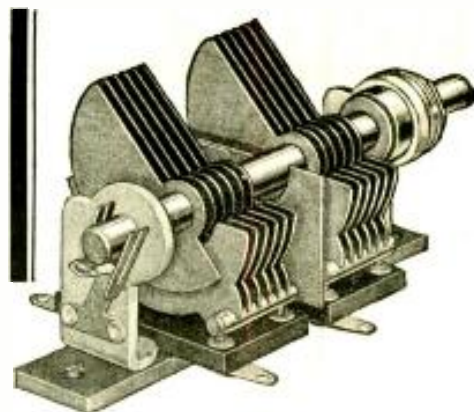

In The POLICE CALL THRILLER

One efficient unit of The POLICE CALL THRILLER is the Hammarlund two-gang, 140 mmf. Condenser. Designers of special circuits protect their personal reputations by using parts of utmost reliability. That is why Hammarlund Condensers, Isolantite Coil Forms and Sockets, Chokes and Shields are preferred by radio experts.

Write Dept. SW-5 for descriptive data.

HAMMARLUND MFG. CO.
424-438 West 33rd St.
New York

For Better Radio
Hammarlund
PRECISION
PRODUCTS

You Can Become a Fast, Capable
RADIO OPERATOR at Home

CANDLER Scientific Method

In less than the usual time you can get amazing results.

Thousands of fast Radio operators taught by CANDLER. FREE advice if you're "stuck." All questions answered personally. No obligation. If you are now a Radio operator ask about **ADVANCED COURSE** for SPEED and Copying Behind, and "MILL" Course. FREE BOOK will save you time and money. Tune in on Candler Short Wave Station!

CANDLER SYSTEM CO., Dept. S.W.7
6343 So. Kedzie Ave. Chicago, Ill.

World's Only Code Specialist

"Passed amateur exam with 3rd lesson."—E. Miller, Toledo, Ill.
"Studied 11 hours, can copy 8 w.p.m."—E. J. Yarris, Chicago.



Cash For Your
SHORT WAVE IDEAS
See Page 11

Universal Model "X"

Startlingly
NEW!

2-BUTTON
MICROPHONE \$10



Advanced 1932 superiority at today's rock-bottom prices. Same high standards, same exclusive features. Pure gold contacts. Duralumin diaphragm. Is exceptionally rugged. Model X sets a new high standard for quality at a price that defies competition. For sale by dealers everywhere. New Catalogue with diagrams now ready.

Universal
Microphone Co., Ltd.
424 Warren Lane
Inglewood, Calif., U.S.A.

SERVICE MEN!

YOUR RESISTOR PROBLEM SOLVED
with the
RADISTOR KIT
CONTAINING EVERY
Resistor That You Need!

Always on Hand for Quick Use
Contains a Resistance Value for Any Service Job



Twenty-four of the finest quality, 1 watt, R. M. A. color-coded Carbon resistors that take care of practically every replacement need. Kit contains one, each, of the following resistances: 100; 250; 400; 500; 800; 1,000; 2,000; 3,000; 4,000; 5,000; 6,000; 10,000; 15,000; 20,000; 25,000; 30,000; 50,000; 60,000; 75,000; 100,000; 250,000; 500,000; 1,000,000; 2,000,000 ohms. Can be hooked in parallel or series to provide great range of resistances. GUARANTEED accurate to within 10% plus or minus, most of them are within 5% plus or minus. Fine quality that insures a first class repair job and a satisfied customer.

FREE COLOR CODE CHART included. Always valuable to a serviceman. No ohmmeter is needed to determine the value of resistors. GREATEST VALUE. Nothing ever before offered equals this

Be sure to get your copy of our New Free Wholesale Radio Supply Catalog. **\$2.75 net**

value. You cannot afford to risk your reputation or waste your time using "old-let" resistors when you can get 24 of the very finest, select quality, carbon resistors obtainable for only \$2.75.

Place your order NOW. For the small purchase price of \$2.75 you will receive the finest kit of resistors ever offered. At no extra cost to you we will include the necessary simple formulas you need to find the value of resistors when hooked either in parallel or series.

DON'T WAIT — SEND FOR THEM NOW!

Order direct from this Advertisement!
CASH WITH ORDER OR C.O.D.

FREE! The RADOLEK CO.
601 W. RANDOLPH ST.
CHICAGO, ILL.

Please send me RESISTOR KITS at \$2.75 Net. Plus Postage.

Copy New 1932 Serviceman's Wholesale Price Guide (Attach your professional card).

Name
Street
City State

THE RADOLEK COMPANY
105 CANAL STATION CHICAGO, ILL.

All You Need to Learn TELEGRAPHY
Morse or Continental with **Teleplex**

LITERALLY thousands of ambitious men, women and boys have mastered code this easy way—right in their own homes without any other training than TELEPLEX gives them.

TELEPLEX is more than a machine—it is a SYSTEM.

All you need is an ear to listen and a hand to practice. You can't help learning to read and send just as the experts do.

TELEPLEX teaches Morse or Continental Code—equips you efficiently for amateur work or for a good-pay operator's position.

TELEPLEX—the Master Teacher—is used by the U. S. Army and Navy and by leading radio and telegraph schools.

Write for Folder SH-1

Teleplex Co.
76 Cortlandt St.
New York



5-Meter Receivers

By A. BINNEWEG, JR.

(Continued from page 33)

ences between tubes at these frequencies that several tubes ought to be tested and the best one used. It would be best, perhaps, to use one particular detector tube and build up the receiver around it. The type '12 tube will operate quite effectively at even the highest frequencies, although its internal constants are somewhat higher. If an '01A is used, somewhat larger coils can be used than are shown in the photograph of the completed receiver. The coils in the set are about 3 inches in diameter. One can use this size to start with; don't expect the wave to be near five meters, just because you used coils like those shown in the receiver. The chances are that the set will operate nearer 10 meters than 5, at first.

To operate an amateur station at five meters, first build up a simple transmitter, using the circuit suggested in Fig. 3. Use two 50-mmf. midget condensers in the oscillating circuit. A coil consisting of a four-inch loop of copper tubing will give approximately the correct wavelength, if the leads are kept short. Since the two midget condensers in the oscillating circuit are in series, quite high voltages can be employed in this transmitter without spark-overs. The grid-leak is 10,000 ohms and the grid choke consists of a 30-turn coil on a 1-inch diameter tube; the plate choke may be the same size. Filament chokes may be required; use heavy wire in these latter chokes, otherwise the filament voltage will be cut down too far. Sometimes it is difficult to tell whether a set is oscillating or not at these frequencies; for this reason a plate or grid meter will be necessary. When the set is oscillating, moving the hand near the inductance will cause a change in the meter deflections. Meters are necessary for calibrating a frequency-meter.

With a transmitter assembled and a plate or grid meter included in its circuits, set up a pair of parallel wires, about 25 feet long, spaced 2 inches apart. Short the wires at the end to which the oscillator is to be coupled, and leave the other end of the "line" open. Couple the oscillator to the "shorted" end and move a *shorting link* along the wires. The meter in the transmitter will flick at certain definite positions along the

wires; the distance between two such points is *one-half wavelength*. If these distances are measured with a meter-stick, multiplying by 2 will give the wavelength in meters. By changing the wavelength of the transmitter, the frequency meter can be calibrated.

With a calibrated frequency-meter, the receiver can be adjusted to tune over the desired range.

Use raw A.C. on the transmitter and use a small tuning condenser in the receiver; otherwise it will be difficult to pick up the signals. The tuning condenser may be a nidget variable condenser cut down to two plates. A 50-mmf. regeneration condenser will give good control over a wide range, if the tickler coil is properly adjusted. Adjust the distance between tickler and secondary coil until the proper control is obtained.

Results at 5 Meters

Unusual results are obtained at 5 meters! It will be noticed that every little hill—in fact even houses, etc.—will cast a *radio shadow*. In one set of experiments, no aerial was employed at either the transmitter (7½-watt tube in the circuit of Fig. 3, with 300 volts on the plate) or at the receiver, and the signals were still strong on a hill about 10 miles from W6BX. At this point (the receiver was in the back of the car), the signal strength was the same, no matter which way the set was turned. One would expect the coils in the set to act like loops, but the pick-up in the leads probably masked any such effect.

On one occasion, an 852 tube (with about 500 watts input!) was operated in the 5-meter band, but listening tests across the bay (about 20 miles distance) gave no results. At that time, a rather rough signal was picked up in the receiver. We were at a loss to explain it, until it was noticed that it disappeared when the lights in the shack were turned out. Upon investigation it was discovered that a nearby light bulb was sending out a signal close to 5 meters! By simply screwing the light bulb into or out of the socket, the wavelength of this "transmitter" could be changed. It may have been an exceptional light bulb; but the effect was interesting.

At Last—Oliver Amlie's "DX" Receiver Circuit

(Continued from page 17)

- 4—No. 12a Pilot condenser couplings for shafts.
- 9—Burnt out tubes, 4 prong, also tubing for No. 5, 6, 7, 8 and 9 coils.
- 1—Bottom base-board, 8 by 21".
- 1—Carter No. 2 filament switch, Catalog No. 2396.
- 1—Bakelite panel or hard rubber, 7 by 21 inches.
- 3—45 volt Eveready (or other) heavy duty "B" batteries.
- 1—6 volt Storage battery.
- 1—7-Wire cable.
- 1—Double-throw, double-pole switch.
- 7—Binding posts.
- Spools No. 20 D.C.C., 26 D.C.C., 28 D.C.C.
- 2—Porcelain Insulators.
- 140 feet No. 14 double rubber covered antenna.

- 2—Copper strips for antenna lead-in; also home-made condenser, S5, (optional; use 25 to 50 mmf. midget variable condenser—Editor).
- Battery cable, hook-up wire, screws, nuts, solder, etc.

Amlie Coil Winding Data

- Coil
- 1—S-4 turns No. 20 D.C.C. 18 to 26 meters
 - T-11 turns No. 26 D.C.C.
 - 2—S-5 turns No. 26 D.C.C. 26 to 35 meters.
 - T-14 turns No. 26
 - 3—S-9½ turns No. 26 D.C.C. 35 to 49 meters
 - T-16 turns No. 26
 - 4—S-11 turns No. 26 D.C.C. 49 to 75 meters.

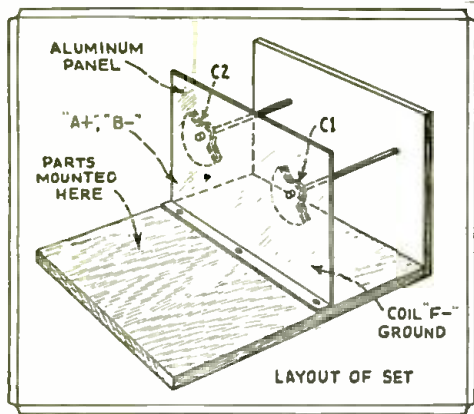

How midget condensers are mounted in Amlie receiver.

A Crystal Detector Super

By R. WM. TANNER

(Continued from page 35)

the I.F. screen grid or plate leads, it will undoubtedly be better for the set-builder to include them, otherwise oscillation may occur. These are shown in the circuit diagram in fig. 2.

Volume Control

Volume is controlled in the I.F. amplifier by connecting the cathode leads to the slider on a 50,000 ohm potentiometer, through a 200 ohm fixed "bias limiting" resistor. The potentiometer is connected from 75 B+ positive to B negative.

Since it would be impossible to obtain a voltage divider having fixed taps which would give the correct voltages, the set-builder should purchase a 25,000 ohm, 75 watt Truvolt resistor, as employed in the original model. Slider taps may be purchased to fit this resistor, three being needed for 45, 75 and 180 volts. Bypass condensers of at least .5 mf. should be connected from each tap to B negative.

Power Supply

The power supply may be any "ready made" unit which will deliver at least 300 volts at full load. If the power unit is constructed, be sure and obtain a transformer with 350 to 400 volts on each side of center, and having filament windings of proper carrying capacity. The filter chokes should be good ones of 30 henries, with a carrying capacity of at least 100 M.A. In an experimental set such as this one, it would be wise to use paper filter condensers of 600 volts rating, rather than the electrolytic type, which can burn out rectifier tubes if the load happens to be removed, while line switch is on. The writer has seen this occur many times with experimenters. When the load is removed, the peak voltage rises to a value above the rating of the electrolytic condenser which causes a direct-short across the rectifier output. In nearly every case it is impossible to turn off the line current before the rectifier filament burns out, and then the experimenter places the blame on the tube.

How to Test and Adjust Set

Testing this set and making the necessary adjustments is not as complicated as might be imagined. When completed, the broadcast coils should be plugged in and tuned to a station at the low end of

- T-20 turns No. 26
 - 5—S-20 turns No. 26 D.C.C. 75 to 100 meters
 - T-34 turns No. 26
 - 6—S-35 turns No. 26 D.C.C. 100 to 135 meters
 - T-67 turns No. 26
 - 7—S-51 turns No. 26 D.C.C. 135 to 185 meters
 - T-83 turns No. 26
 - 8—S-74 turns No. 28 D.C.C. 199 to 560 meters
 - T-65 turns No. 28 D.C.C.
 - 9—S-228 turns No. 28 D.C.C. 560 to 900 meters
 - T-145
- Coil No. 5 and .0005 mf. condensers will take care of from 185 to 199 meters; this is to save from winding another coil.

the scales. Even though the circuits are not yet peaked to resonance, a strong signal may be picked up easily; then adjust the I.F. trimmers to maximum volume. Now carefully re-set the band-pass and oscillator dials and adjust the trimmers in the band-pass coils again for maximum signal strength. These last adjustments should be made with the first detector regeneration control set a few points below oscillation. The tapped coil in the R.F. grid should, of course, be set at the proper point (all turns in circuit). After the broadcast coils are tested, plug in the television band coils (100 to 200 meters) and go through the same procedure as before and down through the 80, 40 and 20 meter bands.

COIL DATA TABLE

Band	L1	L2	L3	L4	L5	L6	L7	L8
Broadcast	115	4	4	115	30	10	90	30
Television	50	2	2	50	15	6	41	15
80	23	2	2	23	8	4	18	9
40	12	1	1	12	6	2	10	7
20	5	1	1	5	5	2	5	4

In the coils for the broadcast band the P and G prongs are bridged together with a short length of wire. This applies to the band filter but not the oscillator.

Data Applying to Fig. 2

- C —.00005 to .0001 mf. antenna condenser
- C1 —.1 mf. bypass condensers
- C2 —Band filter tuning condensers (.00014 mf.)
- C3 —Band filter tuning condensers (.00035 mf.)
- C4 —.00001 mf. 1st detector grid condenser
- C5 —.00001 mf. feedback condenser
- C6 —.00025 mf. oscillator tuning condenser
- C7 —70 to 110 mmf. Hammarlund compensating condenser
- C8 —.00025 mf. oscillator grid condenser
- C9 —70 to 140 mmf. Hammarlund compensating condensers
- C10 —.0001 mf. I.F. coupling condensers
- C11 —.00025 mf. 2nd detector bypass condenser
- C12 —1 mf. bypass condensers
- R —500 ohm R.F. bias resistor
- R1 —2 megohm 1st detector grid leak
- R2 —50,000 ohm regeneration control
- R3 —10,000 ohm oscillator grid leak
- R4 —5000 ohm volume control
- R5 —200 ohm I.F. bias limiting resistor
- R6 —2 megohm I.F. grid resistors
- R7 —5000 ohm I.F. filter resistor
- R8 —100,000 ohm I.F. plate resistor
- R9 —200,000 ohm resistor
- R10 —100 ohm A.F. bias resistor
- R11 —100,000 ohm A.F. plate resistor
- R12 —250,000 ohm A.F. grid resistor
- R13 —25,000 ohm A.F. filter resistor
- R14 —25,000 ohm Truvolt voltage divider with 3 taps
- RFC —S-M 277 R.F. chokes
- RFC1 —S-M long wave R.F. chokes
- AFT —2 to 1 A.F. transformer
- OT —Output transformer

Radio's Future

... and YOUR future in radio



GET your training at a radio school that is recognized as a leader—RCA Institutes. It is America's oldest radio school—founded nearly a quarter century ago. Many of its graduates now hold responsible positions with the largest radio companies. When you learn at RCA Institutes you are sure your training is right. Four big resident schools—New York, Boston, Philadelphia, Chicago. Extension courses for home study. Experienced teachers. Up-to-date equipment. Great variety of courses, both elementary and advanced, in practical radio. Association with radio's largest research laboratory. You can choose courses fitted to your own needs. Tuition low. Mark and mail coupon now for catalog and full details.

A Radio Corporation of America Subsidiary

RCA INSTITUTES, INC.
Dept. CS6 75 Varick St., N.Y.
Please send me your General Catalog.

I am checking below the phase of radio in which I am interested.

Microphone Technique Talking Pictures

Broadcast Station or Studio Servicing Home Entertainment Equipment

Aviation Radio

Radio Operating Television

Name.....

Address.....

Occupation..... Age.....

Cash for Your
SHORT WAVE
IDEAS
See Page 11

Wireless or Wire TELEGRAPHY

QUICKLY LEARNED AT HOME

HERE IS EVERYTHING YOU NEED TO ACQUIRE EITHER OR BOTH CODES:

Instructograph, Code Transmitter, 10 Rolls of Tape (2,000 feet mtr.), Complete Book of Instruction (Both Codes).

Extra Tapes.
No matter how little you know about Wireless or Wire Telegraphy—whether your desire to learn is for profit or pleasure—this remarkable Code Instructograph plus our Complete Book of Instruction will quickly make you proficient in either or both codes right in your own home. Saves time, money and effort. Now is the time to get started. Learn the easy way. Write at once for particulars and prices.



INSTRUCTOGRAPH CO. - Dept. SW-7
912 Lakeside Place Chicago, Ill.

GET POLICE CALLS

on your Present Radio by attaching a BUD POLICE THRILLER to it.

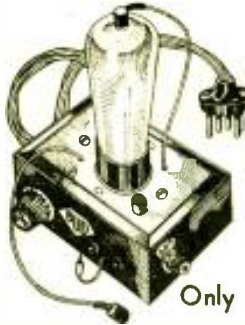

You can listen to Police Calls, Riot Calls, Naval Stations, and Amateur Stations. Fits any Electric Radio. Easy to Install.

Only \$3.50

BUD POLICE THRILLER when connected to broadcast receiver changes the tuning from 80 to 200 meters on the broadcast receiver. This will enable you to bring in short wave reception in addition to your regular broadcast programs. Guaranteed to work on your Radio Set or money will be refunded.

BUD RADIO INC.

1923 E. 55th St. Cleveland, Ohio

F. & H. CAPACITY AERIAL



Price \$1.00 Complete postpaid

Every Instrument Tested on Actual 1127 Mile Reception A LARGE NUMBER ARE IN USE BY GOVERNMENT, IN NAVY HOSPITAL

The F. & H. Capacity Aerial Eliminator has the capacity of the average 75-foot aerial, 50 feet high. It increases selectivity and full reception on both local and long distance stations is absolutely guaranteed. It eliminates the outdoor aerial along with the unsightly poles, guy wires, mutilation of woodwork, lightning hazards, etc. It does not connect to the light socket and requires no current for operation. Installed by anyone in a minute's time and is fully concealed within the set. Enables the radio to be moved into different rooms, or houses, as easily as a piece of furniture.

8,000 dealers handle our line. Dealers! Over 80 leading jobbers carry our line or order sample direct. Write for proposition.

SEND COUPON. IT PROTECTS YOU

Name
Address
City State

Send one F. & H. Capacity Aerial with privilege of returning after 3-day trial if not satisfactory, for which enclosed find check M. O. or dollar bill, or send C. O. D. Send Literature. Dealer's proposition.

F. & H. RADIO LABORATORIES Dept. SW Fargo, N. Dak.

RADIO PHONE AMATEURS!

Let's Get Organized ... See Page 18 ...

You Can Enjoy Real Comfort With This Receiver Layout

By ROBERT "BOB" HERTZBERG W2DJJ

(Continued from page 31)

jacks. These are connected in series across the secondary of a 1:1 ratio output transformer. The jacks are mounted under the table so as to keep the phone cords out of the way of the operator's hands and elbows, and two of them are used to permit the use of two pairs of phones. With good phones costing less than a dollar and a half a pair today, the writer has found it very useful to keep two pairs on hand, to accommodate the visitors who must be impressed with the wonders of the short waves, even when unobliging stations are not strong enough to agitate the loud speaker.

Also mounted under the table, slightly to the right of the set, is a regular porcelain-base snap-switch. This is the "on-off" switch for the receiver, controlling the 110-volt A.C. line to the primary of the filament transformer. This transformer and the "B" batteries are placed on a small wooden stand pushed against the wall under the table. Both the A.C. and D.C. connections are thus very short and easy to make.

The "Control Box"

The "control box" consists merely of a small bakelite panel bearing a double-pole, double-throw key switch, a red "pilot" light, and a regular single-pole, single-throw snap switch. The construction is simple and is made clear in Fig. 2. All the connections are shown in Fig. 1.

The arms of the double-pole switch connect to the two "output" binding posts on the receiver (or to the phone jack). The lower contacts connect to the primary of the aforementioned output transformer, the purpose of which is to keep all D.C. out of the phones. The upper contacts are wired to the primary of the push-pull input transformer. The snap switch goes in the power circuit of the amplifier's power-pack, in this case a Pilot K-112 unit. The pilot light, using a 2.5-volt lamp, goes to one of the idle 2.5-volt filament secondaries on the pack. The audio amplifier itself is of perfectly standard construction. Complete with power-pack it mounts on a piece of shelving only 12 x 7 1/2 inches,

Real Comfort at Last

The comfort and flexibility of this layout have been praised by every short-wave fan who has seen and used it. You sit down, push your feet under the table, and snap on the receiver switch, which you find without effort, just where your right hand rests in your lap. The dial lights up, so you know the set is alive. You pick a pair of phones off the hook under the table and plug them into the jacks you find conveniently next to your left leg. The cord dangles free, and does not get mixed up with the "log book" or curled up in your elbows. You snap on the amplifier "power switch," just to warm up the tubes, and the red pilot tells you that the "juice" is on. You push the "key switch" down, and

(Continued on page 60)

Two combined SHORT WAVE and Standard Broadcast Superheterodyne Radio Receivers



The CROSLY DISCOVERER

With this marvelous new Crosley radio receiver you can know the thrill of listening direct to foreign stations, air pilots receiving instructions, police calls and many other interesting and unusual things that travel the short wave bands. Every channel from 14 to 550 meters is covered. Of course ordinary broadcasts can also be heard. It is housed in an extraordinarily beautiful cabinet and sells at a sensationally low price.

\$77.50 COMPLETE WITH 7 TUBES



The CROSLY ADVENTURER

The 12 tubes of this Crosley superheterodyne short-wave and standard broadcast receiver make it, we believe, the most sensitive, best performing and most complete set ever offered at any price for home reception. The wave length change, as in The DISCOVERER, is effected by means of a panel switch — no coils to change. The cabinet is a marvel of furniture design. The price is amazingly low.

\$119.50 COMPLETE WITH 12 TUBES

Montana, Wyoming, Colorado, New Mexico and west, prices slightly higher.

THE CROSLY RADIO CORPORATION Home of "the Nation's Station"—WLW Powel Crosley, Jr., President Cincinnati



SWAPPERS

SWAPPERS are swappers of correspondence. During the past few years we have noted that Short-Wave enthusiasts love to get acquainted with each other by mail in order to swap experiences. Use a postcard only. Never write a letter. Address postcard as follows:

SWAPPERS
c/o SHORT WAVE CRAFT
96-98 PARK PLACE
NEW YORK, N. Y.

On the blank side of the postal PRINT clearly your name, address, city and State. Don't write anything else on card. We will then understand that this is your request to publish your name and address and that you wish to enter into correspondence with other short-wave readers. There is no charge for this service.

—EDITOR.

- BLAISE S. ABRUSCATO
1307 Washington Ave., New York City
- HAROLD F. ALPAUGH
R. D. No. 1, Annandale, New Jersey
- JOSEPH A. ARKO
3326 Salmon St., Philadelphia, Pa.
- PAUL T. BAUMAN
3520 35th Avenue So., Minneapolis, Minn.
- ALBERT O. BELLENGER
252 Somershire Drive, Rochester, New York
- MARTIN BERNSTEIN, W9BON
3940 Grenshaw St., Chicago, Illinois
- ERNEST O. BERTRAND
2101 Linwood, Kansas City, Mo.
- VICTOR C. BESANCON, W5CD
115 Grant Ave., San Antonio, Texas
- KENNETH BLOCK
870 Riverside Drive, New York City
- F. BRIGO
1927 No. 2d Street, Philadelphia, Pa.
- IRVIN H. BUCK
R. D. No. 1, Box 16, Harrisburg, Pa.
- JASPER CALCARA
1104 E. Missouri Ave., Kansas City, Mo.
- F. CARITHERS, Jr.
42 Beverly Rd., Great Neck, New York
- MILTON E. CHAFFEE
P. O. Box No. 37, Milldale, Connecticut
- KENNETH CONN
Box 87, Gans, Pa.
- EDWIN A. DA VAULT
P. O. Box 93, Ferndale, Md.
- GERARD J. DONAHUE
2319 E. Harold St., Philadelphia, Pa.
- J. WARREN DONAHUE
1326 Oak St., Los Angeles, Calif.
- WALTER E. DUNLAP
Alexandria, Ohio
- MARTIN ELLIS
R. F. D. No. 3, Brunswick, Ohio
- EDWIN ERLER
2472 Grand Ave., Bronx, N. Y. C.
- ALBERT EVANGELISTA
536 Union Ave., Belleville, N. J.
- HARRY FARBBER, W8—
216 Monroe St., Syracuse, N. Y.
- RUSSELL FOISY
481 Park Ave., Worcester, Mass.
- EDOLA J. FORTIER, W1ACG
Grovelton, N. H.
- JOHN G. FRANTZREB
3226 E. 25th St., Indianapolis, Ind.
- "BILL" GOODWIN
204 Holmes St., Belleville, N. J.
- CLARENE GRIMM
Mt. Prospect, Illinois
- WILLIAM GROVES
229 Maujer St., Brooklyn, N. Y.
- ROBERT HAMMOND
1426 Main St., Parsons, Kansas
- CHARLES H. HARRIS
2129 Woodberry Ave., Baltimore, Md.
- PAUL HERMAN
1119 Wilcox St., Hammond, Indiana
- ROBERT W. HOLLY, Jr.
28 Royce Ave., Middletown, N. Y.
- VERNON HORNING, W7BNX
Box 306, Richland, Ore.
- GEORGE V. HORTON
Box 175, Wood, Penna.
- WILMOT HUNT
P. O. Box 16, Joseph, Oregon
- EDWIN IDLITT
5324 Rolston Ave., Norwood, Ohio
- CHARLES JIRSA
3587 East 103rd St., Cleveland, Ohio
- EUGENE KAARI
R. F. D. 1, Box 104, Hurley, Wisconsin
- JULIUS KLEINMAN
1494 Brook Ave., Bronx, New York City
- AL. M. KRESOJA
2163 West 29th St., Cleveland, Ohio

- ADAM KRISER,
2025 E. Huntingdon St., Philadelphia, Pa.
- STANLEY T. LADAGE
923 No. 27th St., Camden, N. J.
- DOUGLAS LAMY, (2nd Opr. W1AU'B)
993 Summer St., Stamford, Conn.
- NORMAN H. LATSHAW
521 Grant St., Franklin, Pa.
- IVER H. LAWSON
117 Beech St., Belmont, Mass.
- WILFRED M. LIERHEIMER
112 Franklyn Ave., Sea Cliff, New York
- LOUIS A. LOREE
2118 4th Ave., Bay City, Michigan
- ARNOLD McNATT, W5BBS
1101 No. 12th St., Fort Smith, Ark.
- LEONARD MACOMBER
97 Crest Rd., Wellesley, Mass.
- WALTHER E. MARIEN
3355 No. 2nd St., Milwaukee, Wis.
- ARCHIE J. MAUS
2204 No. 15th St., Terre Haute, Ind.
- EUGENE S. MIDDLETON
Route A, Box 61, Ceres, California
- JACK MILLER
5 E. Genesee St., Auburn, N. Y.
- JOHN NOBLE
144-10 Hillside Ave., Jamaica, N. Y.
- EDWARD O'COLE
2714 Warren Blvd., Chicago, Illinois
- KENNETH PATTERSON
121 E. Grand River Ave., East Lansing, Mich.
- SID POKONNY
702 Cleveland St., Watertown, Wisc.
- JAMES O. PROCTOR
1305 N. Broadway, Baltimore, Md.
- A. L. ROSENE, Jr.
2815 Caroline St., St. Louis, Mo.
- FRANK J. SADILEK
4600 University Ave., Des Moines, Iowa
- BERT J. SHERBERT
438 So. 4th Ave., Saginaw, Mich.
- STEVE SJOLAND
6433 N. Paulina St., Chicago, Ill.
- NED A. SOSEMAN
Bloomfield, Iowa
- B. STENSON
2441 Jerome Ave., Bronx, New York City
- C. M. STEVENSON
135 Washington Pl., Hasbrouck Heights, N. J.
- THEO. O. THOMPSON
U. Station, Box 173, Grand Forks, N. D.
- TREGOF SHORT WAVE LAB.
Adamstown, Pa.
- EDWARD J. TRELLA
547 Broad St., Meriden, Conn.
- GEORGE USHER
138 Wende Ave., Buffalo, N. Y.
- E. VALENTINI
101-11 Roosevelt Ave., Corona, L. I., N. Y.
- JOHN J. WEITZMANN
2111 E. Huntingdon St., Philadelphia, Pa.
- J. F. WISE, Jr., W3AIZ
18 N. Oak Ave., Clifton Heights, Pa.

Simple Transmitters and Receivers for U.S.W.

By KURT NENTWIG

(Continued from page 13)

Loud Speaker Signals

To reproduce the reception in the loud speaker as well, an audio-frequency amplifier was experimentally connected to the receiver. Fig. 9 gives a picture of this design. Receiver and amplifier are advantageously run entirely by batteries, in order not to get oscillations from the lighting circuit with which the transmitter is, of course, connected.

In using a dipole one must pay great attention to its correct position with regard to the transmitter; since otherwise (because of the strongly marked directional effect), the reception is under certain circumstances only "soft" or mushy. When dipoles were used in the writer's experiments at transmitter and receiver, they were both arranged vertically, to eliminate difficulties right at the start.

It should also be mentioned that, with the sets illustrated the writer also performed television experiments, which came out very satisfactorily. The ultra-short waves will perform good service in this field also.—Rafa, H. 5, 1931.

RADIO FANS

save TIME MONEY

with **CLAROSTAT ad-a-switch VOLUME CONTROLS**

You need never be stuck in an emergency if you use AD-A-SWITCH. You can convert from plain to switch control in a jiffy. Snaps on without tools. Ask your jobber or write us direct.

FREE! Write for your copy of the most complete handbook on every type of variable resistance—from tiny Center Taps and Volume Controls up to Heavy Motor Speed Controls.

Every experimenter, service man and engineer should have a copy of the CLAROSTAT Control Handbook.

CLAROSTAT Mfg. Co.
285-287 N. 6TH ST. BKLYN. N.Y.

The New Improved "AIR CRUISER" Short Wave Adapter. Get all the police thrills, murders, suicides, holdups, kidnaping, fires, etc. Also many amateur phone and code stations. The only adapter you can switch from Short Wave to Broadcast without changing Aerial Wire. Price \$2.50. We will send sample prepaid anywhere in world for \$2.25 cash with order.

BRECKENRIDGE MFG. CO.
3753 West Warren Avenue Detroit, Michigan

PATENT YOUR IDEAS REGISTER YOUR TRADE-MARK BY

Z. H. POLACHEK
1234 BROADWAY
31st. NEW YORK

DO IT NOW
REG. PATENT ATTORNEY PROF. ENGINEER

WHAT IS YOUR INVENTION?

Send me a simple sketch or model for CONFIDENTIAL ADVICE

"For METER'S Sake" USE LITTELFUSES



Assorted carton of 50 Instrument Littelfuses and 10 mountings. Contains 6 sizes, protecting any meter from the smallest galvanometer to a 0-1 ammeter. Saves its cost on one instrument of a good meter. Complete directions on carton and in instructive catalog 4-H. Cash orders post-paid. Price Complete \$8.30

Littelfuses also made in high voltage ranges for transmitter tubes, etc. See your dealer or jobber.

LITTELFUSE LABORATORIES
1768 Wilson Ave., Chicago

Shortwave Molded Coil Forms

Four or five prongs. .25c each
Molded sockets with locator ring

- Base mounting 481X
 - 4 prong 25c
 - 481Y 5 prong 25c
- 474 Laminated socket 4 prong 10c

475 Laminated socket 5 prong.10c
Ant-Gnd Binding Posts10c



949 KCT Disc adapter for bringing out filament and plate from pentode tube to provide filament and plate voltage for operating short wave converters60c

Adapters to provide any type connections desired. Write your requirements.

3-4-5-6 Prong Speaker or Cable Plugs
905L Latch Lock Analyzer Plugs

Five prong \$3.00
with 5-foot cable. 5.00
954DS Adapter to use with 905—with center locking stud 1.25

954KPC Pentode Adapter
Connects cathode to plate



Used for replacing 245's with 247 Pentode tubes 1.00
247 Pentode Tubes 1.00
954FKP Pentode adapter with resistance in filament reducing 5 volts to 2.5. For putting 247 Pentode tubes in 171 sockets. For push pull, resistance discards and filaments are connected in series 1.25

Send for Price Sheets—Dept. N

Alden Manufacturing Co.
BROCKTON, MASS.

You Can Enjoy Real Comfort With This Receiver Layout

(Continued from page 58)

the phones immediately wake up. You fish around in the usual manner, and observe the absence of background noise, the smoothness of regeneration, the clean character of the signals—the result of the A.C.-D.C. power combination and the use of the phones in the first audio stage. You pick up a strong carrier, clear it up and hear voice or music. Flip up the key switch, and there is the station in the loud speaker without further fuss. The phone plug doesn't have to be pulled out, the set returned, or the regeneration control readjusted, all of which operations are necessary in three sets out of five.

You can do your tuning with the loud-speaker on, of course. However, other members of the family may object to the heterodyne whistles, the powerful code signals or the automobile ignition interference, even though they like to hear Italy or Colombia. In the quiet of the night these sounds always seem very loud, and are likely to disturb people.

Idea Adaptable to Complete Station

The physical and electrical details of this suggested arrangement can readily be changed. There is no reason why the amplifier cannot be hidden out of sight under the table, along with the power supply units. The control box may be placed next to the set, and may hold the set's power switch as well as the amplifier controls. A friend of the writer, following these ideas, built a complete amateur station (receiver and transmitter) on and below an ordinary bridge table. Nothing shows on top except the small receiver, the control box (which includes still another small snap switch for the transmitter), and the transmitting key.

If the owner of a complete receiver (amplifier built in) wishes to use the switch "cut-in" idea, he can do so by changing only a few connections in the first audio circuit. It is important to isolate the phones from all high voltages, for the reason already mentioned. In some sets, blocking condensers can be made to serve the purpose; in others a 1:1 ratio transformer is better. In all cases be careful not to leave any grid circuits open. If the bias is removed from the power tube or tubes, particularly, the plate current shoots way up and both tubes and power-pack are sure to suffer.

5 Meters and Below! By R. RAPCKE

(Continued from page 29)

Wire rec-tangle LA	Wire rec-tangle LG	Heating Cur-rent. Amp.	Wave Length. Meters
Width cm.	Height cm.	Width cm. Height cm.	
38.5	18.4	21.8 10.2	2.40 7.10
38.5	18.4	17.0 10.2	2.40 6.88
38.5	18.4	14.0 10.2	2.40 6.72
38.5	18.4	26.0 6.7	2.40 6.84
29.0	18.4	26.0 6.7	2.40 6.16
34.0	18.4	25.0 6.7	2.60 6.20
24.5	18.4	17.0 8.7	2.60 5.60
22.5	18.4	15.5 6.7	2.70 5.20

Note: 1 cm. = .4 inch.

With the same hook-up Huxford worked down to 2 meters!—(Funk Bastler.)

EFFICIENT PHOTO CELLS CAN NOW BE BOUGHT AT LOW COST

THE NEW LUXTRON KIT HAS THOUSANDS OF PRACTICAL APPLICATIONS including

COMPLETE KIT \$9.50

REQUIRES NO AMPLIFIERS. (Never Before Sold for Less Than \$60)

This Includes:

- 1 Light Sensitive LuxTron Cell, type "ST."
- 1 Relay, Controlling 110-Volt Circuit, type R-1.
- 1 Gum-Wood Relay Cabinet.
- 1 Complete Set Instructions and Diagrams, showing How to Make Automatic Parking Light Control for Automobiles.

Size 6" x 3 1/4" x 3 1/2" deep. LUXTRON R-1 RELAY (shown above in case)

ONLY \$4.00 less case

LUXTRON MFG. CO., INC.
241 Lafayette St., Dept. SW., N.Y. City
Pioneers in Photo-Cell Devices Since 1900

Send \$1 Only for interesting instructions and diagrams.

CASH For Your SHORT WAVE IDEAS
See Page 11

Wireless Keys

for all commercial or amateur purposes—backed by nearly 40 years of experience. R-68 wireless practice set is popular with beginners, as it is complete with transmitting key, buzzer, code and instruction book. Write for details and prices on all types of telegraph and wireless instruments.

SIGNAL ELECTRIC MFG. CO.
Menominee, Michigan

SIGNAL

DEALERS—AGENTS WANTED

EVERYWHERE to Handle the Fastest Selling Radio Attachment on the Market Today

THE POLICE LOWWAVE CONVERTER

A new invention that is easily attached to any radio—by means of which anyone can tune in, at any time on local police broadcasting and get such thrilling—exciting—and often sensational—items as headquarters puts on the air for Radio-Police squads. Simple instructions are furnished.

SELLS FOR ONLY \$3.00

Send \$1.79 for sample, no stamps. Or if you wish, send 10c in stamps for C.O.D. order and pay postman the balance of \$1.69.

POLICE LOWWAVE LABORATORIES
1460 Huron St. Dept. 3 Toledo, Ohio

When to Listen In By "BOB" HERTZBERG

Characteristic Signals

SHORT-WAVE listeners will find it easier to identify foreign stations if they know what to expect in the way of announcements or characteristic signals. The following data on four prominent stations in different parts of the world will be of interest in this connection:

Sydney—VK2ME (New South Wales)

Wavelength, 31.28 meters, or frequency of 9,590 kilocycles. Power, 20 kilowatts. Man announcer. Opening signal, laugh of the lyre-bird, reproduced by sound film. Call or announcement: "This is VK2ME, the Australian National Empire short-wave broadcasting station on 31.28 meters." Closes down with the announcement, the bird signal and "God Save the King". Best time for reception in the United States 1:00 to 3:00 a.m. Sunday mornings. (Also see page 425 of April issue of SHORT WAVE CRAFT.)

Skamlebaek—OXY (Denmark)

Wavelength 31.51 meters, or frequency of 9,520 kilocycles. Power, 500 watts. Man announcer. Opening signal, music box melody. Call, "Kobenhavn, Kalundborg og Danmarks kortbølgesender." Closes down with the words, "Hermed er programmet slut for iaften: vi meddele dem programmet for i morgen." (Here with we close our today's program: we give you tomorrow's program.) "Glen ikke at soette antennen" ("Remember to ground your aerial"). God Nat, God Nat ("Good night, good night"). Broadcasts daily starting at 2:00 p.m., E.S.T., until about 7:00 p.m.

Chi-Hoa—F3ICD (Saigon, French Indo-China)

Wavelength, 49.05 meters, or frequency of 6,116 kilocycles. Power, 12 kilowatts. Has both man and woman for announcers. Call, "Allo! allo! Ici Radio Saigon." Announcements and news bulletins are given in French, English and Chinese. Opening and interval signal is a gong. Broadcasts daily except Wednesday from 6:30 to 10:30 a.m. E.S.T. Closes down with a time signal and good night greetings in French and English followed by the French national anthem, "La Marseillaise".

Chi-Hoa also transmits on 25.46 meters, but this channel is reserved for a daily public radiotelephone service with Australia, Japan, the Dutch East Indies, France, Algeria, Morocco and Tunis.

Prato Smeraldo Rome—13RO (Rome)

Wavelength, 80 meters, or frequency of 3,750 kilocycles. Power, 14 kilowatts. Famous for its woman announcer. Call (phonetic), Eh-yar Rah-dee-owe Roma. Relays programs from Rome, Naples, Milan, Turin and Trieste. Operas are the usual fare. Broadcasts daily between 3:00 and 5:00 p.m., E.S.T. Closes down with the words, "Fine della trasmissione. Buona notte a tutti" ("End of transmission. Good night to all"), followed by the royal anthem, "Marcia Reale" and the Fascist hymn, "Glovinazza".

Tananarive, Madagascar

To SHORT WAVE CRAFT:

The short-wave broadcasting station "Radio Tananarive", on the island of Madagascar, transmits regularly as follows (All times E.S.T.):

Tuesday, Wednesday, Thursday and Friday, from 9:30 to 11:30 a.m.

Saturday and Sunday, from 1:00 to 3:00 p.m.

The programs consist of speeches, phonograph music, and musical concerts by native artists. The antenna power is 400 watts and the wavelength is 50 meters.

Administration des P.T.T.,
Service Radiotelegraphique,
Madagascar.

Madagascar, a French possession, is a large island off the East Coast of Africa, in the Indian Ocean.

Its Praise Knows No Boundaries!

I received your book, "How to Build and Operate Short Wave Receivers." I am very pleased with it, as I believe it is the best book that has been printed on short wave work. It is invaluable to builders of Short Wave receivers. Worth many times the price, my candid opinion.

E. H. BLADES,
Radcliff, Alberta, Canada.

50c

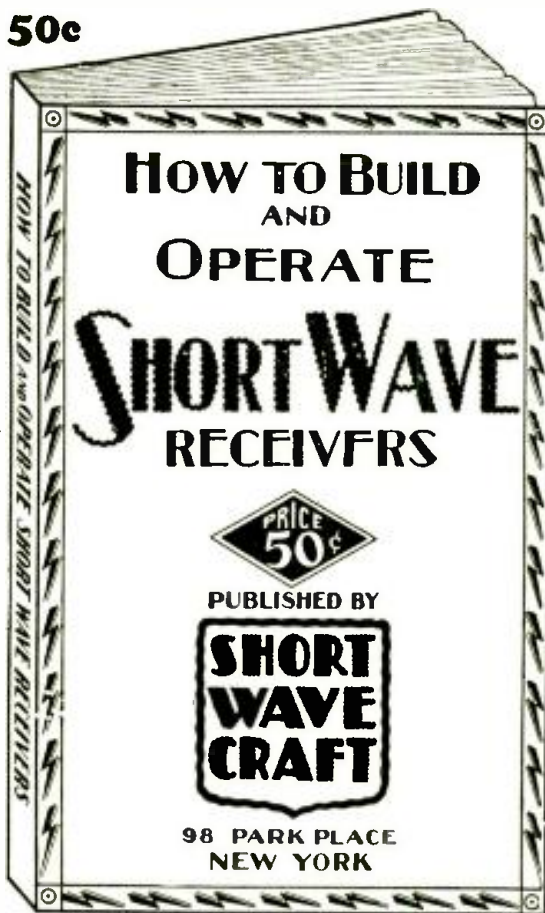

On the lips of thousands of Short Wave enthusiasts—in the shops and homes of thousands of "hams"—HOW TO BUILD AND OPERATE SHORT WAVE RECEIVERS is now recognized as the GREATEST BOOK OF ITS KIND EVER PUBLISHED.

We hear favorable comments everywhere—the other is chock full of gossip by "hams" about the Short Wave Book. Those in the "know" have written us that they have found this book most instructive and makes a valuable addition to their Short Wave Library.

EVERY SHORT WAVE ENTHUSIAST SHOULD HAVE A COPY

The book has been edited and prepared by the editors of SHORT WAVE CRAFT, and contains a wealth of material on the building and operation, not only of typical short wave receivers, but short wave converters as well.

Dozens of short wave sets to be built will be found in this book, supplemented by hundreds of illustrations; actual photographs of sets built, hook-ups and diagrams galore.

The book comes with a heavy colored cover, and is printed throughout on fine-class bound paper. No expense has been spared to make this the outstanding volume of its kind. The book measures 7½ x 10 inches.

72 pages
200 illustrations

Partial List of Contents

- | | |
|--|---|
| The "S. W. C." Two Tube Portable Works "Speaker"—Clyde Fitch | Combination Long and Short Waver—E. T. Somerset, G2DT. |
| How to Operate a Short Wave Receiver | Super Regenerative Receivers |
| Two-Volt Tube Receiver | How to Build the S. W. Superregenode—Clifford E. Denton |
| A "Plug-less" S. W. Receiver—John M. Avery | Short Wave Tuning Less Plug-in Coils—Herbert Bernard |
| "My Favorite" Short Wave Receiver—F. H. Schnell | How to Use Radio Frequency Chokes—R. William Tanner, W8AD |
| The HY-7B Super-Het for A.C. Operation—L. W. Hatry | The "Ham's Own" Receiver—Norman B. Krim |
| The "Exert" SWS-9 Super-Het—How to Make It—Joseph I. Heller | How to Use a Separate Regeneration Tube—E. T. Somerset |
| A Super Sensitive Short Wave Receiver—Thomas A. Marshall | Short Wave Converters—How to Build Various Types |
| A S. W. Power Amplifier—H. Winfield Secor | A Short Wave "Fun Box" |
| How to Obtain Smooth Regeneration in S. W. Receivers—"Bob" Hertzberg | How to Build a Good Television Receiver—R. William Tanner |

Published by the publishers of SHORT WAVE CRAFT magazine. This alone will be your guarantee that it is a really worthwhile publication.

We know that if you are at all interested in short waves you will not wish to do without this book. It is a most important and timely new radio publication.

USE COUPON

THIS BOOK IS
NOT SOLD ON
THE NEWSSTANDS

SHORT WAVE CRAFT

96-98 Park Place,
New York City.

SW-3-1

Gentlemen:—

I enclose herewith fifty (50c) cents for which please send me a copy of your new book, HOW TO BUILD AND OPERATE SHORT WAVE RECEIVERS. (Send money order, check, cash, or new U. S. Stamps. Register letter if it contains currency or stamps.)

Name

Address

City and State



Stoppani Belgian Compass

Being a precision instrument, the Stoppani Compass lends itself admirably for use in the Itadio Experimenter's test laboratory. It affords an ideal means of determining the polarity of magnets, electro-magnets and solenoids carrying current. Since the compass needle is itself a magnet, having a North-seeking pole (which is actually the South pole) and South-seeking pole (which is actually the North pole); and since, as we all know, like poles attract each other and unlike poles repel each other, it is merely necessary to bring the compass in the vicinity of the magnet under test. The North pole of the compass needle will then point to the North pole of the magnet under test or the South pole of the needle will point to the South pole of the magnet depending, of course, upon their relative positions.

May Be Used As a Galvanometer

Because of its uniform magnetic properties, high sensitivity, and delicate frictionless bearings, the Stoppani compass may be utilized to advantage as a highly precise galvanometer for detecting electric currents in experimental or conventional radio circuits. The Compass is easily and readily converted into said galvanometer by merely winding several turns of ordinary radio wire completely around the face and lower case of the compass; leaving small spaces between turns to observe the movements of the needle. The ends of the wire are brought out as test leads to be inserted in series in circuits under test. A deflection of the compass needle in either direction indicates the presence of an electric current. Incidentally the intensity of the current may be closely approximated since the force with which the needle rotates is proportional to the intensity of the current flowing through the wire. Stoppani Compass is an ideal SURVEYORS instrument with elevated sights. It is made of Solid Bronze, Parkersized, non-rusting, graduated in 1/10, Ruby Jewelled, 4 inches square. Fitted in a hardwood case, with set screw in corner to hold needle rigid when not in use. The United States Government paid more than \$30.00 for this precision instrument.

Our Price \$4.50

Gold Shield Products Company

102 Chambers Street SWC New York, N. Y.

DATAPRINTS!!

ARRIVED AT LAST!

Blueprint Construction Data for Building Apparatus that many amateurs have longed to own, but lacked the Construction Data.

- How to build 1/16 H.P. 110 volt A.C. 60 cycle motor (Suitable for Television).....\$1.00
- How to build 60 cycle Phonio Wheel..... .50
- Data for a 1,200 cycle Phonio Wheel..... .50
- Construction data for powerful battery electro-magnet..... .50
- Data for 110 volt, D.C. magnet to lift 25 pounds..... .50
- Data for 110 volt, D.C. Solenoid to lift 2 pounds through 1 inch..... .75
- Data for 110 volt, D.C. Solenoid to lift 6 pounds through 1 inch..... .75
- Data for 12 volt, D.C. Solenoid to lift 2 pounds through 1 inch..... .50
- Testa or Oudin coil data for 30-36" spark..... .75
- Testa or Oudin coil data for 6 to 8" spark..... .75
- Transformer data: 100 to 5,000 watts (1 primary and 1 secondary) (specify size and voltage desired)..... 1.00
- Home Refrigerating Machine..... 1.00
- Telegraphone (records voice on steel wire)..... .75
- 10 Short wave operating kinks..... .75
- 10 Television operating kinks..... 1.00 (Including lens disc and eraser tubes.)
- Electric chime ringer for ordinary clocks..... .75
- 20 Telephone hook-ups..... 1.00

Send Check or Money Order (cash at own risk) no stamps. Prices quoted are postpaid.

20% discount on orders for \$5.00 or more.

The DATAPRINT Company

Lock Box 322 RAMSEY, N. J.

When to Listen In

Rugby, England

Rugby, the center of the very active British G. P. O. trans-oceanic phone stations, is harboring a new experimental transmitter on 88.4 meters, or 3,396 kilocycles. The call letters are G6RX. Reading and intelligibility tests are being made almost daily. The station is reported by British listeners during the day and the evening, which means not later than 6:00 or 7:00 p.m., E.S.T. in the United States.

Moscow Stations

There appear to be two short-wave broadcasting stations in Moscow, one on 45.38 meters and the other on 50 meters, and both using the announcement, "This is Moscow calling." An English session is held on Monday, Wednesday, Friday and Sunday, beginning at 3:00 p.m., E.S.T. Most of the speeches take the form of Soviet propaganda.

Because of the time difference and the wavelengths employed, few American listeners have been able to bring in these stations. However, as we insist on repeating, "you can never tell"!

Canada

The University of Western Ontario is operating an experimental transmitter having the call letters VE9BY. The power is 20 watts. The schedule of transmission, in E.S.T., is as follows:

- Monday, 3:00 to 4:00 p.m., on 8,650 kc.
- Wednesday, 8:30 to 9:30 p.m., on 6,425 kc.
- Friday, 7:00 to 7:55 a.m., on 6,425 kc.
- Saturday, 8:00 to 11:00 p.m., on 6,425 kc., 12 Midnight, on 4,795 kc.

A Hint Regarding Verifications

If you expect to receive a letter or card of acknowledgment from foreign stations to which you have sent reports of reception, do not fail to include an international postal coupon in your outgoing envelope. DO NOT SEND AMERICAN STAMPS! This may sound like superfluous advice, but many people do it and wonder why they never hear from the DX stations concerned. A U. S. stamp is no more acceptable to the postal authorities of Australia than an Australian stamp is to our own Post Office Department. International postal coupons, which are good in practically all the civilized countries of the world, cost nine cents each and may be purchased at any post office station.

Another thing to bear in mind is that many foreign stations do not have English-speaking persons on their staffs, and therefore letters written in English (particularly in scrawly, undecipherable handwriting), receive no attention. The promptness with which some foreign stations answer letters "written in their own language" is proof that they will acknowledge reception reports sometimes. Even your crude high-school or college French, German or Spanish will bring results. Incidentally, French is the language of international intercourse, and is the most effective language to use in correspondence with the Asiatic and Central European countries. Your son's or young brother's French teacher will be glad to translate a few short letters for you.

By way of further suggestion, please keep in mind the postage rates to various countries. First-class letters at 2 cents per ounce or additional fraction thereof, and post cards at one cent, may be sent to the following countries: Argentina, Bolivia, Canary Islands, Brazil, Colombia, Chile, Cuba, Costa Rica, Dominican Republic, Ecuador, Guatamain, Haiti, Honduras, Mexico, Spanish Morocco, Nicaragua, Panama, Paraguay, Peru, Salvador, Spain and its colonies, Uruguay, and Venezuela.

Letters three cents per ounce, and cards two cents each, to Canada (watch out for this), Labrador and Newfoundland.

Letters five cents each ounce, and cards three cents each, to Great Britain, Northern Ireland and Irish Free State. These same rates apply to all other foreign countries not previously mentioned.

AERO WORLDWIDE SHORTWAVE RECEIVER

\$6.45

Listen in DIRECT to London, Paris, Berlin, Buenos Aires and other broadcast stations throughout the world via short waves. Your ordinary receiver cannot tune in these low wave stations. WORLD-WIDE RECEIVER gets 14 to 550 meters.



AERO SHORT WAVE CONVERTERS

Convert Your Present Set Into a Short Wave Super-Heterodyne

- A. C. MODEL \$12.50—D. C. MODEL \$11.50
- At Last! The Perfect Auto Radio, Only \$20.00

Built by pioneers in the manufacturing of Auto Radio.



We guarantee 1000 miles radius of reception. A masterpiece of Radio Engineering. Latest model 6 Tube Aero Pentode Auto Radio. Price of set only \$20.00. Set complete with tubes, batteries, dynamic speaker, antenna equipment and noise suppressors, \$39.50. Send for Complete Catalog.

CHAS. HOODWIN CO. 4240 LINCOLN AVENUE Dept. O-17, Chicago, Ill.

MIDGET MICROPHONES



SINGLE

- No. 1..... \$5.00
- No. 2..... 7.50

TWO-BUTTON

- No. 3..... \$10.00
- No. 4..... 15.00

MILES REPRODUCER CO.
26 East 22nd Street
Dept. SW1 New York

"HAM" ADS

Advertisements in this section are inserted at 4c per word to strictly amateurs or 8c a word (8 words to the line) to manufacturers or dealers for each insertion. Name, initial and address each count as one word. Cash should accompany all "Ham" advertisements. No less than 10 words are accepted. Advertising for the June issue should reach us not later than April 10.

PUSH-PULL TNT 245 TRANSMITTER, aluminum panel, millimeter, forty and eighty meter copper tubing coils, neat and efficient, \$14.75. Eighty meter portable transmitter, case, aluminum panel, millimeter, cable and plug to obtain power from broadcast receiver, power pack, or batteries, \$11.75. All inquiries answered, or will send photo and blueprint of either transmitter for 25 cents. W7SZ, E618 Wabash Ave., Spokane, Wash.

WILL TRADE PACENT PICKUP and Bodine Induction Motor with turntable and Sonatron 3 stage resistance-coupled unit for a good A.C. short wave super het. Write Edwin Julian, Cherry, Ill.

PILOT A.C. SUPER-WASP tuned screen grid short wave and broadcast bands. Including all coils, B and filament supply, speaker and tubes. In perfect condition, \$24. Sell without speaker or B supply if wanted. F. Forster, 676 Pelham Rd., New Rochelle, New York.

PHILCO "95" nine tube set with tubes and speaker, \$32.00. J. Turk, 4902 Elkins Ave., Nashville, Tenn.

SET OF FIVE copper tubing plate and antenna coils for push-pull transmitter, \$3.25 postpaid. W7SZ, E618 Wabash Ave., Spokane, Wash.

S-W Calls in Venezuela

Caracas, Venezuela.

Editor SHORT WAVE CRAFT:

I am a reader of your wonderful magazine, SHORT WAVE CRAFT, and I get my copies from your agent in this country. I am sending you the official list of our short wave stations, obtained from the Department of Communications in Caracas, and I hope to see them in the next issue of your Magazine.

Call	City	Meters	Kc.
YV7BC	Caracas	48.80	6150
YV2BC	Caracas	49.58	6050
YV3BC	Caracas (day)	25.20	11900
YV3BC	Caracas (night)	31.60	9590
YV1AC	Caracas	75.	4000
YV8BC	Caracas	31.40	9540
YV5BC	Caracas	31.20	9600
YV9BC	Caracas	48.80	6150
YV10BC	Caracas	25.48	11780
YV14BC	Caracas	49.20	6097
YV4BV	Valencia	25.80	11700
YV12BM	Maracay	49.40	6100
YV6BM	Maracay	31.55	9510
YV11BMO	Maratenibo	48.95	6128
YV13BOL	Cd. Bolivar	31.50	9523

All of these stations work daily at different hours so it is not necessary to send the time schedule.

I remain,

Very truly yours,

LOUIS A. UZCATEGUI.

Address: Sur 12 No. 34-13,
Caracas, Venezuela.—S. A.

Clarostat Control Hand Book and Catalog, 1932

A very valuable compendium of radio control data is incorporated in this latest Clarostat information manual and catalog. It contains a wealth of technical information for all radio constructors and students, that one can hardly afford to be without.

Among some of the interesting control apparatus described both from the catalog as well as the manual point of view are:—Volume controls, attenuators, constant impedance controls, variable resistors for tone control and other resistors which every radio constructor has a use for constantly. The pages of this handsome combination manual and catalog are printed on a fine quality paper, measuring 8½ by 11 inches.

Among some of the valuable technical data given in the information section are: The Meaning of Tapers in Control Units; How to Select Suitable Volume Controls; Volume Controls in R.F. Circuits, With Diagrams (diagrams illustrate all of these subjects); Antenna Circuit Volume Controls, Screen Grid Volume Control Circuits, Combination Grid Bias and Antenna Stage Volume Controls, Television Motor Speed and Neon Tube Controls, Automatic Voltage Regulators. You may obtain one of these valuable manuals by writing to the Clarostat Mfg. Co., 285-287 No. Sixth St., Brooklyn, N. Y., and mentioning this publication.

Aerovox 1932 Condenser and Resistor Manual and Catalog

A technically valuable desk and workshop companion indeed is this new combination manual and catalog for 1932 being distributed by the Aerovox Wireless Corp., 70-82 Washington St., Brooklyn, N. Y.

Every radio amateur, service man, and set constructor needs this manual as a ready reference. The reviewer confessed he did not know there were so many different styles of condensers and resistors manufactured under one roof, as is disclosed by a perusal of this highly informative and really valuable manual and catalog of the Aerovox products. Among some of the interesting condensers we find electrolytic types scheduled in various "capacity groupings", all the way from one up to 4,000-mf. capacity. Every imaginable type and combination of condenser groups for filters are to be found.

Eastern Amateur Radio League

President—Thornton W. Dawson, W2CYR
Financial Sec'y—Robert McCourt
Corresponding Sec'y—Albert Ryberg
Advisory Director—C. Robert Seybolt
Organized Dec. 10, 1931. Present membership 20 members, of which there are 5 operators. Will begin operating on 80 meters, Phone and CW about April 15th. Amateurs under 25 years of age welcome to membership.

**SEND 15c
FOR SAMPLE
COPY
(See Coupon)**

**The
Television
Trend...**

Timely developments in radio's latest wonder, Television, are published in every issue of TELEVISION NEWS—Mr. Hugo Gernsback's latest magazine. Rapid advancement in this art today is becoming a repetition of the radio cycle of years ago. Daily broadcasts are becoming more numerous and experimenters are following in quick order in building television sets for experimental purposes. Foresight of its development can be seen by the pioneers of radio—they are equipping themselves now with television experience.

The articles published in TELEVISION NEWS are of primary importance to experimenters—they are simple in construction, understandable and replete with diagrams, photographs and illustrations.



A Few of the Interesting Articles

- Latest Developments in Cathode Ray Television
- Television is Coming but Who Will Pay the Bill?
- How to Make a Practical Television Receiver
- A 7-10 Super Regenerative Television Receiver
- Better Optics for Lens Discs
- Crystal Detectors for Television
- Scanning Frequencies for Cathode Ray Tubes
- Constructing Your Own Lens Disc
- Color Television
- Television Course

Television News,
98 Park Place, New York, N. Y.

SWC 3-1

Mark X in square which offer desired:

- As per your Special Offer, I enclose \$1.25 (Canada and Foreign \$1.50), for which enter my subscription to TELEVISION NEWS for one year.
- Send me a sample copy of TELEVISION NEWS for which I enclose 15c (U. S. Stamps or coin accepted).

Name

Address

City..... State.....





J. E. Smith, President, National Radio Institute, the man who has directed the Home-Study training of more men for the Radio Industry than any other man in America.

BE A RADIO EXPERT

Many Make \$50 to \$100 a Week

I'll Train You at Home in Your Spare Time for RADIO-TELEVISION-TALKING MOVIES



Set Servicing

Spare-time set servicing pays many N. R. I. men \$200 to \$1,000 a year. Full-time men make as much as \$65, \$75 and \$100 a week.



Broadcasting Stations

Employ trained men continually for jobs paying up to \$5,000 a year.



Ship Operating

Radio operators on ships see the world free and get good pay plus expenses.

Aircraft Radio

Aviation is needing more and more trained Radio men. Operators employed through Civil Service Commission earn \$1,620 to \$2,800 a year.



Talking Movies

An invention made possible by Radio. Offers many fine jobs to well-trained Radio men, paying as much as \$75 to \$200 a week.



Television

The coming field of many great opportunities is covered by my course.



IF you are dissatisfied with your present job, if you are struggling along in a rut with little or no prospects of anything better than a skinny pay envelope—clip the coupon NOW. Get my big FREE book on the opportunities in Radio. Read how quickly you can learn at home in your spare time to be a Radio Expert—what good jobs my graduates have been getting—real jobs with real futures.

Many Radio Experts Make \$50 to \$100 a Week

In about ten years the Radio Industry has grown from \$2,000,000 to hundreds of millions of dollars. Over 300,000 jobs have been created by this growth, and thousands more will be created by its continued development. Many men and young men with the right training—the kind of training I give you in the N. R. I. course—have stepped into Radio at two and three times their former salaries.

Get Ready Now for Jobs Like These

Broadcasting stations use engineers, operators, station managers, and pay up to \$5,000 a year. Manufacturers continually employ testers, inspectors, foremen, engineers, service men, buyers, for jobs paying up to \$6,000 a year. Radio Operators on ships enjoy life, see the world, with board and lodging free, and get good pay besides. Dealers and jobbers employ service men, salesmen, buyers, managers, and pay up to \$100 a week. My book tells about these and many other kinds of interesting radio jobs.

Many N. R. I. Men Have Made \$200 to \$1,000 in Spare Time While Learning

The day you enroll with me I send you material which you should master quickly for doing 28 jobs, common in

most every neighborhood, for spare time money. Throughout your course I send you information on servicing popular makes of sets; I give you the plans and ideas that have made \$200 to \$1,000 for N. R. I. students in their spare time while studying. My course is famous as the course that pays for itself.

Talking Movies, Television, Aircraft Radio Included

Special training in Talking Movies, Television and home Television experiments, Radio's use in Aviation, Servicing and Merchandising Sets, Broadcasting, Commercial and Ship Stations are included. I am so sure that N. R. I. can train you satisfactorily that I will agree in writing to refund every penny of your tuition if you are not satisfied with my Lessons and Instruction Service upon completion.

64-Page Book of Information FREE!

Get your copy today. It tells you where Radio's good jobs are, what they pay, tells you about my course, what others who have taken it are doing and making. Find out what Radio offers you without the slightest obligation. ACT NOW!

J. E. SMITH, President
National Radio Institute
Dept. 2EB3
Washington, D. C.



THIS COUPON IS GOOD for
One FREE COPY OF MY BOOK *mail it now*

J. E. SMITH, President
National Radio Institute, Dept. 2EB3
Washington, D. C.

Dear Mr. Smith:
I want to take advantage of your Special offer. Send me your two books, "Trouble Shooting in D. C., A. C. and Battery Sets" and "Rich Rewards in Radio." I understand this does not obligate me and that no salesman will call.

Name.....
Address.....
City.....State.....

Special Free Offer



Act now and receive in addition to my big free book, "Rich Rewards in Radio," this Service Manual on D.C., A.C., and battery operated sets. Only my students could have this book in the past. Now readers of this magazine who mail the coupon will receive it free. Overcoming hum, noises of all kinds, fading signals, broad tuning, howls and oscillations, poor distance reception, distorted or muffled signals, poor Audio and Radio Frequency amplification and other vital service information is contained in it. Get a free copy by mailing the coupon below. ACT NOW.

SM

**FROM THE OTHER SIDE
OF THE WORLD—**

**A 727SW WILL KEEP YOU
IN TOUCH WITH YOUR HOME**

**SHORT - WAVE
LONG-WAVE
ONE DIAL
ONE CHASSIS**



COLOR TUNING—calibrates each short-wave band on the dial with the same accuracy as the broadcast band. You will find it **ONLY** in the Silver-Marshall 727SW. It makes finding foreign stations easy.

**ONE DIAL—CALIBRATED
NEW PATENTABLE CIRCUIT
AUTOMATIC VOLUME CONTROL
METER-TUNING
FRACTIONAL
MICROVOLT SENSITIVITY
ABSOLUTE 10KC SELECTIVITY
PENTODE-VARIO-MU TUBES**

SILVER-MARSHALL, Inc.

6457 W. 65th St.

CHICAGO, U. S. A.

**SILVER-MARSHALL, Inc.
6457 W. 65th St.
Chicago, U. S. A.**

Enclosed find 2c. Please send all the 727SW details.

Name

Address

Super Power

insures

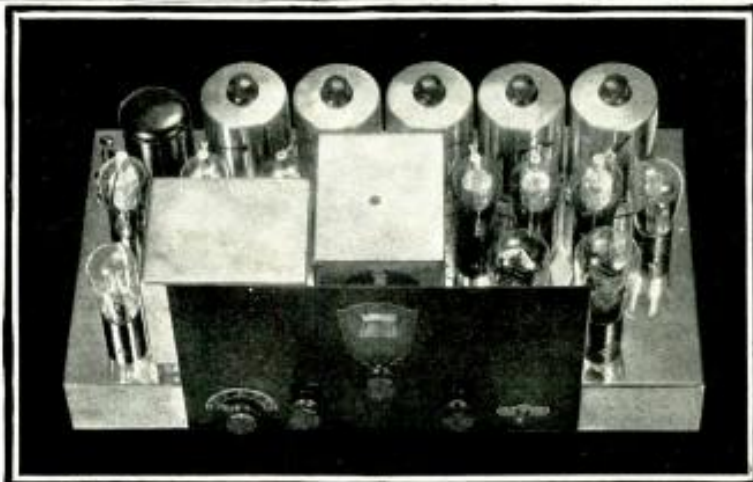

World-Wide Performance- 15 TO 550 METERS-NO PLUG-IN COILS

Lincoln Super powered receivers are bringing in the finest reports we ever received. New short-wave stations coming on the air are reported to us from the Pacific Coast to New York City.

From California comes the following report: "I have picked up many SW stations. Sidney, Rio de Janeiro, Indo-China, Rome, Russia, Australia, Manila, Saigon, Mexico, Hawaii, Fiji Islands, and Siam. This is only a small list of stations picked up on the Lincoln. We tried out five other well known makes of widely advertised AC all-wave receivers, but found the Lincoln in a class by itself."

Selectivity

Many fine reports of extreme selectivity reflect the precision engineering of Lincoln equipment. A recent report from Staten Island, New York states: "Received WLW 700 K.C. WOR 710 K.C. WGN 720 K.C. CMK Cuba 725 K.C. Canadian 730 K.C. XER 735 K.C. WSB 740 K.C." Note the 5 K.C. separation of powerful stations.

A New Conception of Short-Wave Reception

The application of Lincoln's mighty power to the reception of short-waves produces truly amazing results. Stations half-way around the world come in with clock like regularity. Lincoln enthusiasts in the central states have repeatedly reported *broadcast* reception of

many trans-Pacific stations. The tremendous amplification of the highly engineered Lincoln circuit is always perfectly controlled in a channel less than 10 K.C. wide. A letter from Alaska reports reception of Mexico, Nebraska and Vancouver, B. C., all three stations 5 K.C. apart!

Full, Rich, Life-Like Lincoln Tone

Lincoln tone is a revelation of purity and fidelity. Lincoln experts have designed an audio system that, with either radio or phonograph pick-up input, delivers tone of astonishing richness and realism. Artificial tone compensators or control devices are not required to bring out the natural vivid tone of the living artist.

DeLuxe DC-SW-10, Battery Model, Is Extremely Efficient

The Lincoln DeLuxe DC-SW-10 is the battery model version of the famous DeLuxe SW-32 described above. Taking advantage of the new low drain 2 volt tubes, the DC-SW-10, when operated from an adequate battery source, provides exceptionally quiet, crystal clear reception of both broadcast and short-waves. This model, although intended for rural or un electrified areas, is finding increasing favor in congested city communities because of its absolute freedom from line noise and clear life-like tone quality.

Clip and Mail NOW!

**LINCOLN
DE LUXE-SW-32**

LINCOLN RADIO CORPORATION

Dept. SWC-7, 329 S. Wood St., CHICAGO, ILL.

Please send descriptive literature to NAME.....

ADDRESS.....

CITY.....

STATE.....